

SECTION AA

page 10

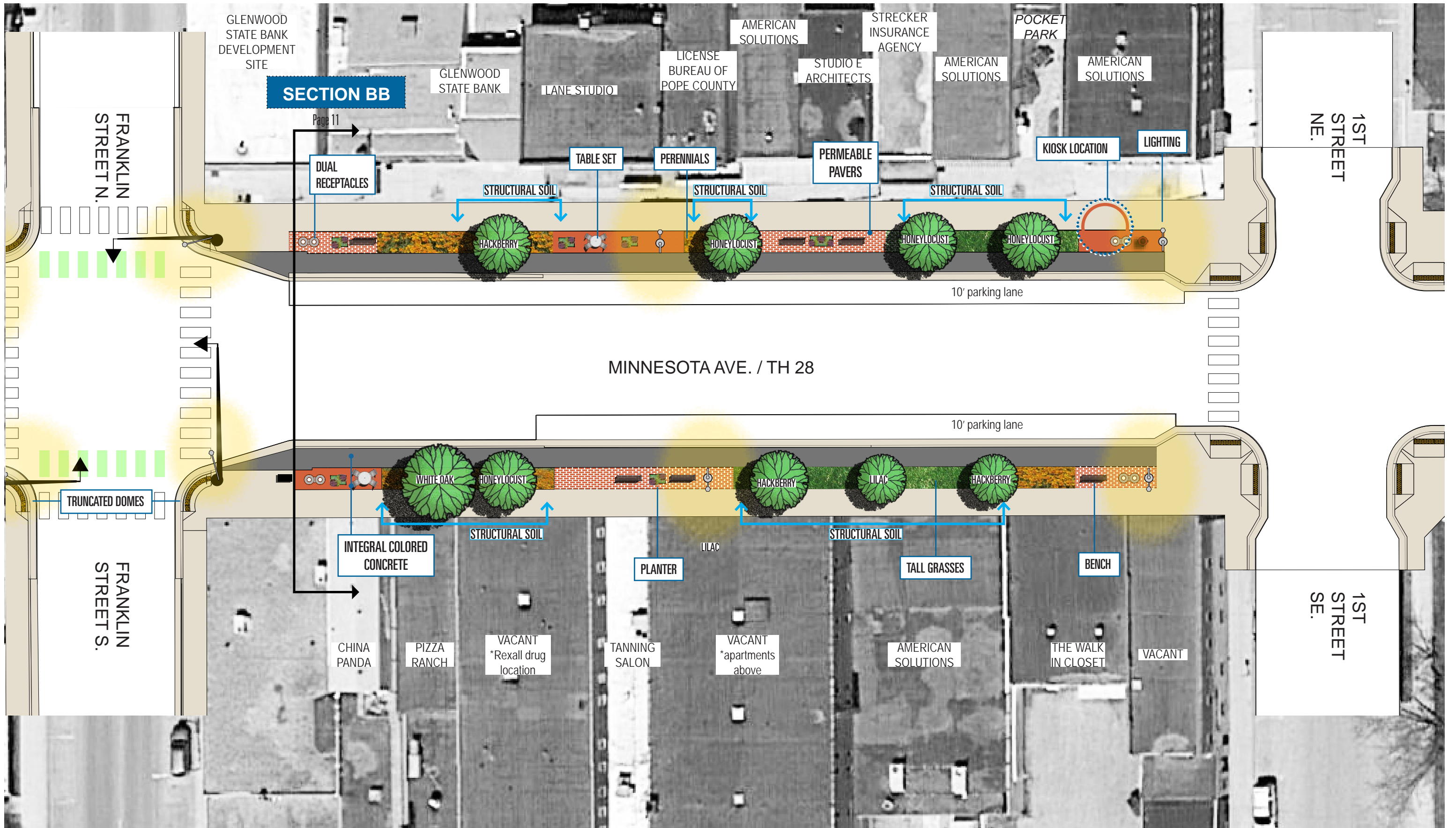

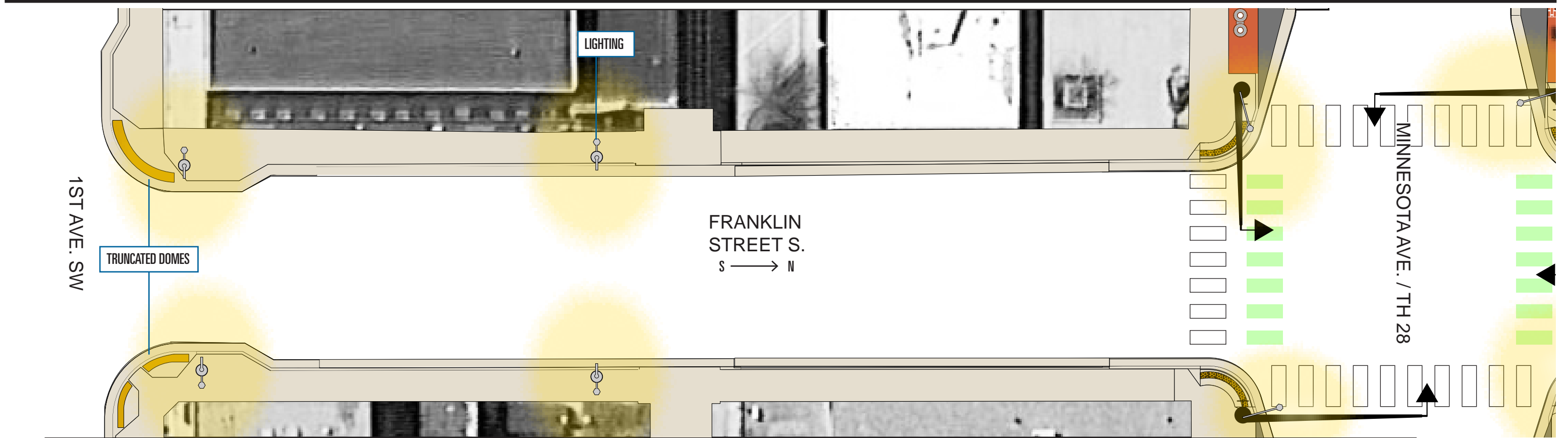

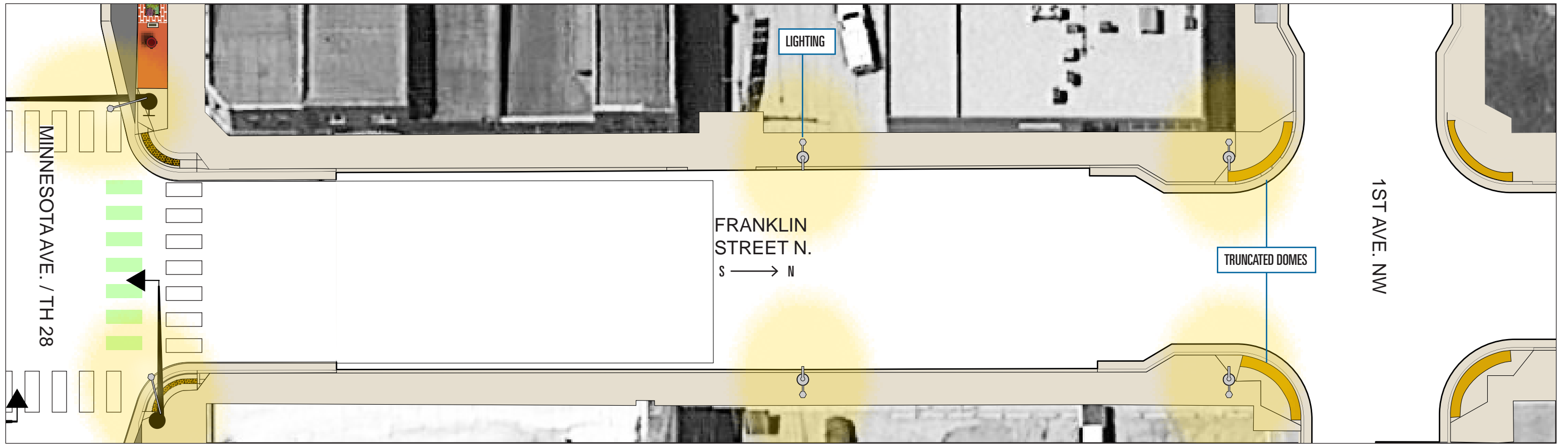

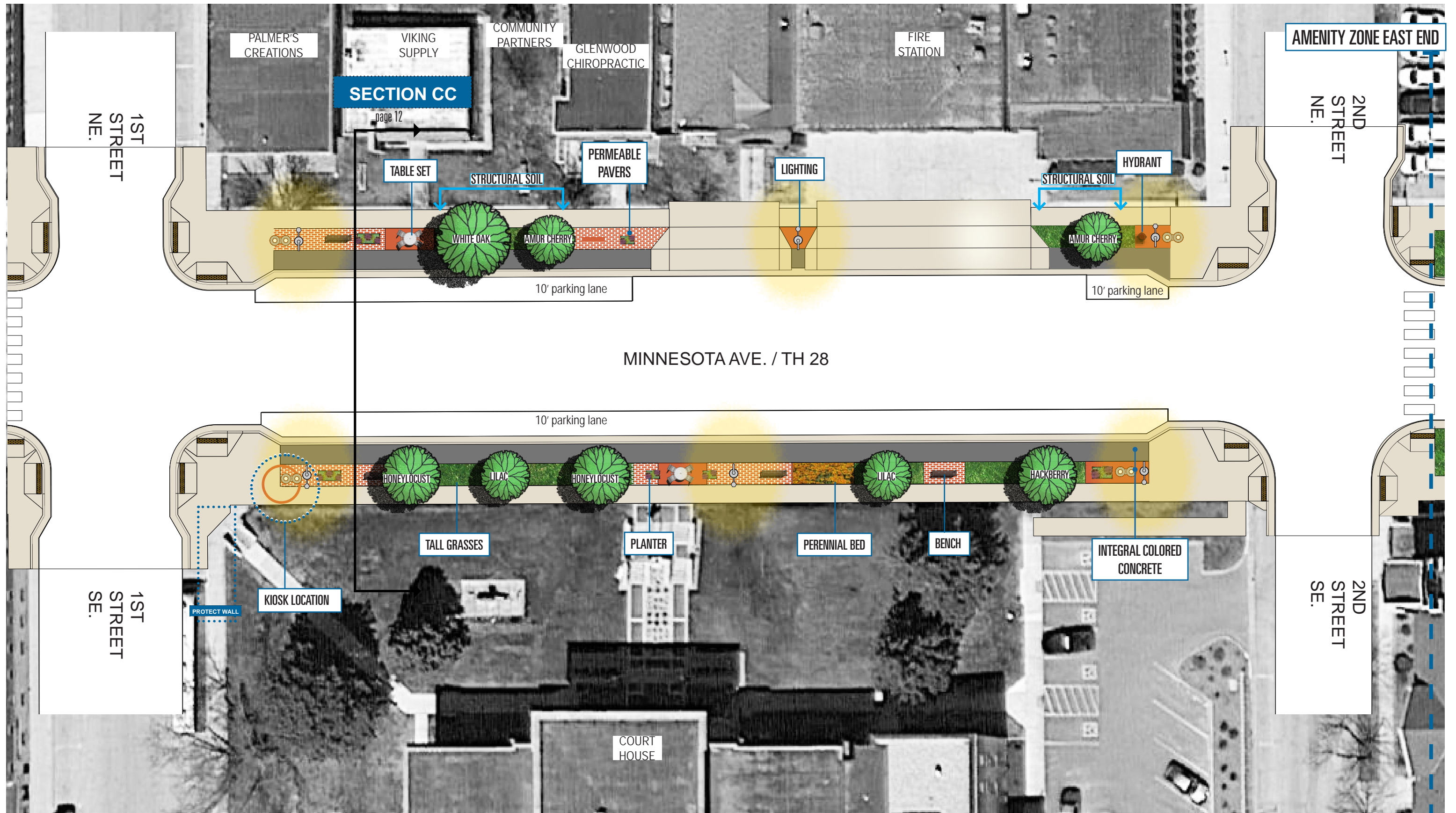

PRECEDENT IMAGERY

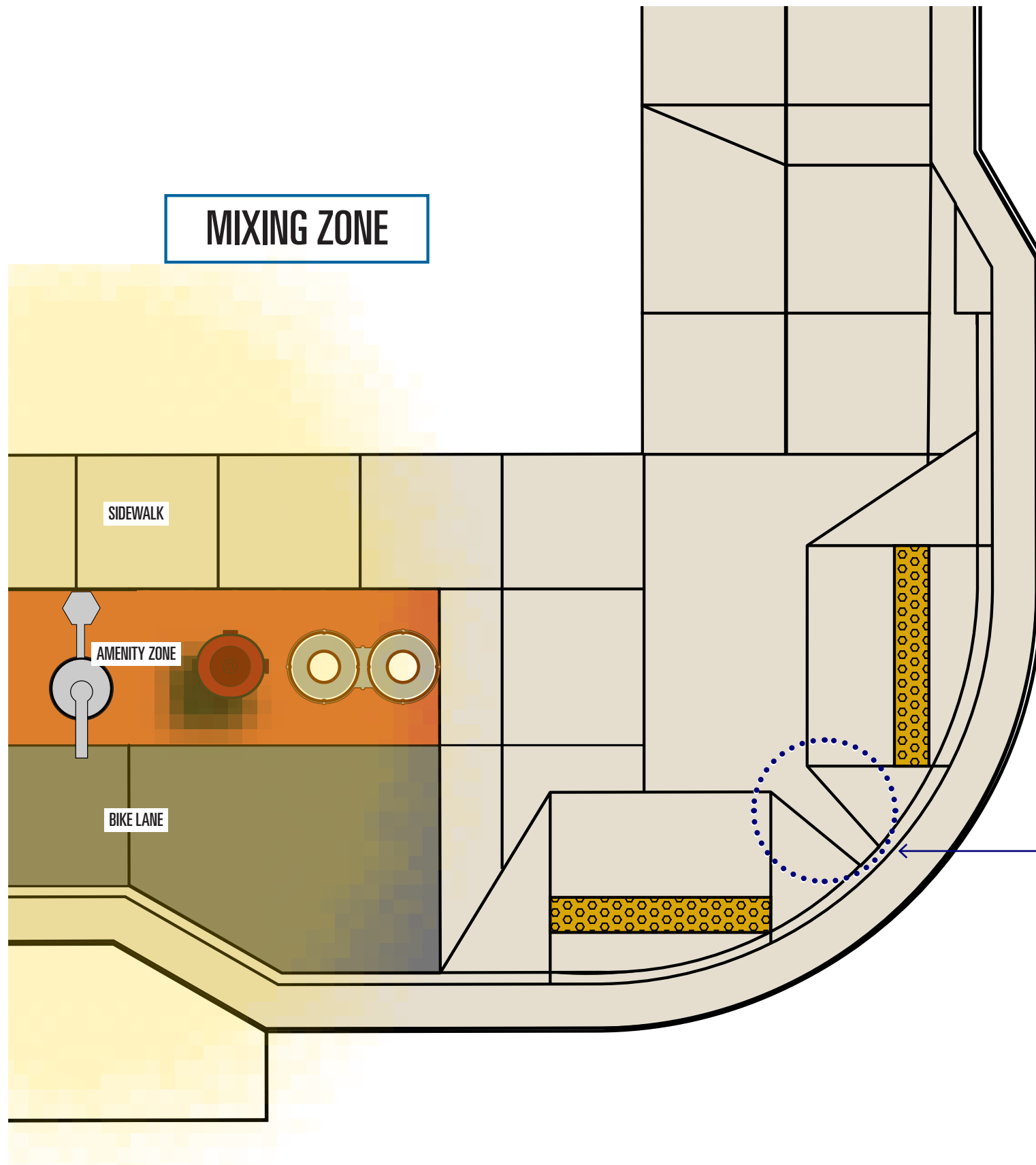

SAW CUT JOINTS INTEGRAL COLORED CONCRETE

- No shale mix
- Select granite mix
- Issues with iron discoloration
- Mndot certified / approved mix
- Concrete jointing to be refined during final design

BRUSHED FINISHED COLOR SELECTIONS:

- Sidewalk - standard concrete coloration spec by Mndot.
- Amenity Zone - Solomon Inc. Color: "TRAIL DUST"
- ***Permeable pavers to match coloration at lake walk***
- Bike Lane - Solomon Inc. Color: "ONYX"



→ MATCH ELEVATED "FIN" TO CURB



SALT TOLERANT, COLD TOLERANT, LOW MAINTENANCE PLANTS

Planting zones create a sense of visual and environmental relief.
 Prairie plantings, wild flowers, pollinators and ornamental can be used here to:
 HIGHLIGHT BUSINESSES.
 CREATE SEATING AREAS.
 ACCOMMODATE NECESSARY ECOSYSTEM SERVICES.

Trees:

- Amur Cherry - *Prunus Maackii*. 20' h
- Japanese Tree Lilac - *Syringa reticulata*. 25' h
- Honeylocust - *Gleditsia triacanthos var. inermis*. 35' h
- Columnar White Oak - *Quercus alba*. 40' h
- Hackberry - *Celtis Occidentalis*. 50' h



CHERRY



LILAC



HONEYLOCUST



OAK



HACKBERRY

Shrubs:

- Dogwood - *Cornus stolonifera* 'arctic fire'. 4'w, 4'h
- Rock Cotoneaster - *Cotoneaster horizontalis var. perspusillus*. 5'w, 2'h
- Fragrant Sumac - *Rhus aromatica 'gro-low'*. 6'w, 2'h
- Burgundy Candy Ninebark - *Physocarpus opulifolius 'Podaras'*. 30" w, 3' h
- Winterberry - *Ilex verticillata 'red sprite'*. 4'w, 2'h
- Cinquefoil - *Potentilla fruticosa 'fargo'*. 4'w, 3'h



DOGWOOD



COTONEASTER



FRAGRANT SUMAC



NINEBARK



WINTERBERRY

Tall Grasses:

- Little Bluestem - *Schizachyrium scoparium* 'standing ovation'. 12" w, 4' h
- Prairie Dropseed - *Sporobolus heterolepis*. 3' h
- Cord Grass - *Spartina pectinata var. Aureomarginata*. 3-5' h
- Feather Reed Grass - *Calamagrostis x. acutiflora*.
- Purple Millet - *Pennisetum glaucum*



BLUESTEM



DROPSEED



CORD



REED



MILLET

Perennials:

- Catmint - *Nepeta spp.* Ground cover, 30" h
- Russian Sage - *Perovskia atriplicifolia*
- Purple Coneflower - *Echinacea Purpurea*. 2'w, 4'h
- Orange Stonecrop Sedum - *Sedum kamtschaticum var. ellacombeanum*. 2'w, 6" h
- Vera Jamison - *Hylotelephium 'Vera Jamison'*. 1'w, 1'h
- Blazing Star. *Liatris spicata 'Kobold'*. 16" w, 18" h
- Variiegated Sweet Iris. *Iris pallida 'variegata'*. 18" w, 24" h
- Black Eyed Susan. *Rudbeckia fulgida*. 24" w, 24" h



CATMINT



SAGE



CONE FLOWER



SEDUM



VERA JAMISON



BLAZING STAR



IRIS

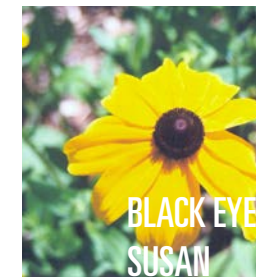

BLACK EYED SUSAN

PLANTING BEDS BY HEIGHT

8"-12" PLANTS INCLUDE

- Vera Jameson Sedum
- Little Blue Stem

8-12"

12" - 24" PLANTS INCLUDE

- Purple Coneflower
- Blazing Star Liatris
- Variegated Sweet Iris
- Stonecrop Sedum
- Winterberry
- Fragrant Sumac
- Coneaster

12-24"

24" - 4' PLANTS INCLUDE

- Black Eyed Susan
- Russian Sage
- Catmint
- Ninebark
- Cinquefoil
- Prairie Dropseed
- Purple Millet Grass

24" - 4'

4' + PLANTS INCLUDE

- Dogwood
- Cord Grass
- Feather Reed Grass

4+'

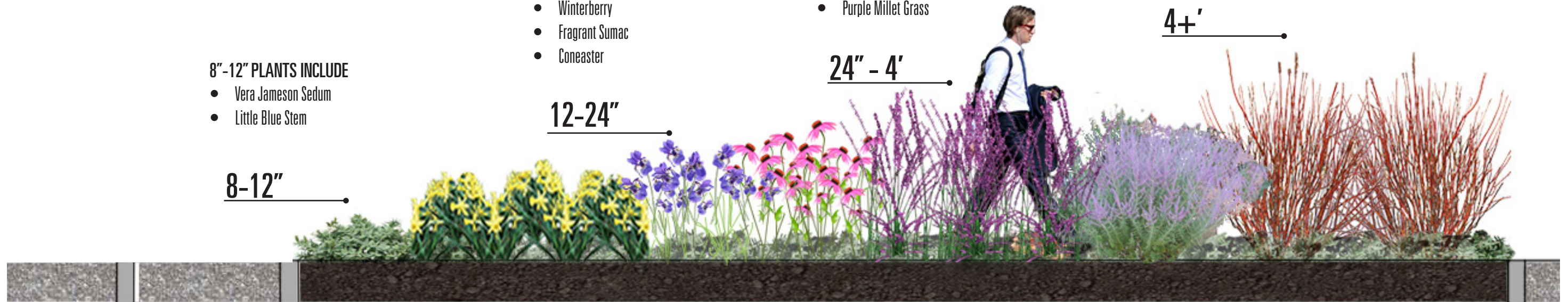

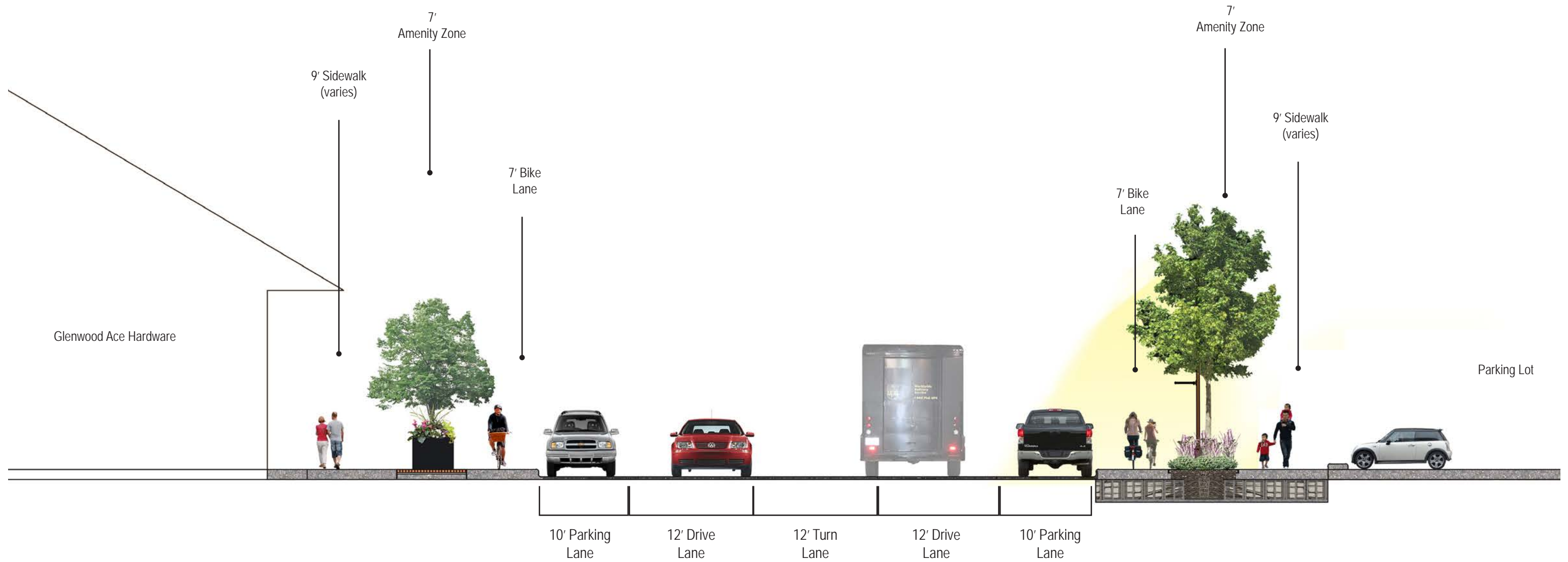

- IDEAL LOCATION FOR MIXING SMALL TO MEDIUM JAPANESE LILAC AND AMUR CHERRY TREES IN WITH STRUCUTRAL SOIL
- 30' LIGHTING UNITS WITH MNDOT APPROVED OVERHEAD GULL WING LIGHT
- LOLL PLANTER BOXES, SEATING, AND RECEPTACLES IN AMENITY ZONE

- PERENNIAL PLANTING BEDS PLANTED AND WATERED AS NEEDED.
- TALL GRASS BEDS SEEDED AND MAINTAINED AS NEEDED.

SECTION AA

SHOWN ON PAGE 3

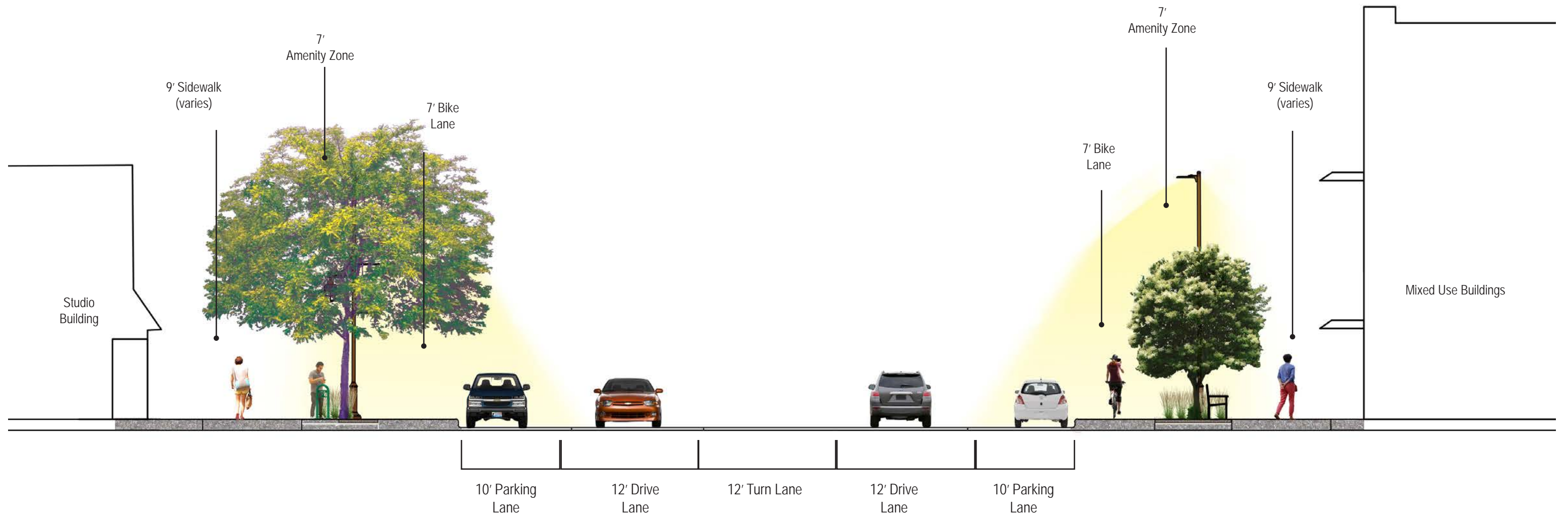

- LARGE HONEYLOCUST TREE
- PERMEABLE PAVERS, 30' LIGHTING, AND BIKE PARKING IN FRONT OF OFFICE AND COMMERCIAL SPACES

- SMALL AMUR CHERRY TREE
- BENCH SEATING AND TALL GRASS PLANTINGS FACING COMMERCIAL RETAIL AND 1-2 STORY BUILDINGS

SECTION BB

SHOWN ON PAGE 4

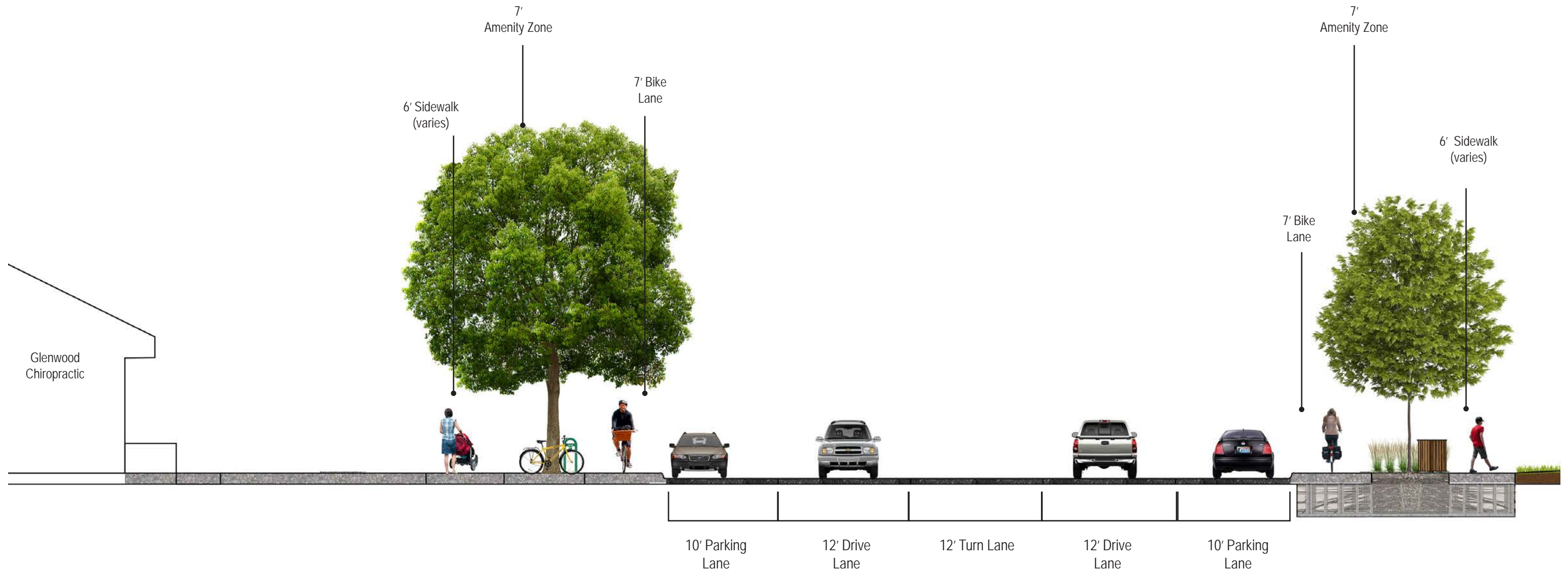

- LARGE HACKBERRY TREE
- PERMEABLE PAVERS, SEATING OPTIONS, AND BIKE PARKING

- SMALL TREE ROW OF AMUR CHERRY AND LILACS
- SOIL VAULTING FOR PLANTING BED

SECTION CC

SHOWN ON PAGE 6



TABLE SET

ANOVA FURNISHINGS

46" COSMOPOLITAN TABLE WITH 4 CONTOUR SEATS: \$2195

ITEM # L1740

Material

The table has a 46.25" diameter table top and features four contour seats and two wheelchair accessible positions that are federally ADA-compliant when table is surface mounted. The solid surface top is 12-gauge steel and features a durable 1.5" square steel yube edge. The top also featured a 1.64" diameter umbrella hole in the center and is designed to support 100lbs. per square foot. The seats are 12-gauge steel with a reinforced frame connection and feature a uniformly spaced Moroccan perforated pattern. The seats are designed to support 200 lbs. per linear foot. The table frame and legs are made of 2.38" O.D. steel tubing and designed to be portable for flexibility in placement; legs feature feet with predrilled .5" holes for surface mounting to prevent movement. Mounting hardware is not included.

Finish

Solid surface steel tubing table top and steel seats are protected by the patented FusionAdvantave finish. The plastisol coating has an average thickness of .125" and is encapsulated with a richly tinted, high performance powder coating that wont rust, fade, peel, chip, crack, mold, or mildew. The finish has been tested to the requirements of the ASTM E1354 and deterened to be in compliance with California Uniform Fire Code 1103.2.1.4.2. Fade-resistant, powder coated steel frame and legs feature a state-of-the-art primer proven to prevent rusting. Treated components exceed the industry standard by 34% in testing by independent sources.

Assembly

The table requires some assembly. The table top and seats ship pre-assembled. Stainless steel assembly hardware is included.

Maintenance

The product is virtually maintenance-free and requires only periodic cleaning with a sponge and a solution of mild detergent and water to remove surface dirt. Do no clean with solvent or petroleum base products.

Warranty

20-year limited structural warranty on recycled plastic from the date of purchase. See full details on multi-year warranties for components at www.anovafurnishings.com/warranty.aspx

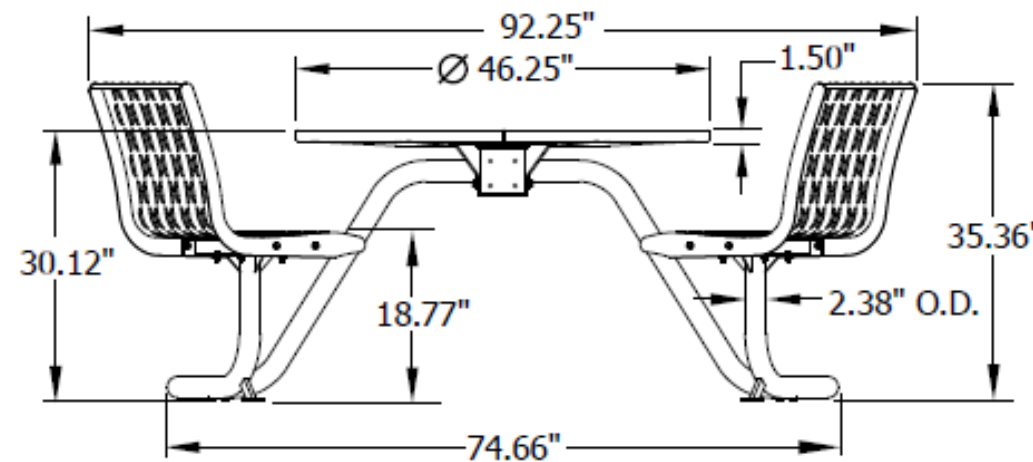
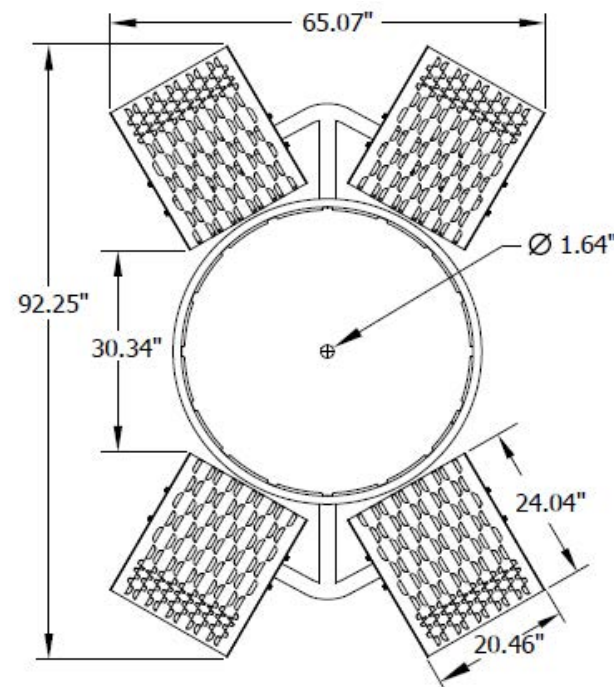

BENCH

KEYSTONE RIDGE USA

8' WITH BACK : \$1,540.00

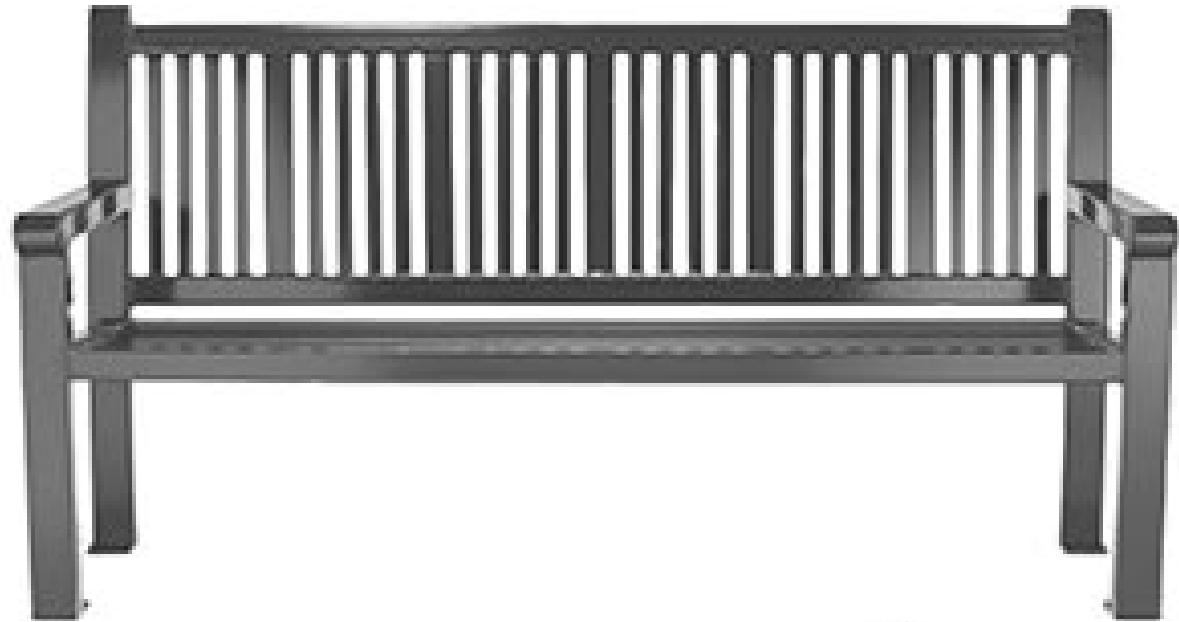

READING BENCH WITH BACK

The Reading bench with back is covered by patent no. des. 376,270. All other Reading pieces are Exclusive By Design™.

KEYSHIELD® METAL FINISH

The trademarked KEYSHIELD® finish protects each piece of furniture from chipping, cracking, and UVA damage while providing unparalleled corrosion resistance. Steel products are finished with a two-coat powder coating process applied to a 7-15 mil thickness. Substrate preparation includes sandblasting to a white finish to remove all surface contaminants. The raw product then receives a corrosion-inhibiting phosphate coating prior to the application of the powder coating. The first coat applied to the substrate is zinc rich epoxy powder primer used exclusively on sandblasted parts. The second coat is a colored polyester powder coating. Both coats are electrostatically applied and oven cured according to powder coating manufacturing specifications to create a smooth, satin-like finish and a low-emitting non-porous armor.

FULLY ASSEMBLED UNIT

The Reading bench with back is manufactured in the USA as a fully assembled unit to provide ultimate stability and avoid damage during transit to the site, saving time and money.

MATERIALS

Commercial-grade materials, at least 25% recycled raw steel, 100% recyclable steel; completely welded for optimum strength and stability according to Keystone Ridge Designs, Inc. CAD drawing; alternating back pattern of vertical 1/4" x 1" and 1/4" x 2" steel straps evenly spaced attached to 1/8" x 1" x 2" rectangular steel tubing center back frame; 1/8" x 1" x 2" rectangular steel tubing and 1/8" x 2" square steel tubing steel seat; mounted on 1/8" x 2" x 3" rectangular steel tubing legs and finished with 2" and 2-1/2" O.D. sold half round steel for decorative arm knobs.

	RE24	RE25	RE26	RE28
	4ft	5ft	6ft	8ft
LENGTH (A)	48"	59"	70"	92"
WIDTH (B)	23 7/8"	23 7/8"	23 7/8"	23 7/8"
HEIGHT (C)	37 1/4"	37 1/4"	37 1/4"	37 1/4"
SEAT HEIGHT	17"	17"	17"	17"
WEIGHT	215 lbs.	235 lbs.	251 lbs.	305 lbs.

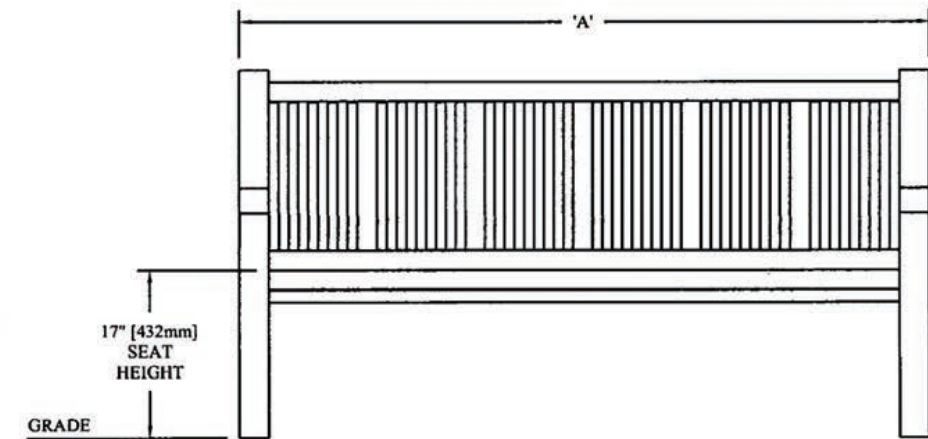
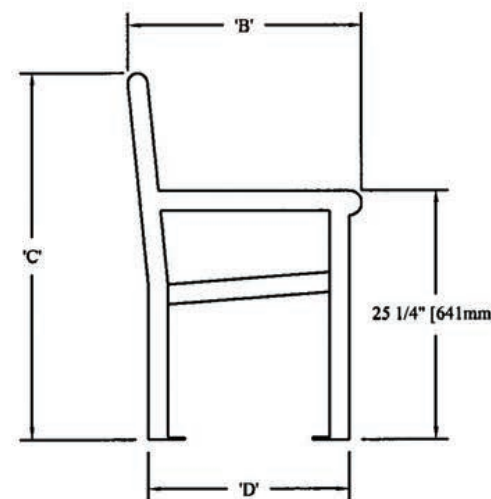
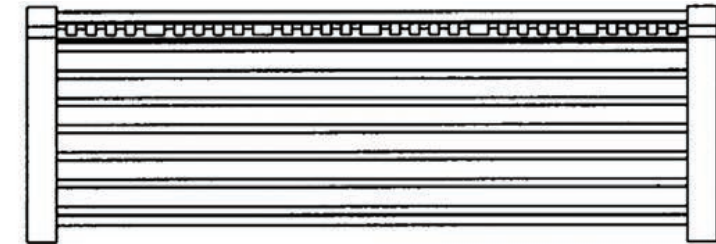

**PLANTING
CONTAINERS**

LOLL DESIGNS

28 GALLON MONDO DOUBLE PLANTER : \$320.00



100% recycled high-density polyethylene (HDPE) primarily from milk jugs (#2 plastics)

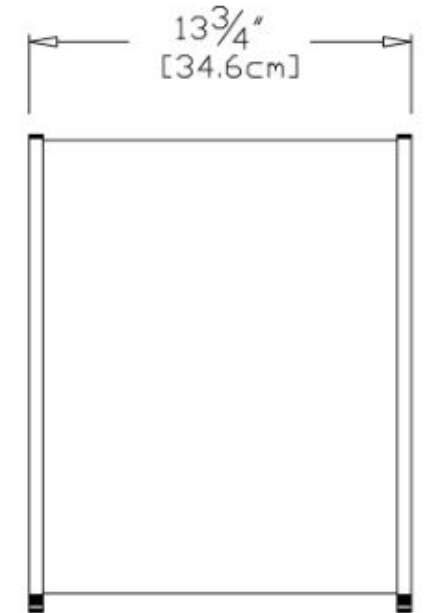
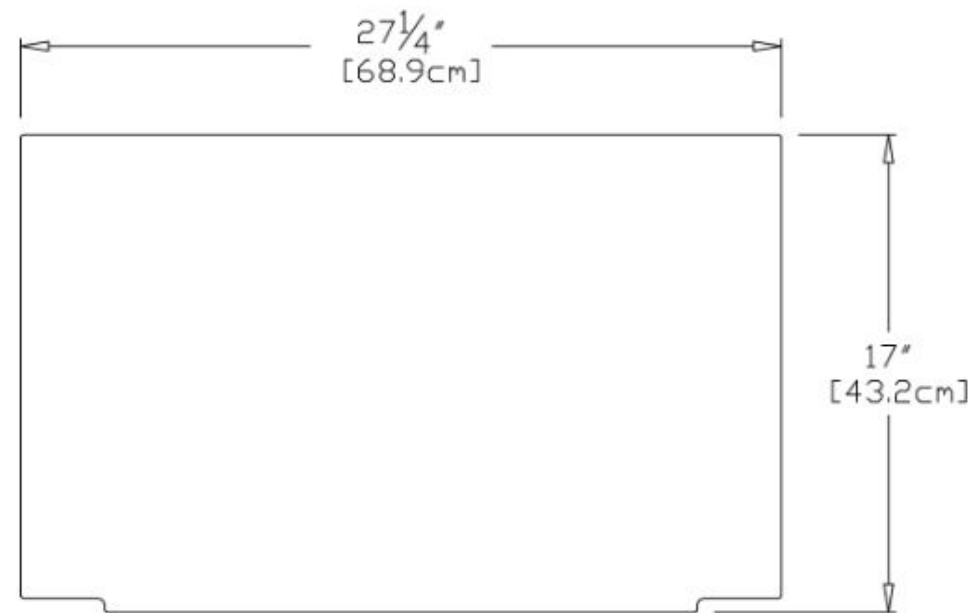

PLANTING CONTAINERS

LOLL DESIGNS



50 GALLON MONDO QUAD PLANTER : \$716.00

100% recycled high-density polyethylene (HDPE) primarily from milk jugs (#2 plastics)



DUAL RECEPTACLE

KEYSTONE RIDGE USA

32 GALLON, PENN DUAL RECEPTACLE : \$1,405.00

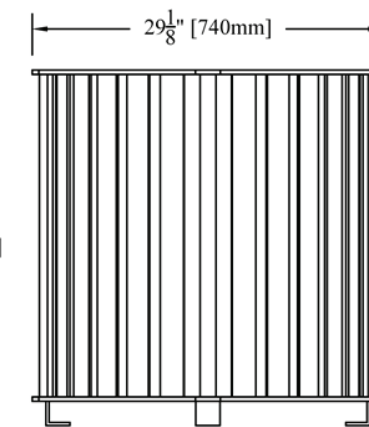
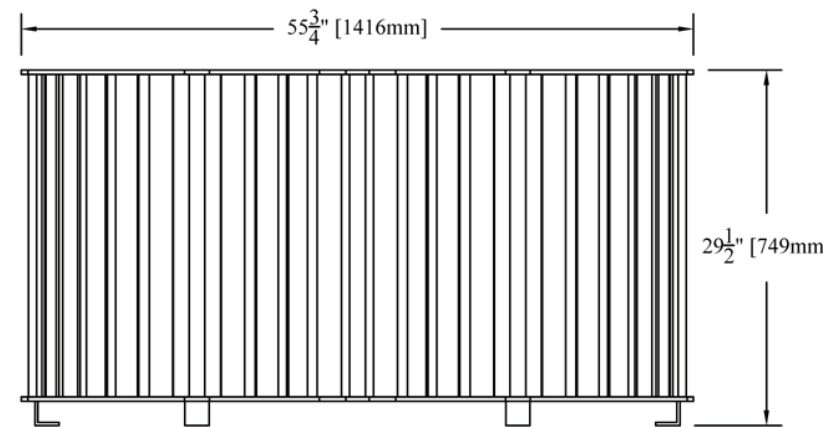
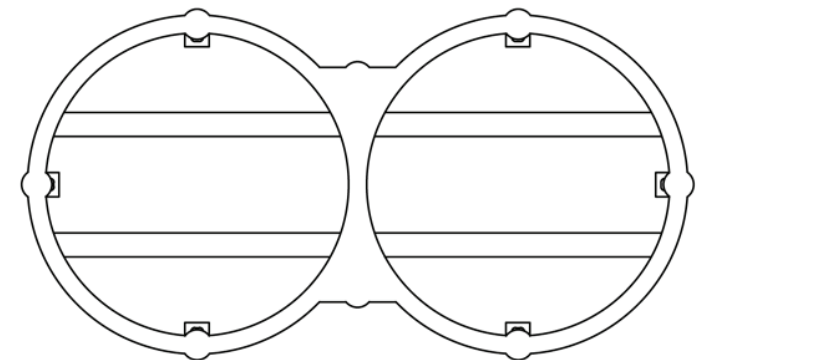
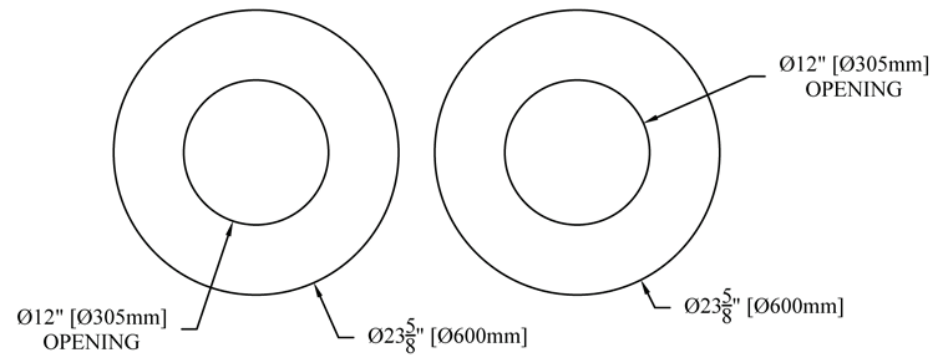

	PN3-32DRT
	32 gal.
LENGTH	55 3/4"
WIDTH	29 1/8"
OVERALL HEIGHT	29 1/2"
WEIGHT	265 lbs.

BIKE LOCK LOOP

ANOVA FURNISHINGS



LBRCP SURF
MARQUEE BIKE RACK
 3-bike capacity, powder coated,
 surface mount bike rack

MARQUEE BIKE RACK : \$200.00

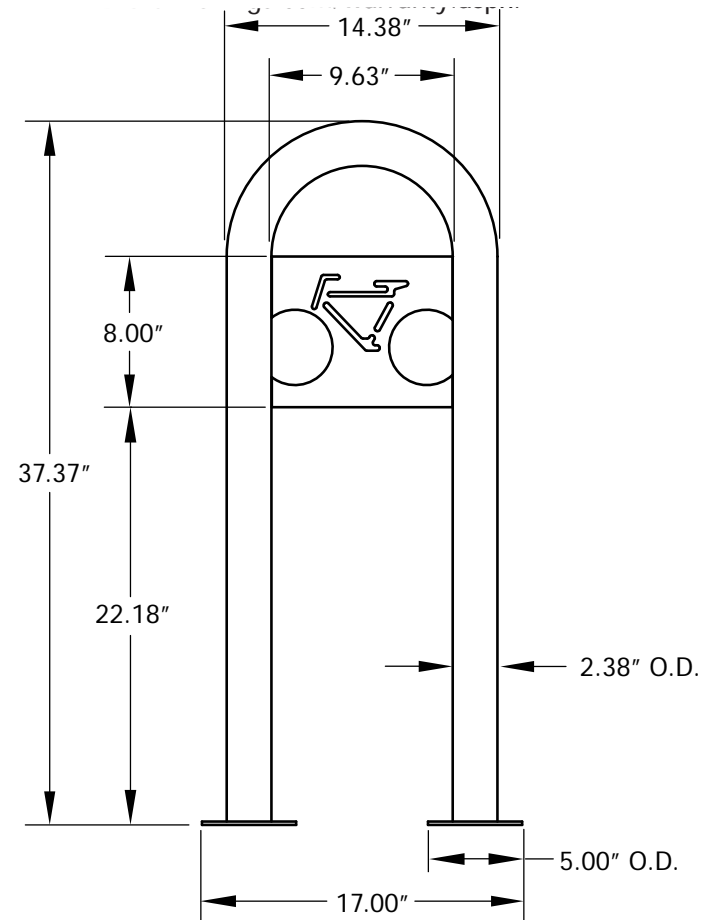

Material

The bike rack is 14.38" wide and can accommodate 3 bicycles. The rack is made from 2.38" O.D. x 10-gauge wall steel tubing. The product is protected by a fade resistant powder coat finish featuring a state of the art primer proven to prevent rusting. The legs feature a 5" diameter mounting plate with predrilled holes for surface attachment. Mounting hardware is not included.

Finish

Fade-resistant powder coated steel components feature a state-of-the art primer proven to prevent rusting. Treated components exceed the industry standard by 34% in testing by independent sources.

Color

See website or sales representative for color choices.

Assembly

The bike rack requires no assembly except for the surface mounting.

Maintenance

The product is virtually maintenance-free and requires only periodic cleaning with a sponge and a solution of mild detergent and water to remove surface dirt. Do not clean with solvent or petroleum based products.

Warranty

20-year limited structural warranty with 7-year finish warranty against fading from the date of purchase. See full details on multi-year warranties for components at www.anovafurnishings.com/warranty.aspx.

Shipping Information

Unit Wt.	Unit Shipping Wt. UPS (1-2 Units)	Unit Shipping Wt. Truck (3+ Units)	Unit Ship Size w/Pallet	Max Units per Pallet	Pallet Wt. (48" x 32")	Total No. Pkgs	Shipping Class
19 lbs	24 lbs/unit	24 lbs/unit	11 cu. ft.	12	50 lbs	1	70

Made in USA

Revised: 02/11/13-3

Copyright © 2013 ANOVA™



LIGHTING

CYCLONE LIGHTING

30' GULL WING LED & 1 ORNAMENTAL LIGHT : \$14,680.00

LIGHT POLE FEATURES:

- LED FIXTURES
- PENDANT LIGHT OVER SIDEWALK
- FLAG POLE HOLDER OVER PENDANT LIGHT
- BANNER ARMS
- SEASONAL DECORATION BRACKETS
- ELECTRICAL RECEPTACLE
- DARK BRONZE COLOR FACTORY PAINTED

