

# Alliant Engineering

Minneapolis, MN 55415

--TRAFFIC DATA --

I-35E at TH-110, west ramps  
 Ref.Pt.: 101.018  
 data by Alliant Engineering  
 TURN MOVEMENT COUNT

File Name : 413 - TH 110 and I-35E W Ramp  
 Site Code : 413  
 Start Date : 4/9/2015  
 Page No : 1

Groups Printed- Cars - Trucks

Start Time	n/a Southbound				TH-110 Westbound				ramp to I-35E SB Northbound				TH-110 Eastbound				Int. Total
	Left	Thru	Rght	Bikes	Left	Thru	Rght	Bikes	Left	Thru	Rght	Bikes	Left	Thru	Rght	Bikes	
06:00	0	0	0	0	13	137	0	0	0	0	0	0	0	46	5	0	201
06:15	0	0	0	0	15	198	0	0	0	0	0	0	0	50	6	0	269
06:30	0	0	0	0	14	268	0	0	0	0	0	0	0	98	7	1	388
06:45	0	0	0	0	37	393	0	0	0	0	0	0	0	114	7	0	551
Total	0	0	0	0	79	996	0	0	0	0	0	0	0	308	25	1	1409
07:00	0	0	0	0	23	351	0	0	0	0	0	0	0	132	8	0	514
07:15	0	0	0	0	41	376	0	0	0	0	0	0	0	150	13	0	580
07:30	0	0	0	0	55	398	0	0	0	0	0	0	0	172	17	0	642
07:45	0	0	0	0	53	348	0	0	0	0	0	0	0	214	40	1	656
Total	0	0	0	0	172	1473	0	0	0	0	0	0	0	668	78	1	2392
08:00	0	0	0	0	60	328	0	0	0	0	0	0	0	202	17	0	607
08:15	0	0	0	0	42	289	0	0	0	0	0	0	0	193	17	0	541
08:30	0	0	0	0	36	306	0	0	0	0	0	0	0	149	18	0	509
08:45	0	0	0	0	50	283	0	0	0	0	0	0	0	182	22	0	537
Total	0	0	0	0	188	1206	0	0	0	0	0	0	0	726	74	0	2194
09:00	0	0	0	0	37	208	0	0	0	0	0	0	0	155	17	0	417
09:15	0	0	0	0	35	199	0	0	0	0	0	0	0	147	18	0	399
*** BREAK ***																	
Total	0	0	0	0	72	407	0	0	0	0	0	0	0	302	35	0	816
*** BREAK ***																	
10:30	0	0	0	0	12	153	0	0	0	0	0	0	0	143	17	0	325
10:45	0	0	0	0	17	165	0	0	0	0	0	0	0	153	23	0	358
Total	0	0	0	0	29	318	0	0	0	0	0	0	0	296	40	0	683
11:00	0	0	0	0	19	143	0	0	0	0	0	0	0	124	15	0	301
11:15	0	0	0	0	25	142	0	0	0	0	0	0	0	162	27	0	356
11:30	0	0	0	0	27	165	0	0	0	0	0	0	0	154	26	0	372
11:45	0	0	0	0	38	209	0	0	0	0	0	0	0	172	21	0	440
Total	0	0	0	0	109	659	0	0	0	0	0	0	0	612	89	0	1469
12:00	0	0	0	0	38	148	0	0	0	0	0	0	0	166	22	0	374
12:15	0	0	0	0	44	176	0	0	0	0	0	0	0	167	24	0	411
12:30	0	0	0	0	38	179	0	0	0	0	0	0	0	167	11	0	395
12:45	0	0	0	0	40	154	0	0	0	0	0	0	0	174	17	0	385
Total	0	0	0	0	160	657	0	0	0	0	0	0	0	674	74	0	1565
13:00	0	0	0	0	31	150	0	0	0	0	0	0	0	169	19	0	369
13:15	0	0	0	0	32	122	0	0	0	0	0	0	0	150	20	0	324
*** BREAK ***																	
Total	0	0	0	0	63	272	0	0	0	0	0	0	0	319	39	0	693
*** BREAK ***																	
14:30	0	0	0	0	53	150	0	0	0	0	0	0	0	214	27	13	457
14:45	0	0	0	0	31	150	0	0	0	0	0	0	0	277	37	0	495
Total	0	0	0	0	84	300	0	0	0	0	0	0	0	491	64	13	952
15:00	0	0	0	0	45	156	0	0	0	0	0	0	0	253	26	0	480
15:15	0	0	0	0	51	156	0	0	0	0	0	0	0	294	27	0	528
15:30	0	0	0	0	68	170	0	0	0	0	0	0	0	304	34	0	576
15:45	0	0	0	0	45	166	0	0	0	0	0	0	0	397	44	0	652
Total	0	0	0	0	209	648	0	0	0	0	0	0	0	1248	131	0	2236
16:00	0	0	0	0	51	159	0	0	0	0	0	0	0	327	31	1	569
16:15	0	0	0	0	65	175	0	0	0	0	0	0	0	399	46	0	685
16:30	0	0	0	0	55	199	0	0	0	0	0	0	0	355	39	0	648

# Alliant Engineering

Minneapolis, MN 55415

--TRAFFIC DATA --

I-35E at TH-110, west ramps  
 Ref.Pt.: 101.018  
 data by Alliant Engineering  
 TURN MOVEMENT COUNT

File Name : 413 - TH 110 and I-35E W Ramp  
 Site Code : 413  
 Start Date : 4/9/2015  
 Page No : 2

Groups Printed- Cars - Trucks

Start Time	n/a Southbound				TH-110 Westbound				ramp to I-35E SB Northbound				TH-110 Eastbound				Int. Total
	Left	Thru	Rght	Bikes	Left	Thru	Rght	Bikes	Left	Thru	Rght	Bikes	Left	Thru	Rght	Bikes	
16:45	0	0	0	0	74	191	0	0	0	0	0	0	0	428	70	0	763
Total	0	0	0	0	245	724	0	0	0	0	0	0	0	1509	186	1	2665
17:00	0	0	0	0	50	198	0	0	0	0	0	0	0	413	53	0	714
17:15	0	0	0	0	52	217	0	0	0	0	0	0	0	418	54	0	741
17:30	0	0	0	0	70	228	0	0	0	0	0	0	0	345	39	0	682
17:45	0	0	0	0	69	200	0	0	0	0	0	0	0	316	30	0	615
Total	0	0	0	0	241	843	0	0	0	0	0	0	0	1492	176	0	2752
*** BREAK ***																	
Grand Total	0	0	0	0	1651	8503	0	0	0	0	0	0	0	8645	1011	16	19826
Apprch %	0	0	0	0	16.3	83.7	0	0	0	0	0	0	0	89.4	10.5	0.2	
Total %	0	0	0	0	8.3	42.9	0	0	0	0	0	0	0	43.6	5.1	0.1	
Cars	0	0	0	0	1618	8337	0	0	0	0	0	0	0	8480	992	2	19429
% Cars	0	0	0	0	98	98	0	0	0	0	0	0	0	98.1	98.1	12.5	98
Trucks	0	0	0	0	33	166	0	0	0	0	0	0	0	165	19	14	397
% Trucks	0	0	0	0	2	2	0	0	0	0	0	0	0	1.9	1.9	87.5	2

# Alliant Engineering

Minneapolis, MN 55415

--TRAFFIC DATA --

I-35E at TH-110, west ramps  
 Ref.Pt.: 101.018  
 data by Alliant Engineering  
 TURN MOVEMENT COUNT

File Name : 413 - TH 110 and I-35E W Ramp  
 Site Code : 413  
 Start Date : 4/9/2015  
 Page No : 3

Start Time	n/a Southbound					TH-110 Westbound					ramp to I-35E SB Northbound					TH-110 Eastbound					Int. Total
	Left	Thru	Right	Bikes	App. Total	Left	Thru	Right	Bikes	App. Total	Left	Thru	Right	Bikes	App. Total	Left	Thru	Right	Bikes	App. Total	
Peak Hour Analysis From 06:00 to 11:45 - Peak 1 of 1																					
Peak Hour for Entire Intersection Begins at 07:15																					
07:15	0	0	0	0	0	41	376	0	0	417	0	0	0	0	0	0	150	13	0	163	580
07:30	0	0	0	0	0	55	<b>398</b>	0	0	<b>453</b>	0	0	0	0	0	0	172	17	0	189	642
07:45	0	0	0	0	0	53	348	0	0	401	0	0	0	0	0	0	<b>214</b>	<b>40</b>	<b>1</b>	<b>255</b>	<b>656</b>
08:00	0	0	0	0	0	<b>60</b>	328	0	0	388	0	0	0	0	0	0	202	17	0	219	607
Total Volume	0	0	0	0	0	209	1450	0	0	1659	0	0	0	0	0	0	738	87	1	826	2485
% App. Total	0	0	0	0	0	12.6	87.4	0	0		0	0	0	0	0	0	89.3	10.5	0.1		
PHF	.000	.000	.000	.000	.000	.871	.911	.000	.000	.916	.000	.000	.000	.000	.000	.000	.862	.544	.250	.810	.947

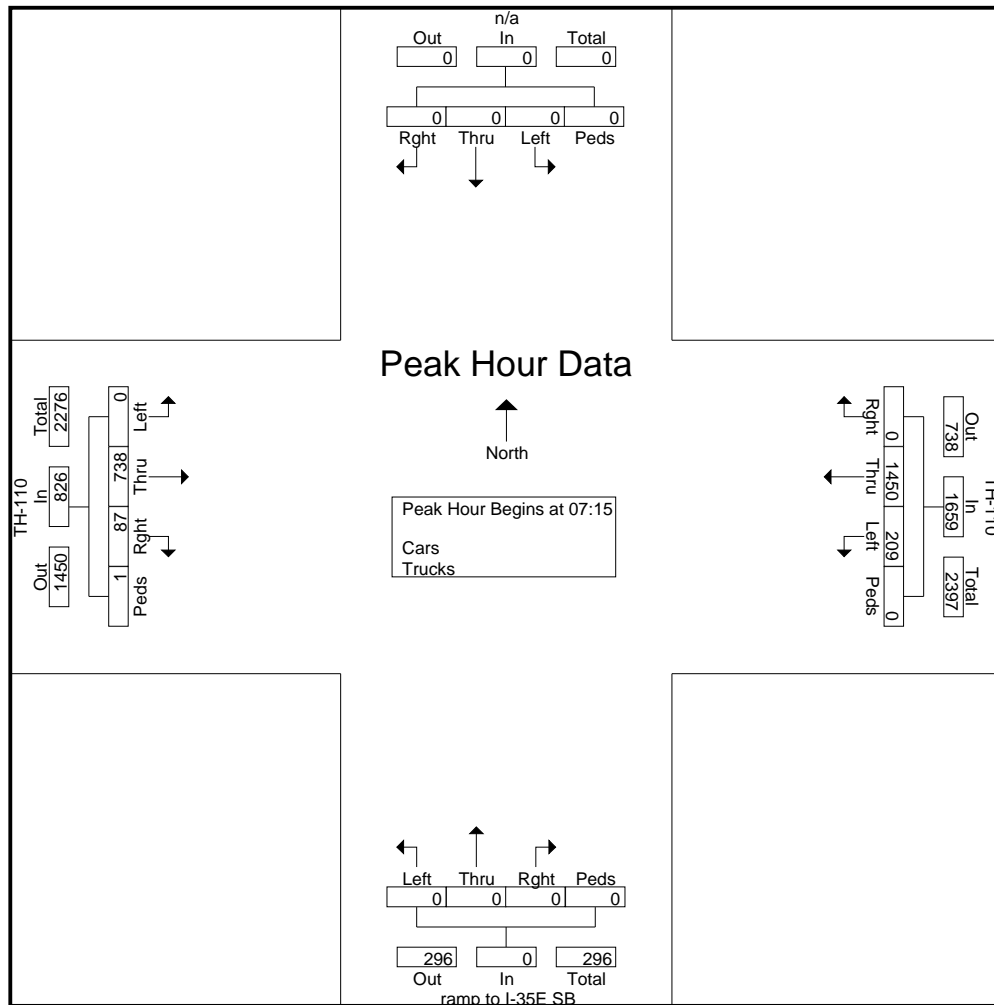

# Alliant Engineering

Minneapolis, MN 55415

--TRAFFIC DATA --

I-35E at TH-110, west ramps  
 Ref.Pt.: 101.018  
 data by Alliant Engineering  
 TURN MOVEMENT COUNT

File Name : 413 - TH 110 and I-35E W Ramp  
 Site Code : 413  
 Start Date : 4/9/2015  
 Page No : 4

Start Time	n/a Southbound					TH-110 Westbound					ramp to I-35E SB Northbound					TH-110 Eastbound					Int. Total
	Left	Thru	Rght	Bikes	App. Total	Left	Thru	Rght	Bikes	App. Total	Left	Thru	Rght	Bikes	App. Total	Left	Thru	Rght	Bikes	App. Total	
Peak Hour Analysis From 12:00 to 18:00 - Peak 1 of 1																					
Peak Hour for Entire Intersection Begins at 16:45																					
16:45	0	0	0	0	0	74	191	0	0	265	0	0	0	0	0	0	428	70	0	498	763
17:00	0	0	0	0	0	50	198	0	0	248	0	0	0	0	0	0	413	53	0	466	714
17:15	0	0	0	0	0	52	217	0	0	269	0	0	0	0	0	0	418	54	0	472	741
17:30	0	0	0	0	0	70	228	0	0	298	0	0	0	0	0	0	345	39	0	384	682
Total Volume	0	0	0	0	0	246	834	0	0	1080	0	0	0	0	0	0	1604	216	0	1820	2900
% App. Total	0	0	0	0	0	22.8	77.2	0	0		0	0	0	0	0	0	88.1	11.9	0		
PHF	.000	.000	.000	.000	.000	.831	.914	.000	.000	.906	.000	.000	.000	.000	.000	.000	.937	.771	.000	.914	.950

