



MINNESOTA DEPT OF TRANSPORTATION

TRAFFIC DATA COLLECTION - METRO

I-35E (NB) at Co.Rd.E , east ramps
 Ref.Pt.: 115.254
 video MD
 TURN MOVEMENT COUNT

File Name : I-35E at CoRdE East Ramps 2014
 Site Code :
 Start Date : 2/4/2014
 Page No : 1

Groups Printed- Cars +

Start Time	ramp to I-35E NB Southbound				Co.Rd. E Westbound				ramp from I-35E NB Northbound				Co.Rd. E Eastbound				Int. Total
	Right	Thru	Left	Peds	Right	Thru	Left	Peds	Right	Thru	Left	Peds	Right	Thru	Left	Peds	
06:00	0	0	0	0	2	42	0	0	70	0	16	0	0	55	3	0	188
06:15	0	0	0	0	13	46	0	0	91	0	16	0	0	54	7	0	227
06:30	0	0	0	0	18	71	0	0	78	0	18	0	0	78	13	0	276
06:45	0	0	0	0	22	65	0	0	93	2	21	0	0	94	6	0	303
Total	0	0	0	0	55	224	0	0	332	2	71	0	0	281	29	0	994
07:00	0	0	0	0	21	64	0	0	98	0	36	0	0	95	10	0	324
07:15	0	0	0	0	26	63	0	0	157	0	31	0	0	132	16	0	425
07:30	0	0	0	0	27	81	0	0	123	0	35	0	0	145	14	0	425
07:45	0	0	0	0	29	97	0	0	155	2	58	0	0	145	15	0	501
Total	0	0	0	0	103	305	0	0	533	2	160	0	0	517	55	0	1675
08:00	0	0	0	0	45	99	0	0	156	1	73	0	0	103	10	0	487
08:15	0	0	0	0	32	90	0	0	105	1	51	0	0	84	5	0	368
08:30	0	0	0	0	33	91	0	0	113	4	59	0	0	96	14	0	410
08:45	0	0	0	0	22	92	12	0	165	14	130	0	0	163	35	0	633
Total	0	0	0	0	132	372	12	0	539	20	313	0	0	446	64	0	1898
***** BREAK *****																	
15:00	0	0	0	0	56	152	0	0	89	0	87	0	0	94	36	0	514
15:15	0	0	0	0	64	175	0	0	92	0	90	0	0	118	45	0	584
15:30	0	0	0	0	77	182	0	0	109	0	117	0	0	118	56	0	659
15:45	0	0	0	0	67	175	0	0	95	0	97	0	0	115	48	0	597
Total	0	0	0	0	264	684	0	0	385	0	391	0	0	445	185	0	2354
16:00	0	0	0	0	93	209	0	0	112	0	88	0	0	141	43	0	686
16:15	0	0	0	0	78	143	0	0	88	2	100	0	0	143	48	0	602
16:30	0	0	0	0	119	201	0	0	102	1	117	0	0	119	32	0	691
16:45	0	0	0	0	96	206	0	0	101	1	102	0	0	136	49	0	691
Total	0	0	0	0	386	759	0	0	403	4	407	0	0	539	172	0	2670
17:00	0	0	0	0	110	209	0	0	70	0	122	0	0	127	41	0	679
17:15	0	0	0	0	95	199	0	0	69	1	109	0	0	154	46	0	673
17:30	0	0	0	0	63	163	0	0	95	0	119	0	0	128	40	0	608
17:45	0	0	0	0	69	189	0	0	77	0	113	0	0	165	52	0	665
Total	0	0	0	0	337	760	0	0	311	1	463	0	0	574	179	0	2625
Grand Total	0	0	0	0	1277	3104	12	0	2503	29	1805	0	0	2802	684	0	12216
Apprch %	0	0	0	0	29.1	70.7	0.3	0	57.7	0.7	41.6	0	0	80.4	19.6	0	
Total %	0	0	0	0	10.5	25.4	0.1	0	20.5	0.2	14.8	0	0	22.9	5.6	0	



MINNESOTA DEPT OF TRANSPORTATION

TRAFFIC DATA COLLECTION - METRO

I-35E (NB) at Co.Rd.E , east ramps
 Ref.Pt.: 115.254
 video MD
 TURN MOVEMENT COUNT

File Name : I-35E at CoRdE East Ramps 2014
 Site Code :
 Start Date : 2/4/2014
 Page No : 2

Start Time	ramp to I-35E NB Southbound					Co.Rd. E Westbound					ramp from I-35E NB Northbound					Co.Rd. E Eastbound					Int. Total
	Right	Thru	Left	Peds	App. Total	Right	Thru	Left	Peds	App. Total	Right	Thru	Left	Peds	App. Total	Right	Thru	Left	Peds	App. Total	
Peak Hour Analysis From 06:00 to 08:45 - Peak 1 of 1																					
Peak Hour for Entire Intersection Begins at 08:00																					
08:00	0	0	0	0	0	45	99	0	0	144	156	1	73	0	230	0	103	10	0	113	487
08:15	0	0	0	0	0	32	90	0	0	122	105	1	51	0	157	0	84	5	0	89	368
08:30	0	0	0	0	0	33	91	0	0	124	113	4	59	0	176	0	96	14	0	110	410
08:45	0	0	0	0	0	22	92	12	0	126	165	14	130	0	309	0	163	35	0	198	633
Total Volume	0	0	0	0	0	132	372	12	0	516	539	20	313	0	872	0	446	64	0	510	1898
% App. Total	0	0	0	0	0	25.6	72.1	2.3	0		61.8	2.3	35.9	0		0	87.5	12.5	0		
PHF	.000	.000	.000	.000	.000	.733	.939	.250	.000	.896	.817	.357	.602	.000	.706	.000	.684	.457	.000	.644	.750

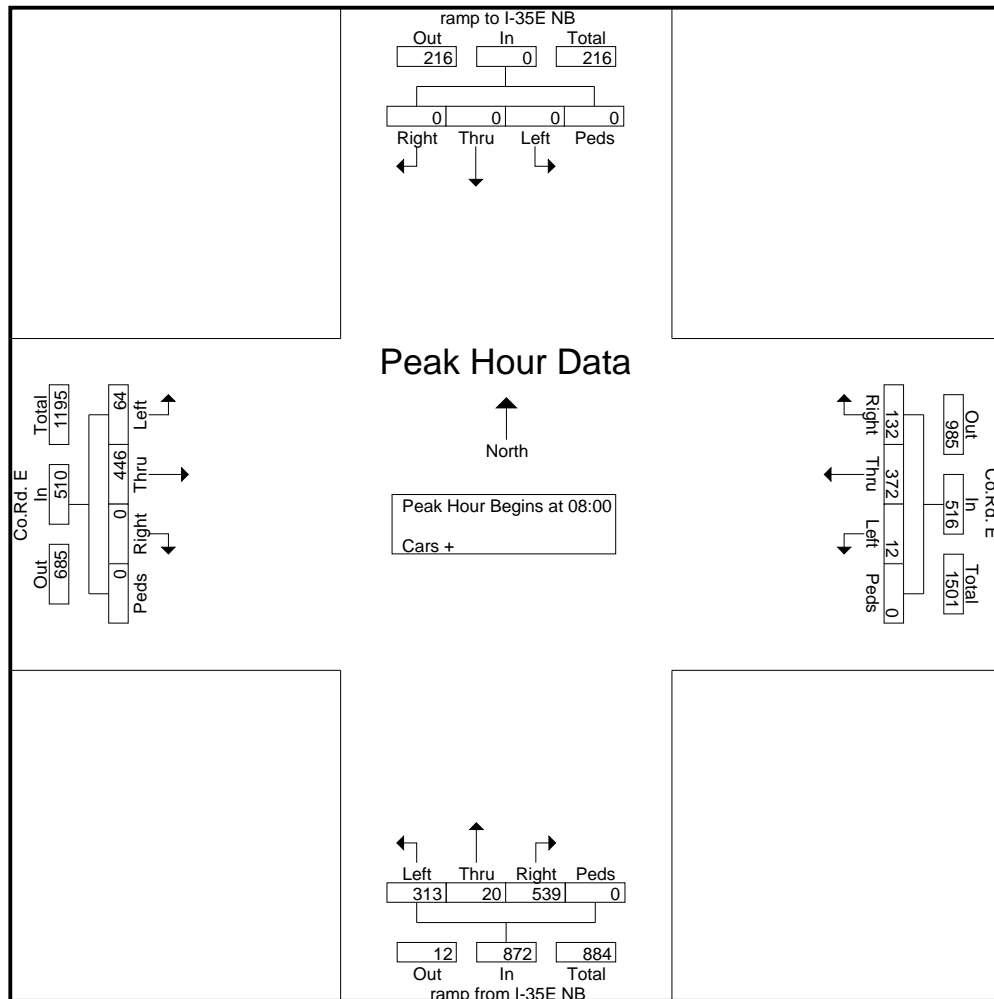



MINNESOTA DEPT OF TRANSPORTATION

TRAFFIC DATA COLLECTION - METRO

I-35E (NB) at Co.Rd.E , east ramps
 Ref.Pt.: 115.254
 video MD
 TURN MOVEMENT COUNT

File Name : I-35E at CoRdE East Ramps 2014
 Site Code :
 Start Date : 2/4/2014
 Page No : 3

Start Time	ramp to I-35E NB Southbound					Co.Rd. E Westbound					ramp from I-35E NB Northbound					Co.Rd. E Eastbound					Int. Total
	Right	Thru	Left	Peds	App. Total	Right	Thru	Left	Peds	App. Total	Right	Thru	Left	Peds	App. Total	Right	Thru	Left	Peds	App. Total	
16:30	0	0	0	0	0	119	201	0	0	320	102	1	117	0	220	0	119	32	0	151	691
16:45	0	0	0	0	0	96	206	0	0	302	101	1	102	0	204	0	136	49	0	185	691
17:00	0	0	0	0	0	110	209	0	0	319	70	0	122	0	192	0	127	41	0	168	679
17:15	0	0	0	0	0	95	199	0	0	294	69	1	109	0	179	0	154	46	0	200	673
Total Volume	0	0	0	0	0	420	815	0	0	1235	342	3	450	0	795	0	536	168	0	704	2734
% App. Total	0	0	0	0	0	34	66	0	0	0	43	0.4	56.6	0	0	0	76.1	23.9	0	0	0
PHF	.000	.000	.000	.000	.000	.882	.975	.000	.000	.965	.838	.750	.922	.000	.903	.000	.870	.857	.000	.880	.989

Peak Hour Analysis From 15:00 to 17:45 - Peak 1 of 1
 Peak Hour for Entire Intersection Begins at 16:30

