

Alliant Engineering, Inc.

733 Marquette Ave #700, Minneapolis, MN 55402

Prairie Center Dr & Viking Dr
 Ref Pt:
 data by: Alliant Inc
 TURN MOVEMENT COUNT

File Name : 15_EP_Prairie Center Dr at Viking Dr
 Site Code :
 Start Date : 12/14/2020
 Page No : 1

Groups Printed- Cars - Trucks

Start Time	Prairie Center Dr Southbound					Viking Dr Westbound					Prairie Center Dr Northbound					Viking Dr Eastbound					Int. Total
	Right	Thru	Left	Peds	App. Total	Right	Thru	Left	Peds	App. Total	Right	Thru	Left	Peds	App. Total	Right	Thru	Left	Peds	App. Total	
06:00 AM	0	10	2	0	12	0	0	1	0	1	3	18	0	0	21	0	1	0	0	1	35
06:15 AM	0	6	2	1	9	0	0	0	0	0	7	22	0	0	29	0	0	0	0	0	38
06:30 AM	0	18	4	3	25	3	0	3	0	6	7	48	0	0	55	0	0	0	0	0	86
06:45 AM	0	19	3	0	22	0	0	1	0	1	10	54	1	0	65	0	3	3	0	6	94
Total	0	53	11	4	68	3	0	5	0	8	27	142	1	0	170	0	4	3	0	7	253
07:00 AM	0	17	6	0	23	2	0	2	0	4	13	49	3	0	65	1	1	1	0	3	95
07:15 AM	1	27	2	0	30	4	0	4	0	8	13	61	1	0	75	1	1	1	0	3	116
07:30 AM	2	35	10	0	47	2	0	3	0	5	13	72	2	0	87	3	0	3	0	6	145
07:45 AM	3	65	13	0	81	5	3	3	0	11	14	92	5	0	111	3	1	0	0	4	207
Total	6	144	31	0	181	13	3	12	0	28	53	274	11	0	338	8	3	5	0	16	563
08:00 AM	0	41	10	0	51	3	0	7	0	10	12	66	2	0	80	2	3	1	0	6	147
08:15 AM	1	36	11	0	48	9	1	6	0	16	8	55	4	0	67	1	1	1	0	3	134
08:30 AM	2	53	7	0	62	8	4	9	0	21	13	70	1	0	84	1	1	1	0	3	170
08:45 AM	2	42	6	0	50	4	2	4	0	10	7	65	7	0	79	0	0	0	0	0	139
Total	5	172	34	0	211	24	7	26	0	57	40	256	14	0	310	4	5	3	0	12	590
09:00 AM	1	56	3	0	60	4	3	10	0	17	7	47	5	4	63	1	1	2	0	4	144
09:15 AM	0	44	5	0	49	6	0	1	0	7	13	48	4	0	65	3	2	2	0	7	128
*** BREAK ***																					
Total	1	100	8	0	109	10	3	11	0	24	20	95	9	4	128	4	3	4	0	11	272
*** BREAK ***																					
10:30 AM	0	63	1	0	64	7	1	9	0	17	9	60	2	0	71	5	1	3	1	10	162
10:45 AM	2	66	3	0	71	8	4	8	0	20	4	61	2	0	67	3	0	1	0	4	162
Total	2	129	4	0	135	15	5	17	0	37	13	121	4	0	138	8	1	4	1	14	324
11:00 AM	0	83	2	0	85	6	1	16	0	23	10	46	1	0	57	1	1	1	0	3	168
11:15 AM	3	74	1	0	78	5	2	19	0	26	13	68	5	0	86	7	2	1	0	10	200
11:30 AM	2	73	1	0	76	8	1	22	0	31	14	69	3	0	86	5	3	1	0	9	202
11:45 AM	1	83	7	0	91	8	2	21	0	31	17	84	3	0	104	3	1	2	0	6	232
Total	6	313	11	0	330	27	6	78	0	111	54	267	12	0	333	16	7	5	0	28	802
12:00 PM	1	80	8	0	89	6	5	20	0	31	17	59	6	0	82	9	1	0	0	10	212
12:15 PM	2	76	3	0	81	9	10	19	0	38	15	82	3	0	100	6	3	2	0	11	230
12:30 PM	1	82	9	0	92	14	4	22	0	40	15	114	3	0	132	3	5	3	0	11	275
12:45 PM	2	87	9	0	98	10	4	12	0	26	15	86	6	0	107	4	3	2	0	9	240
Total	6	325	29	0	360	39	23	73	0	135	62	341	18	0	421	22	12	7	0	41	957
01:00 PM	3	76	7	0	86	8	2	14	0	24	19	85	8	0	112	8	4	0	1	13	235
01:15 PM	0	75	7	0	82	12	0	8	0	20	20	78	3	0	101	4	1	0	0	5	208
*** BREAK ***																					
Total	3	151	14	0	168	20	2	22	0	44	39	163	11	0	213	12	5	0	1	18	443
*** BREAK ***																					
02:30 PM	0	79	1	0	80	8	1	12	0	21	8	80	3	0	91	8	1	0	0	9	201
02:45 PM	1	77	8	0	86	15	1	11	0	27	10	75	11	0	96	12	2	0	0	14	223
Total	1	156	9	0	166	23	2	23	0	48	18	155	14	0	187	20	3	0	0	23	424
03:00 PM	1	85	2	0	88	5	1	9	0	15	2	87	2	0	91	9	0	1	0	10	204
03:15 PM	4	104	4	0	112	15	2	10	0	27	5	100	6	0	111	2	1	1	0	4	254
03:30 PM	0	82	4	0	86	19	2	18	0	39	5	76	4	0	85	5	0	0	0	5	215
03:45 PM	1	110	1	0	112	17	2	13	0	32	8	79	6	0	93	4	0	1	0	5	242
Total	6	381	11	0	398	56	7	50	0	113	20	342	18	0	380	20	1	3	0	24	915
04:00 PM	4	110	2	0	116	26	2	11	0	39	6	78	1	0	85	2	0	1	0	3	243

Alliant Engineering, Inc.

733 Marquette Ave #700, Minneapolis, MN 55402

Prairie Center Dr & Viking Dr
 Ref Pt:
 data by: Alliant Inc
 TURN MOVEMENT COUNT

File Name : 15_EP_Prairie Center Dr at Viking Dr
 Site Code :
 Start Date : 12/14/2020
 Page No : 2

Groups Printed- Cars - Trucks

Start Time	Prairie Center Dr Southbound					Viking Dr Westbound					Prairie Center Dr Northbound					Viking Dr Eastbound					Int. Total
	Right	Thru	Left	Peds	App. Total	Right	Thru	Left	Peds	App. Total	Right	Thru	Left	Peds	App. Total	Right	Thru	Left	Peds	App. Total	
04:15 PM	3	102	5	0	110	15	3	12	0	30	10	102	7	0	119	7	0	0	0	7	266
04:30 PM	1	111	6	0	118	23	3	19	0	45	7	98	4	0	109	12	1	1	0	14	286
04:45 PM	0	96	3	0	99	16	1	14	0	31	5	74	5	0	84	7	0	1	0	8	222
Total	8	419	16	0	443	80	9	56	0	145	28	352	17	0	397	28	1	3	0	32	1017
05:00 PM	4	97	4	0	105	17	3	9	0	29	6	126	8	0	140	9	0	3	0	12	286
05:15 PM	1	101	2	0	104	17	1	8	0	26	6	111	12	0	129	15	0	1	0	16	275
05:30 PM	0	74	1	0	75	8	3	11	0	22	6	94	9	0	109	4	0	2	0	6	212
05:45 PM	2	84	7	0	93	8	1	9	0	18	4	78	4	0	86	9	2	0	0	11	208
Total	7	356	14	0	377	50	8	37	0	95	22	409	33	0	464	37	2	6	0	45	981
Grand Total	51	2699	192	4	2946	360	75	410	0	845	396	2917	162	4	3479	179	47	43	2	271	7541
Apprch %	1.7	91.6	6.5	0.1		42.6	8.9	48.5	0		11.4	83.8	4.7	0.1		66.1	17.3	15.9	0.7		
Total %	0.7	35.8	2.5	0.1	39.1	4.8	1	5.4	0	11.2	5.3	38.7	2.1	0.1	46.1	2.4	0.6	0.6	0	3.6	
Cars	49	2645	187	3	2884	345	73	402	0	820	382	2852	161	4	3399	177	45	39	2	263	7366
% Cars	96.1	98	97.4	75	97.9	95.8	97.3	98	0	97	96.5	97.8	99.4	100	97.7	98.9	95.7	90.7	100	97	97.7
Trucks	2	54	5	1	62	15	2	8	0	25	14	65	1	0	80	2	2	4	0	8	175
% Trucks	3.9	2	2.6	25	2.1	4.2	2.7	2	0	3	3.5	2.2	0.6	0	2.3	1.1	4.3	9.3	0	3	2.3

Alliant Engineering, Inc.

733 Marquette Ave #700, Minneapolis, MN 55402

Prairie Center Dr & Viking Dr
 Ref Pt:
 data by: Alliant Inc
 TURN MOVEMENT COUNT

File Name : 15_EP_Prairie Center Dr at Viking Dr
 Site Code :
 Start Date : 12/14/2020
 Page No : 3

Start Time	Prairie Center Dr Southbound					Viking Dr Westbound					Prairie Center Dr Northbound					Viking Dr Eastbound					Int. Total
	Right	Thru	Left	Peds	App. Total	Right	Thru	Left	Peds	App. Total	Right	Thru	Left	Peds	App. Total	Right	Thru	Left	Peds	App. Total	
Peak Hour Analysis From 06:00 AM to 09:45 AM - Peak 1 of 1																					
Peak Hour for Entire Intersection Begins at 07:45 AM																					
07:45 AM	3	65	13	0	81	5	3	3	0	11	14	92	5	0	111	3	1	0	0	4	207
08:00 AM	0	41	10	0	51	3	0	7	0	10	12	66	2	0	80	2	3	1	0	6	147
08:15 AM	1	36	11	0	48	9	1	6	0	16	8	55	4	0	67	1	1	1	0	3	134
08:30 AM	2	53	7	0	62	8	4	9	0	21	13	70	1	0	84	1	1	1	0	3	170
Total Volume	6	195	41	0	242	25	8	25	0	58	47	283	12	0	342	7	6	3	0	16	658
% App. Total	2.5	80.6	16.9	0		43.1	13.8	43.1	0		13.7	82.7	3.5	0		43.8	37.5	18.8	0		
PHF	.500	.750	.788	.000	.747	.694	.500	.694	.000	.690	.839	.769	.600	.000	.770	.583	.500	.750	.000	.667	.795

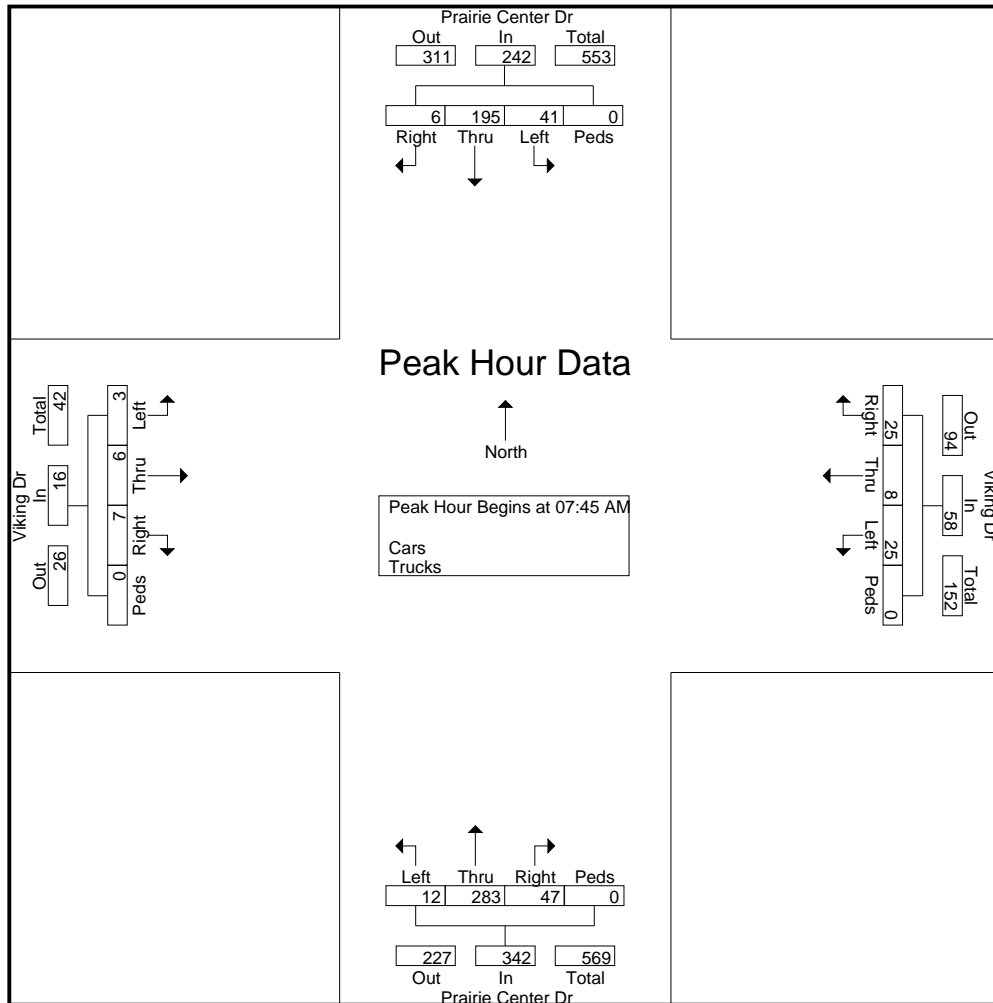

Alliant Engineering, Inc.

733 Marquette Ave #700, Minneapolis, MN 55402

Prairie Center Dr & Viking Dr
 Ref Pt:
 data by: Alliant Inc
 TURN MOVEMENT COUNT

File Name : 15_EP_Prairie Center Dr at Viking Dr
 Site Code :
 Start Date : 12/14/2020
 Page No : 4

Start Time	Prairie Center Dr Southbound					Viking Dr Westbound					Prairie Center Dr Northbound					Viking Dr Eastbound					Int. Total
	Right	Thru	Left	Peds	App. Total	Right	Thru	Left	Peds	App. Total	Right	Thru	Left	Peds	App. Total	Right	Thru	Left	Peds	App. Total	
Peak Hour Analysis From 10:00 AM to 01:45 PM - Peak 1 of 1																					
Peak Hour for Entire Intersection Begins at 12:15 PM																					
12:15 PM	2	76	3	0	81	9	10	19	0	38	15	82	3	0	100	6	3	2	0	11	230
12:30 PM	1	82	9	0	92	14	4	22	0	40	15	114	3	0	132	3	5	3	0	11	275
12:45 PM	2	87	9	0	98	10	4	12	0	26	15	86	6	0	107	4	3	2	0	9	240
01:00 PM	3	76	7	0	86	8	2	14	0	24	19	85	8	0	112	8	4	0	1	13	235
Total Volume	8	321	28	0	357	41	20	67	0	128	64	367	20	0	451	21	15	7	1	44	980
% App. Total	2.2	89.9	7.8	0		32	15.6	52.3	0		14.2	81.4	4.4	0		47.7	34.1	15.9	2.3		
PHF	.667	.922	.778	.000	.911	.732	.500	.761	.000	.800	.842	.805	.625	.000	.854	.656	.750	.583	.250	.846	.891

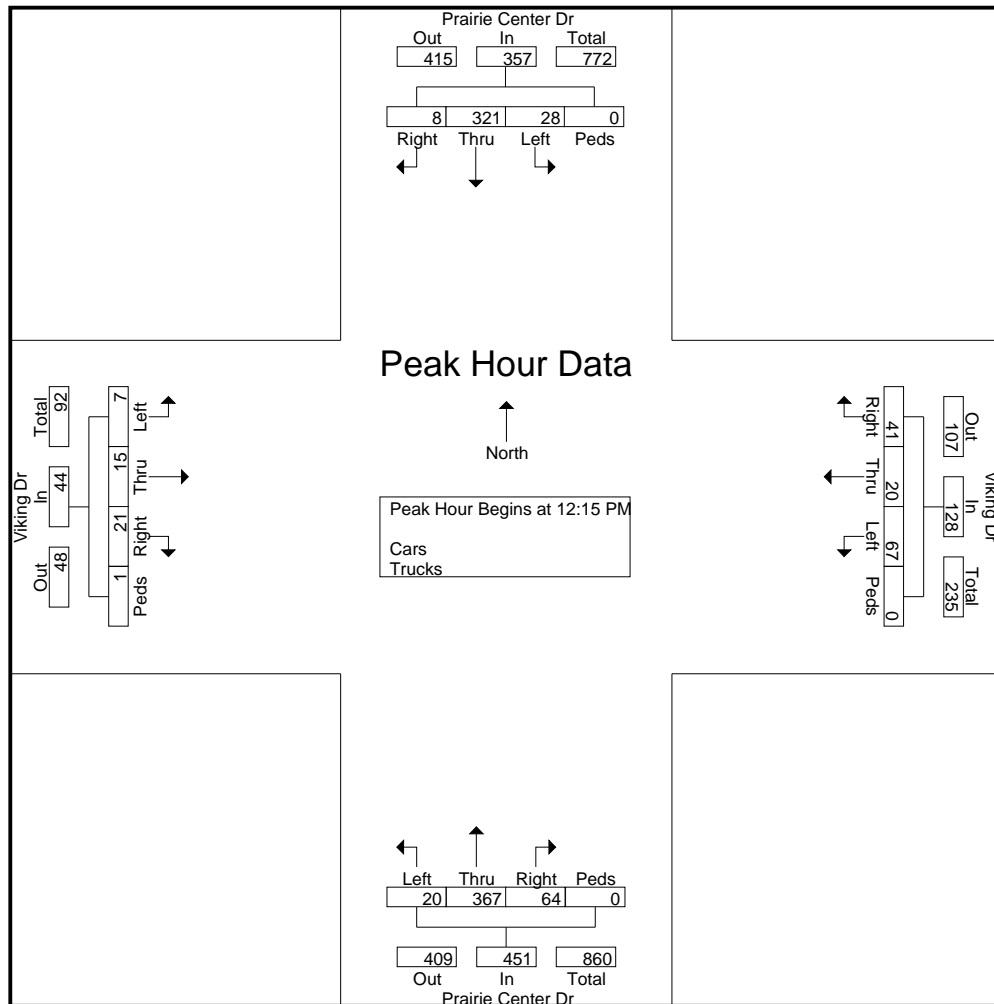

Alliant Engineering, Inc.

733 Marquette Ave #700, Minneapolis, MN 55402

Prairie Center Dr & Viking Dr
 Ref Pt:
 data by: Alliant Inc
 TURN MOVEMENT COUNT

File Name : 15_EP_Prairie Center Dr at Viking Dr
 Site Code :
 Start Date : 12/14/2020
 Page No : 5

Start Time	Prairie Center Dr Southbound					Viking Dr Westbound					Prairie Center Dr Northbound					Viking Dr Eastbound					Int. Total
	Right	Thru	Left	Peds	App. Total	Right	Thru	Left	Peds	App. Total	Right	Thru	Left	Peds	App. Total	Right	Thru	Left	Peds	App. Total	
Peak Hour Analysis From 02:00 PM to 05:45 PM - Peak 1 of 1																					
Peak Hour for Entire Intersection Begins at 04:30 PM																					
04:30 PM	1	111	6	0	118	23	3	19	0	45	7	98	4	0	109	12	1	1	0	14	286
04:45 PM	0	96	3	0	99	16	1	14	0	31	5	74	5	0	84	7	0	1	0	8	222
05:00 PM	4	97	4	0	105	17	3	9	0	29	6	126	8	0	140	9	0	3	0	12	286
05:15 PM	1	101	2	0	104	17	1	8	0	26	6	111	12	0	129	15	0	1	0	16	275
Total Volume	6	405	15	0	426	73	8	50	0	131	24	409	29	0	462	43	1	6	0	50	1069
% App. Total	1.4	95.1	3.5	0		55.7	6.1	38.2	0		5.2	88.5	6.3	0		86	2	12	0		
PHF	.375	.912	.625	.000	.903	.793	.667	.658	.000	.728	.857	.812	.604	.000	.825	.717	.250	.500	.000	.781	.934

