

Albeck Gerken, Inc

Transportation Engineers

Traffic Data Collection

I-94 at McKnight Rd, north ramps

File Name : 12 I-94 North Ramp & McKnight Rd

Site Code : 12

Ref.Pt.: 246.641

Start Date : 1/13/2012

TURN MOVEMENT COUNT

Page No : 1

Groups Printed- Cars - Heavy Vehicles

Start Time	McKnight Rd Southbound			N Hudson Rd / ramp from I-94 WB Westbound				McKnight Rd Northbound			ramp to I-94 WB Eastbound	Int. Total
	Thru	Right	Peds	Left	Thru	Right	Peds	Left	Thru	Peds	Peds	
06:00	25	44	0	5	4	3	0	25	82	0	0	188
06:15	53	57	0	7	8	10	0	33	129	0	0	297
06:30	41	77	0	9	6	7	0	61	162	0	0	363
06:45	47	61	0	8	15	18	0	45	193	0	0	387
Total	166	239	0	29	33	38	0	164	566	0	0	1235
07:00	79	82	0	20	10	7	0	53	209	0	1	461
07:15	68	85	0	29	15	20	1	58	261	0	0	537
07:30	90	80	0	27	16	14	0	59	323	0	0	609
07:45	86	72	0	12	11	25	0	38	366	0	0	610
Total	323	319	0	88	52	66	1	208	1159	0	1	2217
08:00	75	51	0	17	8	29	0	48	309	0	0	537
08:15	84	56	0	11	11	30	1	41	297	0	1	532
08:30	84	81	0	9	14	21	0	53	250	0	0	512
08:45	91	60	0	15	18	25	0	64	195	246	0	714
Total	334	248	0	52	51	105	1	206	1051	246	1	2295
09:00	65	42	0	19	21	18	0	39	160	0	0	364
09:15	62	61	0	9	17	13	0	42	111	0	0	315
09:30	59	50	0	7	24	19	0	42	119	0	1	321
09:45	58	42	0	10	15	14	0	29	93	0	1	262
Total	244	195	0	45	77	64	0	152	483	0	2	1262
10:00	51	38	0	12	15	10	0	33	80	0	1	240
10:15	84	46	0	13	23	10	0	29	64	0	2	271
10:30	64	35	0	17	29	9	0	34	91	0	1	280
10:45	75	46	0	13	31	12	0	24	87	0	1	289
Total	274	165	0	55	98	41	0	120	322	0	5	1080
11:00	75	59	0	20	56	6	0	40	84	0	0	340
11:15	100	55	0	30	50	17	0	42	84	0	3	381
11:30	127	59	0	33	53	20	3	45	90	0	0	430
11:45	104	50	0	28	48	18	0	29	96	0	1	374
Total	406	223	0	111	207	61	3	156	354	0	4	1525
12:00	93	52	0	35	64	13	2	33	91	0	0	383
12:15	95	41	0	25	47	17	5	38	111	0	0	379
12:30	94	55	0	19	35	11	1	48	124	0	0	387
12:45	90	41	0	29	31	15	3	45	134	0	0	388
Total	372	189	0	108	177	56	11	164	460	0	0	1537
13:00	89	59	0	20	47	13	0	46	126	0	0	400
13:15	106	49	0	12	35	17	0	35	132	0	1	387
13:30	89	43	0	16	24	20	0	48	103	0	2	345
13:45	97	52	0	20	35	12	0	50	91	0	0	357
Total	381	203	0	68	141	62	0	179	452	0	3	1489
14:00	96	60	0	27	24	14	0	40	86	0	0	347
14:15	109	48	0	30	23	14	0	32	105	0	2	363
14:30	109	79	0	36	27	15	0	50	91	0	2	409
14:45	117	59	0	32	36	39	0	39	119	0	1	442
Total	431	246	0	125	110	82	0	161	401	0	5	1561
15:00	144	88	0	36	53	28	0	36	85	1	1	472
15:15	138	58	0	38	47	16	0	43	104	0	4	448

Albeck Gerken, Inc

Transportation Engineers

Traffic Data Collection

I-94 at McKnight Rd, north ramps

File Name : 12 I-94 North Ramp & McKnight Rd

Site Code : 12

Ref.Pt.: 246.641

Start Date : 1/13/2012

TURN MOVEMENT COUNT

Page No : 2

Groups Printed- Cars - Heavy Vehicles

Start Time	McKnight Rd Southbound			N Hudson Rd / ramp from I-94 WB Westbound				McKnight Rd Northbound			ramp to I-94 WB Eastbound	Int. Total
	Thru	Right	Peds	Left	Thru	Right	Peds	Left	Thru	Peds	Peds	
15:30	154	77	0	31	46	10	0	56	127	0	1	502
15:45	124	82	0	51	43	26	0	38	116	0	4	484
Total	560	305	0	156	189	80	0	173	432	1	10	1906
16:00	147	111	0	71	61	32	0	44	94	0	0	560
16:15	202	105	0	67	58	19	0	41	145	0	1	638
16:30	188	121	0	96	68	38	0	56	152	0	1	720
16:45	195	119	0	92	73	24	0	45	148	0	1	697
Total	732	456	0	326	260	113	0	186	539	0	3	2615
17:00	203	133	0	79	76	22	0	44	133	0	1	691
17:15	187	104	0	79	82	42	0	46	128	0	0	668
17:30	165	113	0	57	54	28	0	46	117	0	1	581
17:45	178	81	0	45	67	29	1	57	129	0	1	588
Total	733	431	0	260	279	121	1	193	507	0	3	2528
18:00	130	74	0	50	53	22	0	36	94	0	0	459
18:15	133	66	0	34	30	34	0	50	85	0	2	434
18:30	104	55	0	19	24	31	0	51	93	0	1	378
18:45	117	41	0	31	39	20	0	47	89	0	0	384
Total	484	236	0	134	146	107	0	184	361	0	3	1655
Grand Total	5440	3455	0	1557	1820	996	17	2246	7087	247	40	22905
Apprch %	61.2	38.8	0	35.5	41.5	22.7	0.4	23.4	74	2.6	100	
Total %	23.8	15.1	0	6.8	7.9	4.3	0.1	9.8	30.9	1.1	0.2	
Cars	5197	3326	0	1525	1791	956	17	2155	6833	247	40	22087
% Cars	95.5	96.3	0	97.9	98.4	96	100	95.9	96.4	100	100	96.4
Heavy Vehicles	243	129	0	32	29	40	0	91	254	0	0	818
% Heavy Vehicles	4.5	3.7	0	2.1	1.6	4	0	4.1	3.6	0	0	3.6

Albeck Gerken, Inc

Transportation Engineers

Traffic Data Collection

I-94 at McKnight Rd, north ramps

File Name : 12 I-94 North Ramp & McKnight Rd

Site Code : 12

Start Date : 1/13/2012

Page No : 3

Ref.Pt.: 246.641

TURN MOVEMENT COUNT

Start Time	McKnight Rd Southbound				N Hudson Rd / ramp from I-94 WB Westbound					McKnight Rd Northbound				ramp to I-94 WB Eastbound		Int. Total
	Thru	Right	Peds	App. Total	Left	Thru	Right	Peds	App. Total	Left	Thru	Peds	App. Total	Peds	App. Total	
Peak Hour Analysis From 06:00 to 09:00 - Peak 1 of 1																
Peak Hour for Entire Intersection Begins at 08:00																
08:00	75	51	0	126	17	8	29	0	54	48	309	0	357	0	0	537
08:15	84	56	0	140	11	11	30	1	53	41	297	0	338	1	1	532
08:30	84	81	0	165	9	14	21	0	44	53	250	0	303	0	0	512
08:45	91	60	0	151	15	18	25	0	58	64	195	246	505	0	0	714
Total Volume	334	248	0	582	52	51	105	1	209	206	1051	246	1503	1	1	2295
% App. Total	57.4	42.6	0		24.9	24.4	50.2	0.5		13.7	69.9	16.4		100		
PHF	.918	.765	.000	.882	.765	.708	.875	.250	.901	.805	.850	.250	.744	.250	.250	.804

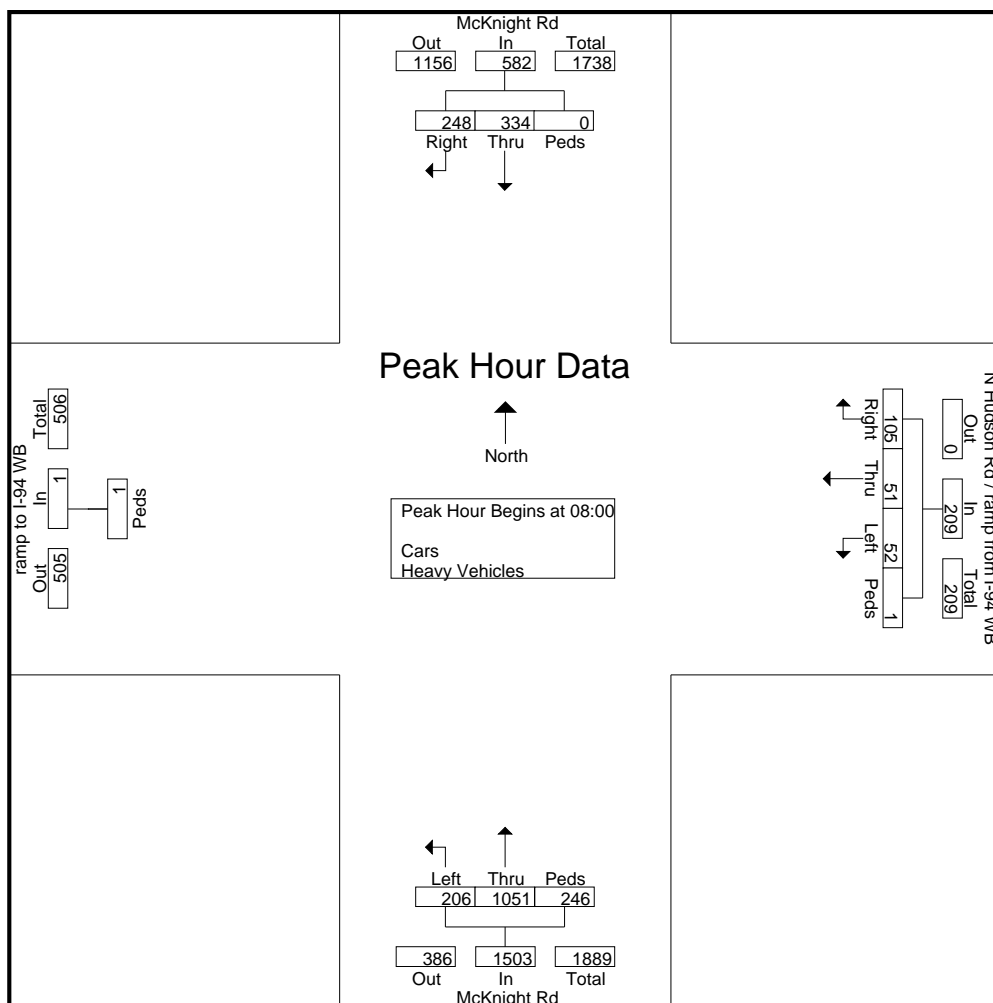

Albeck Gerken, Inc

Transportation Engineers

Traffic Data Collection

I-94 at McKnight Rd, north ramps

File Name : 12 I-94 North Ramp & McKnight Rd

Site Code : 12

Start Date : 1/13/2012

Ref.Pt.: 246.641

Page No : 4

TURN MOVEMENT COUNT

Start Time	McKnight Rd Southbound				N Hudson Rd / ramp from I-94 WB Westbound					McKnight Rd Northbound				ramp to I-94 WB Eastbound		Int. Total
	Thru	Right	Peds	App. Total	Left	Thru	Right	Peds	App. Total	Left	Thru	Peds	App. Total	Peds	App. Total	
Peak Hour Analysis From 15:00 to 18:45 - Peak 1 of 1																
Peak Hour for Entire Intersection Begins at 16:30																
16:30	188	121	0	309	96	68	38	0	202	56	152	0	208	1	1	720
16:45	195	119	0	314	92	73	24	0	189	45	148	0	193	1	1	697
17:00	203	133	0	336	79	76	22	0	177	44	133	0	177	1	1	691
17:15	187	104	0	291	79	82	42	0	203	46	128	0	174	0	0	668
Total Volume	773	477	0	1250	346	299	126	0	771	191	561	0	752	3	3	2776
% App. Total	61.8	38.2	0		44.9	38.8	16.3	0		25.4	74.6	0		100		
PHF	.952	.897	.000	.930	.901	.912	.750	.000	.950	.853	.923	.000	.904	.750	.750	.964

