

MN Dept of Transportation

TRAFFIC DATA COLLECTION - Metro

TH-100 at Benton Ave., East Ramps
 Ref.Pt.: 002.625
 video RE
 TURN MOVEMENT COUNT

File Name : TH-100 at Benton Ave EAST RAMPS 2015
 Site Code :
 Start Date : 1/14/2015
 Page No : 1

Groups Printed- Cars +

Start Time	Normandale Ave E / ramp to TH-100 NB Southbound				Normandale Ave E Northbound				Benton Ave Eastbound				Int. Total
	Left	Thru	Right	Peds	Left	Thru	Right	Peds	Left	Thru	Right	Peds	
06:00	0	1	1	0	4	5	0	0	11	0	7	0	29
06:15	0	1	1	0	8	14	0	0	19	0	11	0	54
06:30	0	2	3	0	4	11	0	0	20	0	25	0	65
06:45	0	3	5	0	10	18	0	0	33	0	26	0	95
Total	0	7	10	0	26	48	0	0	83	0	69	0	243
07:00	0	6	13	0	14	39	0	0	42	0	19	0	133
07:15	0	8	14	0	24	57	0	0	92	0	41	0	236
07:30	0	14	32	0	27	69	0	0	90	0	48	0	280
07:45	0	6	30	0	33	74	0	0	72	0	76	0	291
Total	0	34	89	0	98	239	0	0	296	0	184	0	940
08:00	0	4	29	0	56	52	0	0	58	0	58	0	257
08:15	0	22	17	0	34	66	0	0	83	0	64	0	286
08:30	0	9	16	0	29	46	0	0	57	0	45	0	202
08:45	0	5	11	0	35	32	0	0	46	0	37	0	166
Total	0	40	73	0	154	196	0	0	244	0	204	0	911
*****BREAK*****													
15:00	0	8	24	0	30	45	0	0	49	0	57	0	213
15:15	0	14	34	0	29	42	0	0	59	0	51	0	229
15:30	0	14	20	0	36	37	0	0	27	0	43	0	177
15:45	0	3	14	0	39	38	0	0	39	0	52	0	185
Total	0	39	92	0	134	162	0	0	174	0	203	0	804
16:00	0	8	12	0	40	45	0	0	48	0	50	0	203
16:15	0	17	24	0	42	46	0	0	32	0	83	0	244
16:30	0	9	19	0	42	48	0	0	52	0	86	0	256
16:45	0	6	9	0	43	47	0	0	49	0	73	0	227
Total	0	40	64	0	167	186	0	0	181	0	292	0	930
17:00	0	9	31	0	40	43	0	0	51	0	88	0	262
17:15	0	6	23	0	42	40	0	0	80	0	84	0	275
17:30	0	6	36	0	53	35	0	0	67	0	84	0	281
17:45	0	14	23	0	37	38	0	0	60	0	73	0	245
Total	0	35	113	0	172	156	0	0	258	0	329	0	1063
Grand Total	0	195	441	0	751	987	0	0	1236	0	1281	0	4891
Apprch %	0	30.7	69.3	0	43.2	56.8	0	0	49.1	0	50.9	0	
Total %	0	4	9	0	15.4	20.2	0	0	25.3	0	26.2	0	

MN Dept of Transportation

TRAFFIC DATA COLLECTION - Metro

TH-100 at Benton Ave., East Ramps
 Ref.Pt.: 002.625
 video RE
 TURN MOVEMENT COUNT

File Name : TH-100 at Benton Ave EAST RAMPS 2015
 Site Code :
 Start Date : 1/14/2015
 Page No : 2

Start Time	Normandale Ave E / ramp to TH-100 NB Southbound					Normandale Ave E Northbound					Benton Ave Eastbound					Int. Total
	Left	Thru	Right	Peds	App. Total	Left	Thru	Right	Peds	App. Total	Left	Thru	Right	Peds	App. Total	
Peak Hour Analysis From 06:00 to 08:45 - Peak 1 of 1																
Peak Hour for Entire Intersection Begins at 07:30																
07:30	0	14	32	0	46	27	69	0	0	96	90	0	48	0	138	280
07:45	0	6	30	0	36	33	74	0	0	107	72	0	76	0	148	291
08:00	0	4	29	0	33	56	52	0	0	108	58	0	58	0	116	257
08:15	0	22	17	0	39	34	66	0	0	100	83	0	64	0	147	286
Total Volume	0	46	108	0	154	150	261	0	0	411	303	0	246	0	549	1114
% App. Total	0	29.9	70.1	0		36.5	63.5	0	0		55.2	0	44.8	0		
PHF	.000	.523	.844	.000	.837	.670	.882	.000	.000	.951	.842	.000	.809	.000	.927	.957

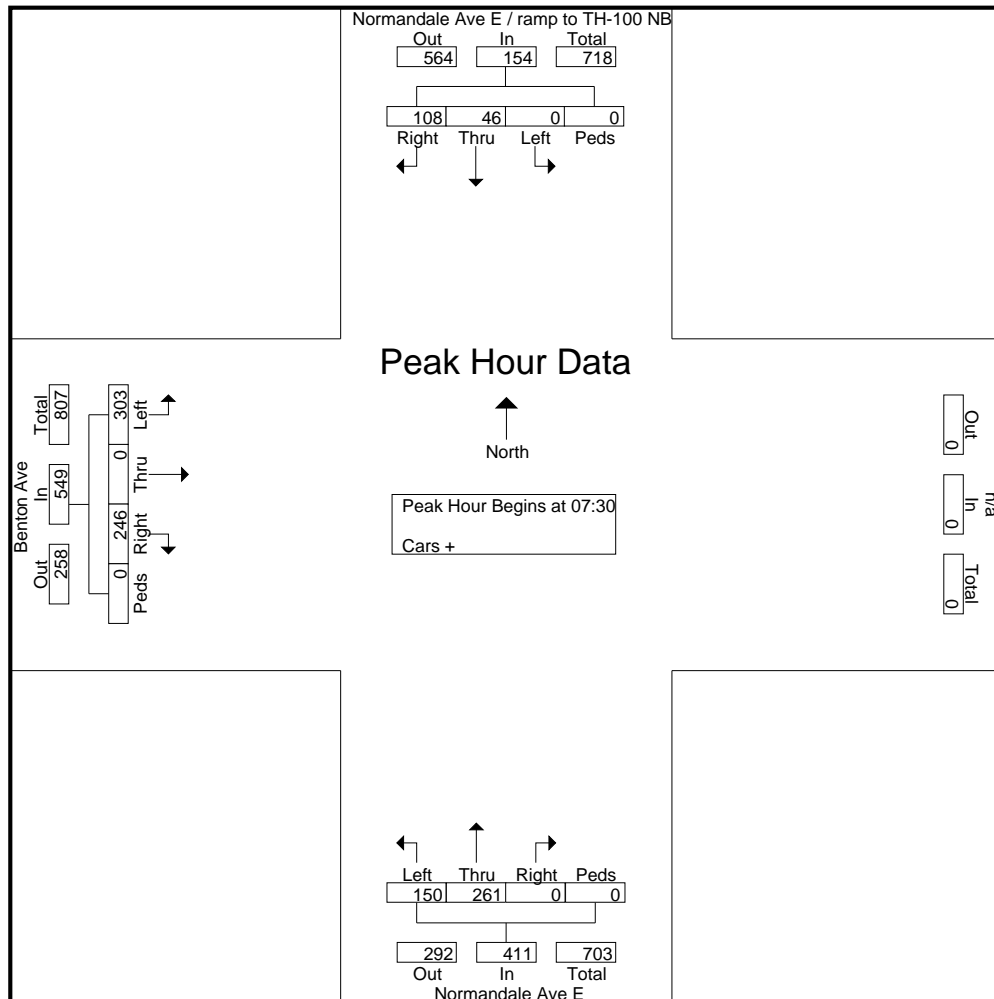

MN Dept of Transportation

TRAFFIC DATA COLLECTION - Metro

TH-100 at Benton Ave., East Ramps
 Ref.Pt.: 002.625
 video RE
 TURN MOVEMENT COUNT

File Name : TH-100 at Benton Ave EAST RAMPS 2015
 Site Code :
 Start Date : 1/14/2015
 Page No : 3

Start Time	Normandale Ave E / ramp to TH-100 NB Southbound					Normandale Ave E Northbound					Benton Ave Eastbound					Int. Total
	Left	Thru	Right	Peds	App. Total	Left	Thru	Right	Peds	App. Total	Left	Thru	Right	Peds	App. Total	
Peak Hour Analysis From 15:00 to 17:45 - Peak 1 of 1																
Peak Hour for Entire Intersection Begins at 17:00																
17:00	0	9	31	0	40	40	43	0	0	83	51	0	88	0	139	262
17:15	0	6	23	0	29	42	40	0	0	82	80	0	84	0	164	275
17:30	0	6	36	0	42	53	35	0	0	88	67	0	84	0	151	281
17:45	0	14	23	0	37	37	38	0	0	75	60	0	73	0	133	245
Total Volume	0	35	113	0	148	172	156	0	0	328	258	0	329	0	587	1063
% App. Total	0	23.6	76.4	0		52.4	47.6	0	0		44	0	56	0		
PHF	.000	.625	.785	.000	.881	.811	.907	.000	.000	.932	.806	.000	.935	.000	.895	.946

