

Alliant Engineering Inc Minneapolis, MN 55415

TH-101 at 141st Ave N - ROGERS
Ref.Pt.: 040.724
data by Alliant Engineering Inc
TURN MOVEMENT COUNT

File Name : TH-101 at 141st Ave N 2009
Site Code : 00000029
Start Date : 1/21/2009
Page No : 1

Groups Printed- Unshifted

Start Time	TH-101 Southbound				141st Ave N Westbound				TH-101 Northbound				141st Ave N Eastbound				Int. Total
	Left	Thru	Right	Peds	Left	Thru	Right	Peds	Left	Thru	Right	Peds	Left	Thru	Right	Peds	
06:00	39	503	7	0	8	6	12	0	0	53	6	0	1	9	7	0	651
06:15	53	521	27	0	11	15	5	0	2	69	9	0	4	19	9	0	744
06:30	55	489	25	0	8	12	15	0	9	72	9	0	12	29	1	0	736
06:45	120	474	16	0	9	6	12	0	21	74	20	0	7	30	2	0	791
Total	267	1987	75	0	36	39	44	0	32	268	44	0	24	87	19	0	2922
07:00	114	421	26	0	9	47	19	0	7	50	53	0	8	49	4	0	807
07:15	135	385	13	0	37	39	34	0	0	88	96	0	6	74	2	0	909
07:30	89	369	67	0	45	31	43	0	7	124	59	0	4	89	1	0	928
07:45	42	251	17	1	33	37	21	0	8	94	35	0	7	37	5	0	588
Total	380	1426	123	1	124	154	117	0	22	356	243	0	25	249	12	0	3232
08:00	59	291	13	0	13	8	13	0	5	65	17	0	4	22	2	0	512
08:15	37	284	16	0	12	11	9	0	5	99	13	0	7	16	4	0	513
08:30	29	273	18	0	20	9	7	0	5	62	18	0	7	15	3	0	466
08:45	37	242	29	0	22	26	9	0	3	75	23	0	14	21	10	0	511
Total	162	1090	76	0	67	54	38	0	18	301	71	0	32	74	19	0	2002
09:00	25	232	15	0	14	11	13	0	5	94	12	0	9	16	17	0	463
09:15	33	210	5	0	18	21	7	0	7	84	9	0	11	20	12	0	437
*** BREAK ***																	
Total	58	442	20	0	32	32	20	0	12	178	21	0	20	36	29	0	900
*** BREAK ***																	
10:30	15	159	4	0	19	11	9	0	3	107	23	1	9	10	8	0	378
10:45	24	197	10	0	15	13	18	0	15	91	15	0	6	7	19	0	430
Total	39	356	14	0	34	24	27	0	18	198	38	1	15	17	27	0	808
11:00	17	144	9	0	19	21	18	0	9	103	9	1	12	17	12	0	391
11:15	24	167	11	0	16	15	12	0	8	99	15	0	13	13	11	0	404
11:30	24	151	5	0	22	26	16	0	7	108	11	0	8	20	12	0	410
11:45	35	164	6	0	13	14	12	0	13	102	18	1	7	11	10	0	406
Total	100	626	31	0	70	76	58	0	37	412	53	2	40	61	45	0	1611
12:00	24	151	12	0	19	25	13	0	11	134	28	0	9	19	11	0	456
12:15	18	148	12	0	19	27	20	0	8	144	15	0	12	25	12	0	460
12:30	29	160	8	0	15	16	25	0	9	101	18	0	12	18	17	0	428
12:45	24	137	6	0	16	18	21	0	5	168	26	0	9	19	13	0	462
Total	95	596	38	0	69	86	79	0	33	547	87	0	42	81	53	0	1806
13:00	24	166	11	0	18	16	23	0	16	155	27	0	9	14	8	0	487
13:15	19	132	3	0	26	24	37	1	5	163	22	0	20	13	8	0	473
*** BREAK ***																	
Total	43	298	14	0	44	40	60	1	21	318	49	0	29	27	16	0	960
*** BREAK ***																	
14:30	32	163	9	0	31	25	41	0	6	178	19	0	24	32	10	1	571
14:45	28	151	17	1	28	29	35	0	7	294	15	0	17	32	14	0	668
Total	60	314	26	1	59	54	76	0	13	472	34	0	41	64	24	1	1239
15:00	17	85	13	0	23	44	39	1	10	292	27	0	34	32	13	0	630
15:15	33	162	13	0	24	38	47	1	17	347	34	0	18	17	8	0	759
15:30	30	164	14	1	35	37	56	0	16	379	25	0	40	43	28	0	868
15:45	35	138	10	0	21	28	85	2	23	461	35	0	25	30	9	0	902
Total	115	549	50	1	103	147	227	4	66	1479	121	0	117	122	58	0	3159

Alliant Engineering Inc Minneapolis, MN 55415

TH-101 at 141st Ave N - ROGERS
 Ref.Pt.: 040.724
 data by Alliant Engineering Inc
 TURN MOVEMENT COUNT

File Name : TH-101 at 141st Ave N 2009
 Site Code : 00000029
 Start Date : 1/21/2009
 Page No : 2

Groups Printed- Unshifted

Start Time	TH-101 Southbound				141st Ave N Westbound				TH-101 Northbound				141st Ave N Eastbound				Int. Total
	Left	Thru	Right	Peds	Left	Thru	Right	Peds	Left	Thru	Right	Peds	Left	Thru	Right	Peds	
16:00	29	158	7	0	21	49	80	0	25	391	20	0	34	43	13	0	870
16:15	39	156	12	0	31	42	58	2	16	393	18	0	22	25	19	0	833
16:30	28	154	10	0	31	32	74	0	24	493	27	0	36	38	13	0	960
16:45	37	189	8	0	24	38	77	0	16	477	18	0	19	31	5	0	939
Total	133	657	37	0	107	161	289	2	81	1754	83	0	111	137	50	0	3602
17:00	29	140	11	0	43	60	97	0	12	403	28	0	21	54	23	0	921
17:15	44	177	11	0	23	46	94	0	18	515	22	0	30	24	24	0	1028
17:30	34	169	14	0	46	60	59	0	10	398	31	0	29	21	16	0	887
17:45	33	141	10	0	27	37	48	0	18	363	23	0	14	28	8	0	750
Total	140	627	46	0	139	203	298	0	58	1679	104	0	94	127	71	0	3586
Grand Total	1592	8968	550	3	884	1070	1333	7	411	7962	948	3	590	1082	423	1	25827
Apprch %	14.3	80.7	4.9	0	26.8	32.5	40.5	0.2	4.4	85.4	10.2	0	28.1	51.6	20.2	0	
Total %	6.2	34.7	2.1	0	3.4	4.1	5.2	0	1.6	30.8	3.7	0	2.3	4.2	1.6	0	

Alliant Engineering Inc Minneapolis, MN 55415

TH-101 at 141st Ave N - ROGERS
 Ref.Pt.: 040.724
 data by Alliant Engineering Inc
 TURN MOVEMENT COUNT

File Name : TH-101 at 141st Ave N 2009
 Site Code : 00000029
 Start Date : 1/21/2009
 Page No : 3

Start Time	TH-101 Southbound					141st Ave N Westbound					TH-101 Northbound					141st Ave N Eastbound					Int. Total
	Left	Thru	Right	Peds	App. Total	Left	Thru	Right	Peds	App. Total	Left	Thru	Right	Peds	App. Total	Left	Thru	Right	Peds	App. Total	
Peak Hour Analysis From 06:00 to 08:45 - Peak 1 of 1																					
Peak Hour for Entire Intersection Begins at 06:45																					
06:45	120	474	16	0	610	9	6	12	0	27	21	74	20	0	115	7	30	2	0	39	791
07:00	114	421	26	0	561	9	47	19	0	75	7	50	53	0	110	8	49	4	0	61	807
07:15	135	385	13	0	533	37	39	34	0	110	0	88	96	0	184	6	74	2	0	82	909
07:30	89	369	67	0	525	45	31	43	0	119	7	124	59	0	190	4	89	1	0	94	928
Total Volume	458	1649	122	0	2229	100	123	108	0	331	35	336	228	0	599	25	242	9	0	276	3435
% App. Total	20.5	74	5.5	0		30.2	37.2	32.6	0		5.8	56.1	38.1	0		9.1	87.7	3.3	0		
PHF	.848	.870	.455	.000	.914	.556	.654	.628	.000	.695	.417	.677	.594	.000	.788	.781	.680	.563	.000	.734	.925

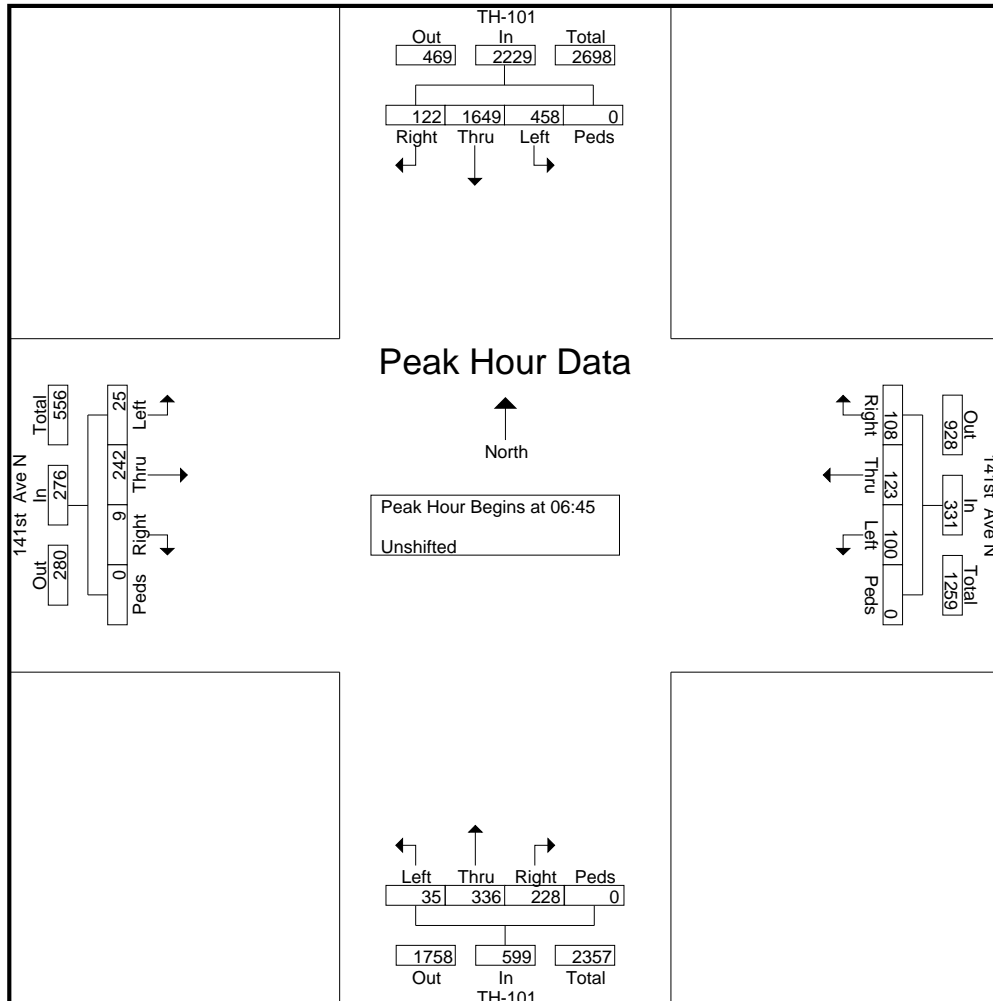

Alliant Engineering Inc Minneapolis, MN 55415

TH-101 at 141st Ave N - ROGERS
 Ref.Pt.: 040.724
 data by Alliant Engineering Inc
 TURN MOVEMENT COUNT

File Name : TH-101 at 141st Ave N 2009
 Site Code : 00000029
 Start Date : 1/21/2009
 Page No : 4

Start Time	TH-101 Southbound					141st Ave N Westbound					TH-101 Northbound					141st Ave N Eastbound					Int. Total
	Left	Thru	Right	Peds	App. Total	Left	Thru	Right	Peds	App. Total	Left	Thru	Right	Peds	App. Total	Left	Thru	Right	Peds	App. Total	
Peak Hour Analysis From 15:00 to 17:45 - Peak 1 of 1																					
Peak Hour for Entire Intersection Begins at 16:30																					
16:30	28	154	10	0	192	31	32	74	0	137	24	493	27	0	544	36	38	13	0	87	960
16:45	37	189	8	0	234	24	38	77	0	139	16	477	18	0	511	19	31	5	0	55	939
17:00	29	140	11	0	180	43	60	97	0	200	12	403	28	0	443	21	54	23	0	98	921
17:15	44	177	11	0	232	23	46	94	0	163	18	515	22	0	555	30	24	24	0	78	1028
Total Volume	138	660	40	0	838	121	176	342	0	639	70	1888	95	0	2053	106	147	65	0	318	3848
% App. Total	16.5	78.8	4.8	0		18.9	27.5	53.5	0		3.4	92	4.6	0		33.3	46.2	20.4	0		
PHF	.784	.873	.909	.000	.895	.703	.733	.881	.000	.799	.729	.917	.848	.000	.925	.736	.681	.677	.000	.811	.936

