



MINNESOTA DEPT OF TRANSPORTATION

TRAFFIC DATA COLLECTION - METRO

TH -120 AT JOY RD & HADLEY AVE
 Ref.Pt.: 007.944
 JAMAR# 632 DR
 TURN MOVEMENT COUNT

File Name : TH 120 AT JOY RD AND HADLEY AVE 2008
 Site Code : 00000000
 Start Date : 9/25/2008
 Page No : 1

Groups Printed- Unshifted

Start Time	TH-120 Southbound				HADLEY AVE Westbound				TH-120 Northbound				JOY RD Eastbound				Int. Total
	Left	Thru	Right	Peds	Left	Thru	Right	Peds	Left	Thru	Right	Peds	Left	Thru	Right	Peds	
06:00	2	34	1	0	1	2	9	0	2	36	0	0	12	0	4	0	103
06:15	12	49	3	0	1	3	11	0	3	54	1	0	16	1	1	0	155
06:30	17	62	7	0	3	1	18	0	2	69	1	0	13	2	2	0	197
06:45	13	81	4	0	2	6	18	0	2	83	1	0	14	4	2	0	230
Total	44	226	15	0	7	12	56	0	9	242	3	0	55	7	9	0	685
07:00	18	81	7	0	4	8	32	0	2	96	5	0	16	4	2	0	275
07:15	22	63	8	0	4	6	41	0	7	112	3	0	17	6	1	0	290
07:30	17	84	5	0	7	6	55	0	6	152	1	0	27	4	5	0	369
07:45	35	87	11	0	8	9	40	0	3	102	4	0	28	5	4	0	336
Total	92	315	31	0	23	29	168	0	18	462	13	0	88	19	12	0	1270
08:00	22	74	5	0	3	5	22	0	3	89	3	0	22	5	3	0	256
08:15	11	56	10	0	1	4	34	0	3	89	6	0	9	2	4	0	229
08:30	22	62	5	0	4	7	29	0	7	100	4	0	12	7	5	0	264
08:45	26	66	7	0	3	6	30	0	4	99	4	0	15	3	4	0	267
Total	81	258	27	0	11	22	115	0	17	377	17	0	58	17	16	0	1016
*** BREAK ***																	
15:00	47	91	16	0	1	14	36	0	7	98	6	0	15	8	17	0	356
15:15	25	108	22	0	4	9	48	0	12	120	6	0	17	15	12	0	398
15:30	27	97	20	0	5	12	44	0	12	117	8	0	30	11	5	0	388
15:45	36	101	21	0	3	16	42	0	9	130	13	0	16	14	6	0	407
Total	135	397	79	0	13	51	170	0	40	465	33	0	78	48	40	0	1549
16:00	42	90	27	0	0	12	45	0	12	96	15	0	12	14	9	0	374
16:15	36	114	27	0	3	11	39	0	10	113	3	0	18	8	7	0	389
16:30	59	79	26	0	4	15	34	0	5	101	10	0	19	12	4	0	368
16:45	47	105	25	0	2	21	49	0	8	130	7	0	15	11	10	0	430
Total	184	388	105	0	9	59	167	0	35	440	35	0	64	45	30	0	1561
17:00	58	85	25	0	3	17	48	0	9	134	7	0	23	20	15	0	444
17:15	49	124	21	0	4	14	52	0	6	131	10	0	20	29	14	0	474
17:30	46	89	24	0	7	6	46	0	10	148	5	0	29	19	5	0	434
17:45	52	98	27	0	5	12	43	0	10	131	8	0	37	17	9	0	449
Total	205	396	97	0	19	49	189	0	35	544	30	0	109	85	43	0	1801
Grand Total	741	1980	354	0	82	222	865	0	154	2530	131	0	452	221	150	0	7882
Apprch %	24.1	64.4	11.5	0	7	19	74	0	5.5	89.9	4.7	0	54.9	26.9	18.2	0	
Total %	9.4	25.1	4.5	0	1	2.8	11	0	2	32.1	1.7	0	5.7	2.8	1.9	0	



MINNESOTA DEPT OF TRANSPORTATION

TRAFFIC DATA COLLECTION - METRO

TH -120 AT JOY RD & HADLEY AVE
 Ref.Pt.: 007.944
 JAMAR# 632 DR
 TURN MOVEMENT COUNT

File Name : TH 120 AT JOY RD AND HADLEY AVE 2008
 Site Code : 00000000
 Start Date : 9/25/2008
 Page No : 2

Start Time	TH-120 Southbound					HADLEY AVE Westbound					TH-120 Northbound					JOY RD Eastbound					Int. Total
	Left	Thru	Right	Peds	App. Total	Left	Thru	Right	Peds	App. Total	Left	Thru	Right	Peds	App. Total	Left	Thru	Right	Peds	App. Total	
Peak Hour Analysis From 06:00 to 08:45 - Peak 1 of 1																					
Peak Hour for Entire Intersection Begins at 07:00																					
07:00	18	81	7	0	106	4	8	32	0	44	2	96	5	0	103	16	4	2	0	22	275
07:15	22	63	8	0	93	4	6	41	0	51	7	112	3	0	122	17	6	1	0	24	290
07:30	17	84	5	0	106	7	6	55	0	68	6	152	1	0	159	27	4	5	0	36	369
07:45	35	87	11	0	133	8	9	40	0	57	3	102	4	0	109	28	5	4	0	37	336
Total Volume	92	315	31	0	438	23	29	168	0	220	18	462	13	0	493	88	19	12	0	119	1270
% App. Total																					
PHF	.657	.905	.705	.000	.823	.719	.806	.764	.000	.809	.643	.760	.650	.000	.775	.786	.792	.600	.000	.804	.860

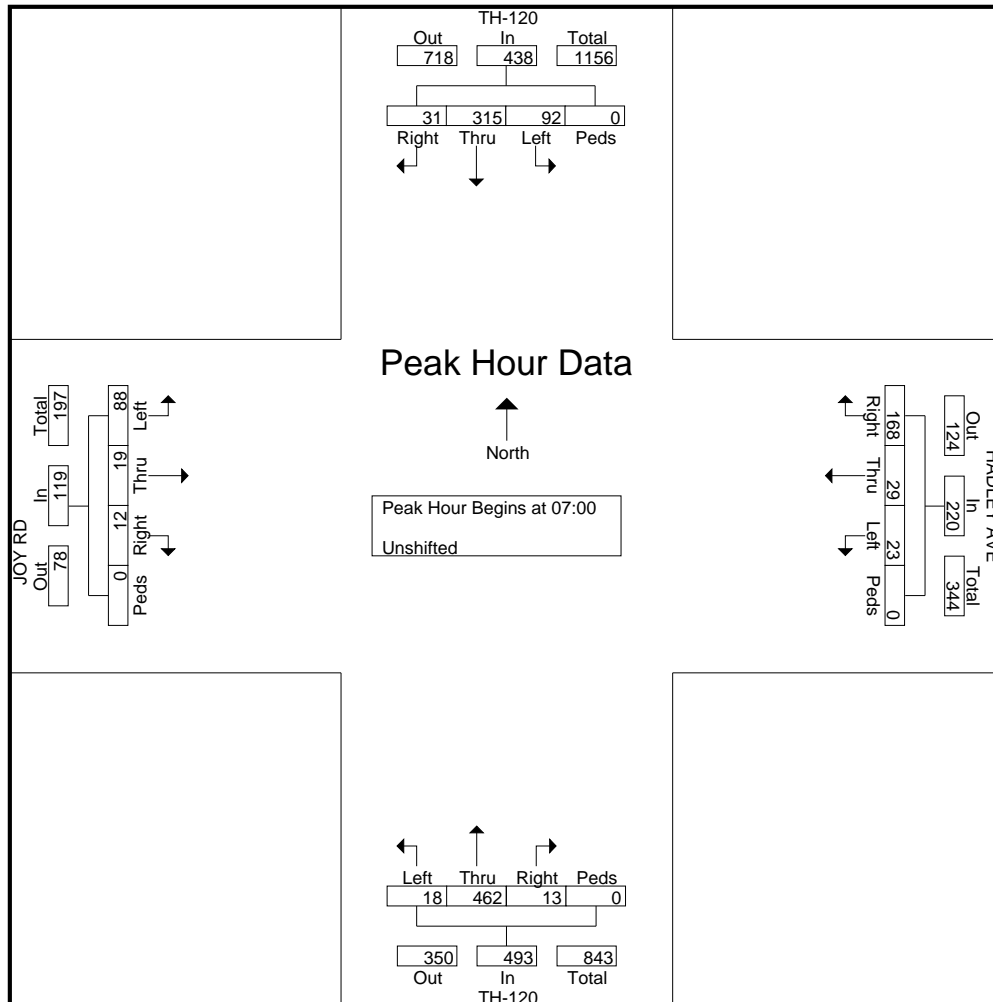



MINNESOTA DEPT OF TRANSPORTATION

TRAFFIC DATA COLLECTION - METRO

TH -120 AT JOY RD & HADLEY AVE
 Ref.Pt.: 007.944
 JAMAR# 632 DR
 TURN MOVEMENT COUNT

File Name : TH 120 AT JOY RD AND HADLEY AVE 2008
 Site Code : 00000000
 Start Date : 9/25/2008
 Page No : 3

Start Time	TH-120 Southbound					HADLEY AVE Westbound					TH-120 Northbound					JOY RD Eastbound					Int. Total
	Left	Thru	Right	Peds	App. Total	Left	Thru	Right	Peds	App. Total	Left	Thru	Right	Peds	App. Total	Left	Thru	Right	Peds	App. Total	
Peak Hour Analysis From 16:00 to 17:45 - Peak 1 of 1																					
Peak Hour for Entire Intersection Begins at 17:00																					
17:00	58	85	25	0	168	3	17	48	0	68	9	134	7	0	150	23	20	15	0	58	444
17:15	49	124	21	0	194	4	14	52	0	70	6	131	10	0	147	20	29	14	0	63	474
17:30	46	89	24	0	159	7	6	46	0	59	10	148	5	0	163	29	19	5	0	53	434
17:45	52	98	27	0	177	5	12	43	0	60	10	131	8	0	149	37	17	9	0	63	449
Total Volume	205	396	97	0	698	19	49	189	0	257	35	544	30	0	609	109	85	43	0	237	1801
% App. Total																					
PHF	.884	.798	.898	.000	.899	.679	.721	.909	.000	.918	.875	.919	.750	.000	.934	.736	.733	.717	.000	.940	.950

