

# Alliant Engineering

Minneapolis, MN 55415

--TRAFFIC DATA --

TH-13 at Mendota Heights Rd.

File Name : 101 - TH 13 & Mendota Heights Rd

Site Code : 101

BY :Alliant Eng.

Start Date : 12/3/2014

TURN MOVEMENT COUNT

Page No : 1

Groups Printed- Cars - Trucks

Start Time	TH 13 Southbound				Mendota Heights Rd Westbound				TH 13 Northbound				Mendota Heights Rd Eastbound				Int. Total
	Left	Thru	Rght	Bikes	Left	Thru	Rght	Bikes	Left	Thru	Rght	Bikes	Left	Thru	Rght	Bikes	
06:00	1	10	1	0	8	2	0	0	9	16	11	0	0	3	6	0	67
06:15	1	10	0	0	7	2	6	0	10	50	10	0	0	2	9	0	107
06:30	2	17	3	0	13	0	0	0	19	57	26	0	1	4	17	0	159
06:45	1	19	0	0	8	1	0	0	16	63	31	0	0	6	10	0	155
Total	5	56	4	0	36	5	6	0	54	186	78	0	1	15	42	0	488
07:00	0	24	0	0	13	0	0	0	16	81	25	0	0	1	14	0	174
07:15	1	18	0	0	12	1	0	0	41	95	33	0	0	5	12	0	218
07:30	1	39	1	0	21	0	1	0	54	139	46	0	1	5	19	0	327
07:45	5	44	0	0	18	3	1	0	25	127	54	0	0	7	26	0	310
Total	7	125	1	0	64	4	2	0	136	442	158	0	1	18	71	0	1029
08:00	4	37	0	0	20	0	4	0	33	92	41	0	1	6	10	1	249
08:15	2	47	3	0	6	4	0	0	17	83	33	0	1	4	19	0	219
08:30	0	39	1	0	17	2	0	0	17	55	23	0	0	1	13	0	168
08:45	3	51	0	0	10	1	0	0	19	56	15	0	0	1	8	0	164
Total	9	174	4	0	53	7	4	0	86	286	112	0	2	12	50	1	800
09:00	3	30	0	0	8	3	1	0	13	45	16	0	0	2	9	0	130
09:15	3	24	0	0	13	2	1	0	8	39	8	0	2	2	10	0	112
09:30	0	0	0	0	0	0	0	0	0	0	1	0	0	0	0	0	1
*** BREAK ***																	
Total	6	54	0	0	21	5	2	0	21	84	25	0	2	4	19	0	243
*** BREAK ***																	
10:30	0	14	2	0	2	2	1	0	6	32	12	0	0	2	8	0	81
10:45	0	29	0	0	9	3	3	0	6	30	22	0	1	1	6	0	110
Total	0	43	2	0	11	5	4	0	12	62	34	0	1	3	14	0	191
11:00	4	19	0	0	7	4	2	0	9	29	17	0	1	1	5	0	98
11:15	5	28	1	0	11	1	3	0	10	33	10	0	0	4	11	0	117
11:30	0	22	1	0	14	6	3	0	13	37	7	0	1	6	11	0	121
11:45	2	34	0	0	11	5	1	1	7	42	7	0	4	1	9	0	124
Total	11	103	2	0	43	16	9	1	39	141	41	0	6	12	36	0	460
12:00	2	33	1	0	11	4	1	0	10	31	12	0	1	3	8	0	117
12:15	4	35	3	0	12	8	1	0	8	31	5	0	0	5	8	0	120
12:30	3	27	2	0	15	3	2	0	8	40	22	0	1	9	10	0	142
12:45	1	31	1	0	7	5	0	0	6	30	16	0	0	3	9	0	109
Total	10	126	7	0	45	20	4	0	32	132	55	0	2	20	35	0	488
13:00	1	33	1	0	13	6	1	0	4	29	15	0	0	13	11	0	127
13:15	1	34	2	0	11	5	0	0	9	27	14	0	2	11	13	0	129
13:30	0	0	0	0	2	0	0	0	1	0	1	0	0	0	0	0	4
*** BREAK ***																	
Total	2	67	3	0	26	11	1	0	14	56	30	0	2	24	24	0	260
*** BREAK ***																	
14:30	3	48	0	0	22	5	4	0	8	54	16	0	0	3	7	0	170
14:45	0	28	0	0	20	3	2	0	14	51	22	0	0	1	10	0	151
Total	3	76	0	0	42	8	6	0	22	105	38	0	0	4	17	0	321
15:00	2	43	3	0	22	1	4	0	5	43	18	0	0	4	12	0	157
15:15	2	54	0	0	15	2	1	0	14	40	15	0	0	6	14	0	163
15:30	0	60	2	0	44	8	8	0	19	54	23	0	1	10	16	0	245
15:45	2	55	1	0	18	3	2	0	5	49	12	0	0	5	17	0	169
Total	6	212	6	0	99	14	15	0	43	186	68	0	1	25	59	0	734
16:00	0	73	0	0	25	1	2	0	7	54	21	0	1	6	21	0	211

# Alliant Engineering

Minneapolis, MN 55415

--TRAFFIC DATA --

TH-13 at Mendota Heights Rd.

File Name : 101 - TH 13 & Mendota Heights Rd

Site Code : 101

BY :Alliant Eng.

Start Date : 12/3/2014

TURN MOVEMENT COUNT

Page No : 2

Groups Printed- Cars - Trucks

Start Time	TH 13 Southbound				Mendota Heights Rd Westbound				TH 13 Northbound				Mendota Heights Rd Eastbound				Int. Total
	Left	Thru	Rght	Bikes	Left	Thru	Rght	Bikes	Left	Thru	Rght	Bikes	Left	Thru	Rght	Bikes	
16:15	2	88	0	0	33	2	0	0	23	58	10	0	0	5	34	0	255
16:30	0	103	0	0	36	1	6	0	13	64	18	0	1	7	30	0	279
16:45	1	137	0	0	29	2	3	0	19	86	20	0	0	6	35	0	338
Total	3	401	0	0	123	6	11	0	62	262	69	0	2	24	120	0	1083
17:00	1	100	0	0	51	7	6	0	13	70	12	0	0	6	56	0	322
17:15	0	90	0	0	56	11	1	0	14	61	20	0	0	15	24	0	292
17:30	0	83	2	0	35	7	1	0	12	50	13	0	5	7	16	0	231
17:45	0	69	0	0	21	9	3	0	10	67	10	0	0	0	27	0	216
Total	1	342	2	0	163	34	11	0	49	248	55	0	5	28	123	0	1061
18:00	0	24	3	0	1	2	13	0	8	39	8	0	10	2	2	0	112
Grand Total	63	1803	34	0	727	137	88	1	578	2229	771	0	35	191	612	1	7270
Apprch %	3.3	94.9	1.8	0	76.3	14.4	9.2	0.1	16.2	62.3	21.5	0	4.2	22.8	72.9	0.1	
Total %	0.9	24.8	0.5	0	10	1.9	1.2	0	8	30.7	10.6	0	0.5	2.6	8.4	0	
Cars	57	1712	26	0	659	127	82	0	567	2138	713	0	27	169	605	1	6883
% Cars	90.5	95	76.5	0	90.6	92.7	93.2	0	98.1	95.9	92.5	0	77.1	88.5	98.9	100	94.7
Trucks	6	91	8	0	68	10	6	1	11	91	58	0	8	22	7	0	387
% Trucks	9.5	5	23.5	0	9.4	7.3	6.8	100	1.9	4.1	7.5	0	22.9	11.5	1.1	0	5.3

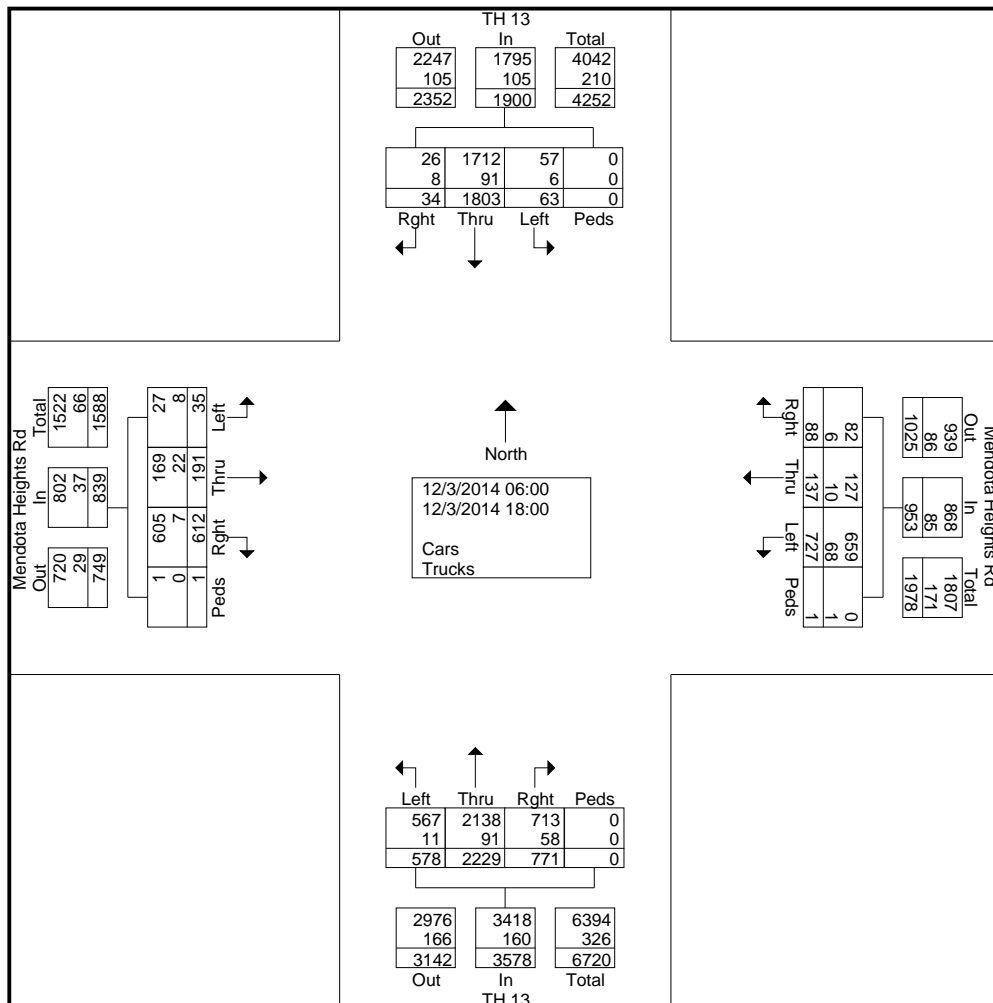

# Alliant Engineering

Minneapolis, MN 55415

--TRAFFIC DATA --

TH-13 at Mendota Heights Rd.

File Name : 101 - TH 13 & Mendota Heights Rd

Site Code : 101

BY :Alliant Eng.

Start Date : 12/3/2014

TURN MOVEMENT COUNT

Page No : 3

Start Time	TH 13 Southbound					Mendota Heights Rd Westbound					TH 13 Northbound					Mendota Heights Rd Eastbound					Int. Total
	Left	Thru	Rght	Bikes	App. Total	Left	Thru	Rght	Bikes	App. Total	Left	Thru	Rght	Bikes	App. Total	Left	Thru	Rght	Bikes	App. Total	
Peak Hour Analysis From 06:00 to 11:45 - Peak 1 of 1																					
Peak Hour for Entire Intersection Begins at 07:30																					
07:30	1	39	1	0	41	21	0	1	0	22	54	139	46	0	239	1	5	19	0	25	327
07:45	5	44	0	0	49	18	3	1	0	22	25	127	54	0	206	0	7	26	0	33	310
08:00	4	37	0	0	41	20	0	4	0	24	33	92	41	0	166	1	6	10	1	18	249
08:15	2	47	3	0	52	6	4	0	0	10	17	83	33	0	133	1	4	19	0	24	219
Total Volume	12	167	4	0	183	65	7	6	0	78	129	441	174	0	744	3	22	74	1	100	1105
% App. Total	6.6	91.3	2.2	0		83.3	9	7.7	0		17.3	59.3	23.4	0		3	22	74	1		
PHF	.600	.888	.333	.000	.880	.774	.438	.375	.000	.813	.597	.793	.806	.000	.778	.750	.786	.712	.250	.758	.845

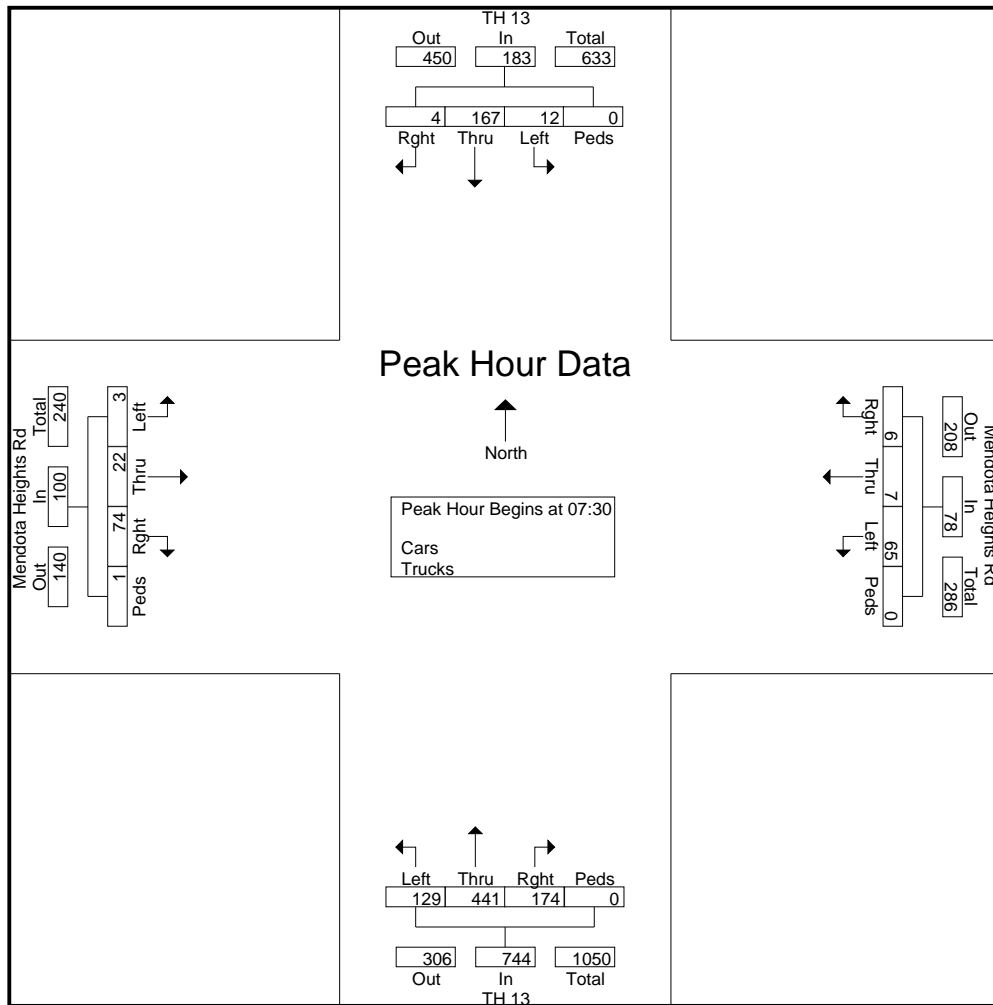

# Alliant Engineering

Minneapolis, MN 55415

--TRAFFIC DATA --

TH-13 at Mendota Heights Rd.

File Name : 101 - TH 13 & Mendota Heights Rd

Site Code : 101

BY :Alliant Eng.

Start Date : 12/3/2014

TURN MOVEMENT COUNT

Page No : 4

Start Time	TH 13 Southbound					Mendota Heights Rd Westbound					TH 13 Northbound					Mendota Heights Rd Eastbound					Int. Total
	Left	Thru	Rght	Bikes	App. Total	Left	Thru	Rght	Bikes	App. Total	Left	Thru	Rght	Bikes	App. Total	Left	Thru	Rght	Bikes	App. Total	
Peak Hour Analysis From 12:00 to 18:00 - Peak 1 of 1																					
Peak Hour for Entire Intersection Begins at 16:30																					
16:30	0	103	0	0	103	36	1	6	0	43	13	64	18	0	95	1	7	30	0	38	279
16:45	1	137	0	0	138	29	2	3	0	34	19	86	20	0	125	0	6	35	0	41	338
17:00	1	100	0	0	101	51	7	6	0	64	13	70	12	0	95	0	6	56	0	62	322
17:15	0	90	0	0	90	56	11	1	0	68	14	61	20	0	95	0	15	24	0	39	292
Total Volume	2	430	0	0	432	172	21	16	0	209	59	281	70	0	410	1	34	145	0	180	1231
% App. Total	0.5	99.5	0	0		82.3	10	7.7	0		14.4	68.5	17.1	0		0.6	18.9	80.6	0		
PHF	.500	.785	.000	.000	.783	.768	.477	.667	.000	.768	.776	.817	.875	.000	.820	.250	.567	.647	.000	.726	.911

