



# MINNESOTA DEPT OF TRANSPORTATION

## TRAFFIC DATA COLLECTION - METRO

MN-280 AT W Co.Rd.B / CSAH-25  
 REF.PT.: 003.317  
 DATA COLLECTED BY TDI  
 TURN MOVEMENT COUNT

File Name : TH-280 AT Co Rd B 2007  
 Site Code : 00198741  
 Start Date : 6/5/2007  
 Page No : 1

### Groups Printed- Unshifted

Start Time	MN-280 Southbound				Co.Rd.B Westbound				MN-280 Northbound				City Street Eastbound				Int. Total
	Left	Thru	Right	Peds	Left	Thru	Right	Peds	Left	Thru	Right	Peds	Left	Thru	Right	Peds	
06:00	0	376	2	0	3	0	0	0	2	97	1	0	1	0	0	0	482
06:15	0	462	7	0	3	0	1	0	3	143	3	0	0	0	2	0	624
06:30	0	517	8	0	7	0	0	0	4	199	3	2	1	0	0	0	741
06:45	2	530	14	0	20	1	2	0	1	265	5	0	1	0	1	0	842
Total	2	1885	31	0	33	1	3	0	10	704	12	2	3	0	3	0	2689
07:00	0	495	7	0	16	0	1	0	8	285	5	0	0	0	1	0	818
07:15	1	499	5	0	29	0	4	0	7	308	3	0	1	0	3	0	860
07:30	0	460	11	0	38	1	1	0	0	337	9	0	0	0	3	0	860
07:45	1	423	5	0	35	2	2	0	3	329	4	0	2	4	2	0	812
Total	2	1877	28	0	118	3	8	0	18	1259	21	0	3	4	9	0	3350
08:00	0	427	6	0	29	0	3	0	5	285	4	0	0	1	1	0	761
08:15	5	446	13	0	35	0	1	0	5	267	8	0	1	3	5	0	789
08:30	1	492	5	0	30	0	2	0	7	253	9	0	2	1	4	0	806
08:45	4	398	3	0	24	1	5	0	6	253	12	0	4	1	2	0	713
Total	10	1763	27	0	118	1	11	0	23	1058	33	0	7	6	12	0	3069
*** BREAK ***																	
11:00	0	243	2	0	5	0	1	0	3	277	13	0	3	0	3	0	550
11:15	3	278	6	0	13	0	0	0	6	266	10	0	8	0	5	0	595
11:30	6	276	4	0	6	1	2	0	3	295	18	0	5	0	4	0	620
11:45	5	273	5	0	17	0	5	0	4	304	14	0	4	0	1	0	632
Total	14	1070	17	0	41	1	8	0	16	1142	55	0	20	0	13	0	2397
12:00	4	224	6	1	24	1	5	0	4	331	17	0	4	2	9	1	633
12:15	4	352	5	0	16	4	2	0	3	306	14	0	2	0	2	0	710
12:30	2	299	2	0	12	0	2	0	4	275	17	0	1	2	2	0	618
12:45	2	305	5	0	22	1	5	0	5	308	18	0	4	4	2	0	681
Total	12	1180	18	1	74	6	14	0	16	1220	66	0	11	8	15	1	2642
*** BREAK ***																	
15:00	1	278	9	1	15	0	1	0	0	579	26	0	6	1	0	0	917
15:15	3	301	0	0	6	1	3	0	5	524	29	0	6	1	1	0	880
15:30	1	320	9	0	12	2	0	0	0	567	41	0	12	4	2	0	970
15:45	5	306	2	0	14	0	1	0	0	490	25	0	7	1	0	0	851
Total	10	1205	20	1	47	3	5	0	5	2160	121	0	31	7	3	0	3618
16:00	8	322	4	0	17	1	3	0	2	526	28	0	15	1	2	1	930
16:15	5	332	2	0	10	0	2	0	4	530	45	1	7	1	0	0	939
16:30	8	372	2	0	17	0	2	0	0	573	43	0	13	3	4	0	1037
16:45	2	370	3	0	15	0	2	0	4	539	67	0	4	1	1	0	1008
Total	23	1396	11	0	59	1	9	0	10	2168	183	1	39	6	7	1	3914
17:00	1	429	2	0	16	0	1	0	1	532	57	0	6	0	5	0	1050
17:15	3	372	1	0	15	1	5	0	2	477	57	0	1	0	2	0	936
17:30	4	368	1	0	11	0	3	0	3	469	45	0	2	1	4	0	911
17:45	2	273	2	0	15	0	3	0	3	432	39	0	3	0	1	0	773
Total	10	1442	6	0	57	1	12	0	9	1910	198	0	12	1	12	0	3670



# MINNESOTA DEPT OF TRANSPORTATION

## TRAFFIC DATA COLLECTION - METRO

MN-280 AT W Co.Rd.B / CSAH-25  
 REF.PT.: 003.317  
 DATA COLLECTED BY TDI  
 TURN MOVEMENT COUNT

File Name : TH-280 AT Co Rd B 2007  
 Site Code : 00198741  
 Start Date : 6/5/2007  
 Page No : 2

### Groups Printed- Unshifted

	MN-280 Southbound				Co.Rd.B Westbound				MN-280 Northbound				City Street Eastbound				Int. Total
	Left	Thru	Right	Peds	Left	Thru	Right	Peds	Left	Thru	Right	Peds	Left	Thru	Right	Peds	
Grand Total	83	11818	158	2	547	17	70	0	107	11621	689	3	126	32	74	2	25349
Apprch %	0.7	98	1.3	0	86.3	2.7	11	0	0.9	93.6	5.5	0	53.8	13.7	31.6	0.9	
Total %	0.3	46.6	0.6	0	2.2	0.1	0.3	0	0.4	45.8	2.7	0	0.5	0.1	0.3	0	



# MINNESOTA DEPT OF TRANSPORTATION

## TRAFFIC DATA COLLECTION - METRO

MN-280 AT W Co.Rd.B / CSAH-25  
 REF.PT.: 003.317  
 DATA COLLECTED BY TDI  
 TURN MOVEMENT COUNT

File Name : TH-280 AT Co Rd B 2007  
 Site Code : 00198741  
 Start Date : 6/5/2007  
 Page No : 3

Start Time	MN-280 Southbound					Co.Rd.B Westbound					MN-280 Northbound					City Street Eastbound					Int. Total
	Left	Thru	Right	Peds	App. Total	Left	Thru	Right	Peds	App. Total	Left	Thru	Right	Peds	App. Total	Left	Thru	Right	Peds	App. Total	
Peak Hour Analysis From 06:00 to 08:45 - Peak 1 of 1																					
Peak Hour for Entire Intersection Begins at 06:45																					
06:45	2	530	14	0	546	20	1	2	0	23	1	265	5	0	271	1	0	1	0	2	842
07:00	0	495	7	0	502	16	0	1	0	17	8	285	5	0	298	0	0	1	0	1	818
07:15	1	499	5	0	505	29	0	4	0	33	7	308	3	0	318	1	0	3	0	4	860
07:30	0	460	11	0	471	38	1	1	0	40	0	337	9	0	346	0	0	3	0	3	860
Total Volume	3	1984	37	0	2024	103	2	8	0	113	16	1195	22	0	1233	2	0	8	0	10	3380
% App. Total	0.1	98	1.8	0		91.2	1.8	7.1	0		1.3	96.9	1.8	0		20	0	80	0		
PHF	.375	.936	.661	.000	.927	.678	.500	.500	.000	.706	.500	.886	.611	.000	.891	.500	.000	.667	.000	.625	.983

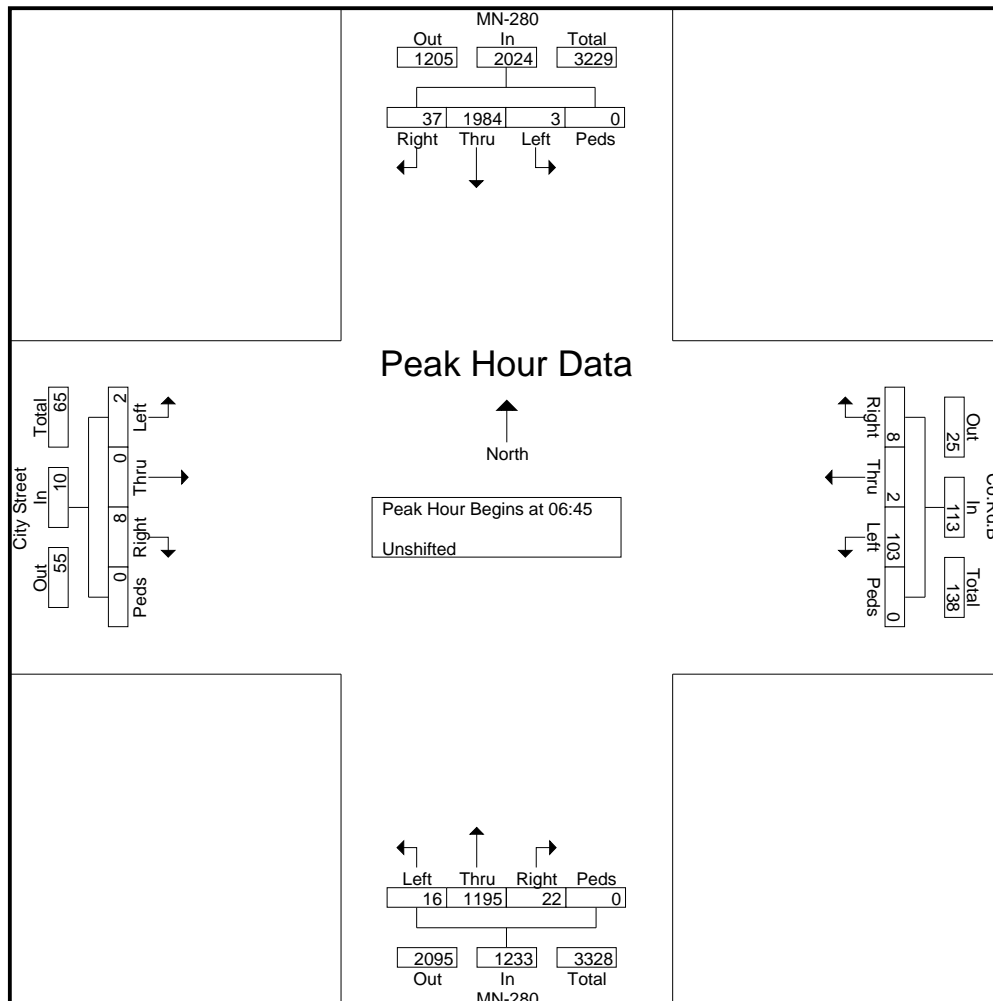



# MINNESOTA DEPT OF TRANSPORTATION

## TRAFFIC DATA COLLECTION - METRO

MN-280 AT W Co.Rd.B / CSAH-25  
 REF.PT.: 003.317  
 DATA COLLECTED BY TDI  
 TURN MOVEMENT COUNT

File Name : TH-280 AT Co Rd B 2007  
 Site Code : 00198741  
 Start Date : 6/5/2007  
 Page No : 4

Start Time	MN-280 Southbound					Co.Rd.B Westbound					MN-280 Northbound					City Street Eastbound					Int. Total
	Left	Thru	Right	Peds	App. Total	Left	Thru	Right	Peds	App. Total	Left	Thru	Right	Peds	App. Total	Left	Thru	Right	Peds	App. Total	

Peak Hour Analysis From 15:00 to 17:45 - Peak 1 of 1  
 Peak Hour for Entire Intersection Begins at 16:15

16:15	5	332	2	0	339	10	0	2	0	12	4	530	45	1	580	7	1	0	0	8	939
16:30	8	372	2	0	382	17	0	2	0	19	0	573	43	0	616	13	3	4	0	20	1037
16:45	2	370	3	0	375	15	0	2	0	17	4	539	67	0	610	4	1	1	0	6	1008
17:00	1	429	2	0	432	16	0	1	0	17	1	532	57	0	590	6	0	5	0	11	1050
Total Volume	16	1503	9	0	1528	58	0	7	0	65	9	2174	212	1	2396	30	5	10	0	45	4034
% App. Total	1	98.4	0.6	0		89.2	0	10.8	0		0.4	90.7	8.8	0		66.7	11.1	22.2	0		
PHF	.500	.876	.750	.000	.884	.853	.000	.875	.000	.855	.563	.949	.791	.250	.972	.577	.417	.500	.000	.563	.960

