

SEH CONSULTING
Traffic Data Collection
TURN MOVEMENT COUNT

TH-36 at Lake Elmo Ave N / CSAH-17
Ref.Pt.: 015.741
data by SEH
TURN MOVEMENT COUNT

File Name : TH-36 at Lake Elmo Ave N CSAH-17 2008
Site Code : 00000006
Start Date : 12/16/2008
Page No : 1

Groups Printed- Unshifted - Heavy Veh

Start Time	Lake Elmo Ave N / CSAH-17 Southbound				TH-36 Westbound				Lake Elmo Ave N / CSAH-17 Northbound				TH-36 Eastbound				Int. Total
	Left	Thru	Right	Peds	Left	Thru	Right	Peds	Left	Thru	Right	Peds	Left	Thru	Right	Peds	
06:00	2	7	40	0	3	291	1	0	5	3	4	0	1	85	1	0	443
06:15	0	6	38	0	5	317	2	0	12	3	0	0	4	86	2	0	475
06:30	0	16	60	0	5	340	9	0	8	4	0	0	6	140	4	0	592
06:45	10	22	59	0	5	354	6	0	9	9	1	0	5	171	6	0	657
Total	12	51	197	0	18	1302	18	0	34	19	5	0	16	482	13	0	2167
07:00	11	20	56	0	5	375	3	0	12	6	3	0	11	177	2	0	681
07:15	20	36	43	0	9	407	5	0	13	4	6	0	8	235	4	0	790
07:30	24	36	69	0	10	379	4	0	21	15	4	0	3	194	8	0	767
07:45	14	31	61	0	11	402	6	1	18	4	5	0	10	252	10	0	825
Total	69	123	229	0	35	1563	18	1	64	29	18	0	32	858	24	0	3063
08:00	14	36	41	0	8	366	4	0	13	6	2	0	11	215	8	0	724
08:15	9	22	43	0	9	339	4	0	13	8	4	0	12	213	5	0	681
08:30	9	13	42	0	9	325	4	0	9	5	13	0	12	202	4	0	647
08:45	7	15	37	0	6	241	4	0	23	8	12	0	5	265	10	0	633
Total	39	86	163	0	32	1271	16	0	58	27	31	0	40	895	27	0	2685
*** BREAK ***																	
11:00	8	7	11	0	3	251	3	0	8	5	2	0	5	192	7	0	502
11:15	8	4	12	0	7	239	4	0	7	3	3	0	9	202	9	0	507
11:30	7	7	12	0	3	255	5	0	8	7	1	0	5	181	9	0	500
11:45	10	2	13	0	5	233	4	0	6	3	7	0	11	223	4	0	521
Total	33	20	48	0	18	978	16	0	29	18	13	0	30	798	29	0	2030
12:00	15	8	12	0	8	244	5	0	11	7	6	0	7	198	8	0	529
12:15	14	5	8	0	5	240	6	0	10	5	8	0	12	225	4	0	542
12:30	10	3	8	0	8	225	9	0	8	6	3	0	13	207	4	0	504
12:45	8	6	9	0	8	209	3	0	9	5	3	0	14	253	6	0	533
Total	47	22	37	0	29	918	23	0	38	23	20	0	46	883	22	0	2108
*** BREAK ***																	
15:00	11	19	15	0	10	269	4	0	15	10	4	0	13	336	12	0	718
15:15	14	8	11	0	3	279	7	0	16	9	6	0	14	351	13	0	731
15:30	8	8	21	0	8	293	11	0	12	14	6	0	20	386	11	0	798
15:45	6	12	8	0	7	248	18	1	9	19	9	0	24	408	12	0	781
Total	39	47	55	0	28	1089	40	1	52	52	25	0	71	1481	48	0	3028
16:00	1	7	11	0	4	271	9	2	10	15	11	0	26	341	15	0	723
16:15	8	10	20	0	4	301	7	0	16	22	7	0	28	390	6	0	819
16:30	10	4	10	0	0	258	11	0	12	34	9	0	39	402	8	0	797
16:45	17	7	3	0	7	292	10	0	15	33	14	0	45	385	6	0	834
Total	36	28	44	0	15	1122	37	2	53	104	41	0	138	1518	35	0	3173
17:00	7	5	10	0	5	337	17	0	17	31	17	0	49	369	4	0	868
17:15	11	7	16	0	6	299	12	0	10	38	7	0	44	444	7	0	901
17:30	10	11	18	3	12	257	31	6	2	22	12	0	35	493	7	0	919
17:45	5	4	14	0	4	189	16	1	8	18	14	0	32	471	6	0	782
Total	33	27	58	3	27	1082	76	7	37	109	50	0	160	1777	24	0	3470
Grand Total	308	404	831	3	202	9325	244	11	365	381	203	0	533	8692	222	0	21724
Apprch %	19.9	26.1	53.8	0.2	2.1	95.3	2.5	0.1	38.5	40.1	21.4	0	5.6	92	2.3	0	
Total %	1.4	1.9	3.8	0	0.9	42.9	1.1	0.1	1.7	1.8	0.9	0	2.5	40	1	0	
Unshifted	306	400	827	3	201	9242	242	11	364	376	198	0	528	8581	220	0	21499
% Unshifted	99.4	99	99.5	100	99.5	99.1	99.2	100	99.7	98.7	97.5	0	99.1	98.7	99.1	0	99
Heavy Veh	2	4	4	0	1	83	2	0	1	5	5	0	5	111	2	0	225
% Heavy Veh	0.6	1	0.5	0	0.5	0.9	0.8	0	0.3	1.3	2.5	0	0.9	1.3	0.9	0	1

SEH CONSULTING
Traffic Data Collection
TURN MOVEMENT COUNT

TH-36 at Lake Elmo Ave N / CSAH-17
Ref.Pt.: 015.741
data by SEH
TURN MOVEMENT COUNT

File Name : TH-36 at Lake Elmo Ave N CSAH-17 2008
Site Code : 00000006
Start Date : 12/16/2008
Page No : 2

Start Time	Lake Elmo Ave N / CSAH-17 Southbound					TH-36 Westbound					Lake Elmo Ave N / CSAH-17 Northbound					TH-36 Eastbound					Int. Total
	Left	Thru	Right	Peds	App. Total	Left	Thru	Right	Peds	App. Total	Left	Thru	Right	Peds	App. Total	Left	Thru	Right	Peds	App. Total	
Peak Hour Analysis From 06:00 to 08:45 - Peak 1 of 1																					
Peak Hour for Entire Intersection Begins at 07:15																					
07:15	20	36	43	0	99	9	407	5	0	421	13	4	6	0	23	8	235	4	0	247	790
07:30	24	36	69	0	129	10	379	4	0	393	21	15	4	0	40	3	194	8	0	205	767
07:45	14	31	61	0	106	11	402	6	1	420	18	4	5	0	27	10	252	10	0	272	825
08:00	14	36	41	0	91	8	366	4	0	378	13	6	2	0	21	11	215	8	0	234	724
Total Volume	72	139	214	0	425	38	1554	19	1	1612	65	29	17	0	111	32	896	30	0	958	3106
% App. Total	16.9	32.7	50.4	0		2.4	96.4	1.2	0.1		58.6	26.1	15.3	0		3.3	93.5	3.1	0		
PHF	.750	.965	.775	.000	.824	.864	.955	.792	.250	.957	.774	.483	.708	.000	.694	.727	.889	.750	.000	.881	.941

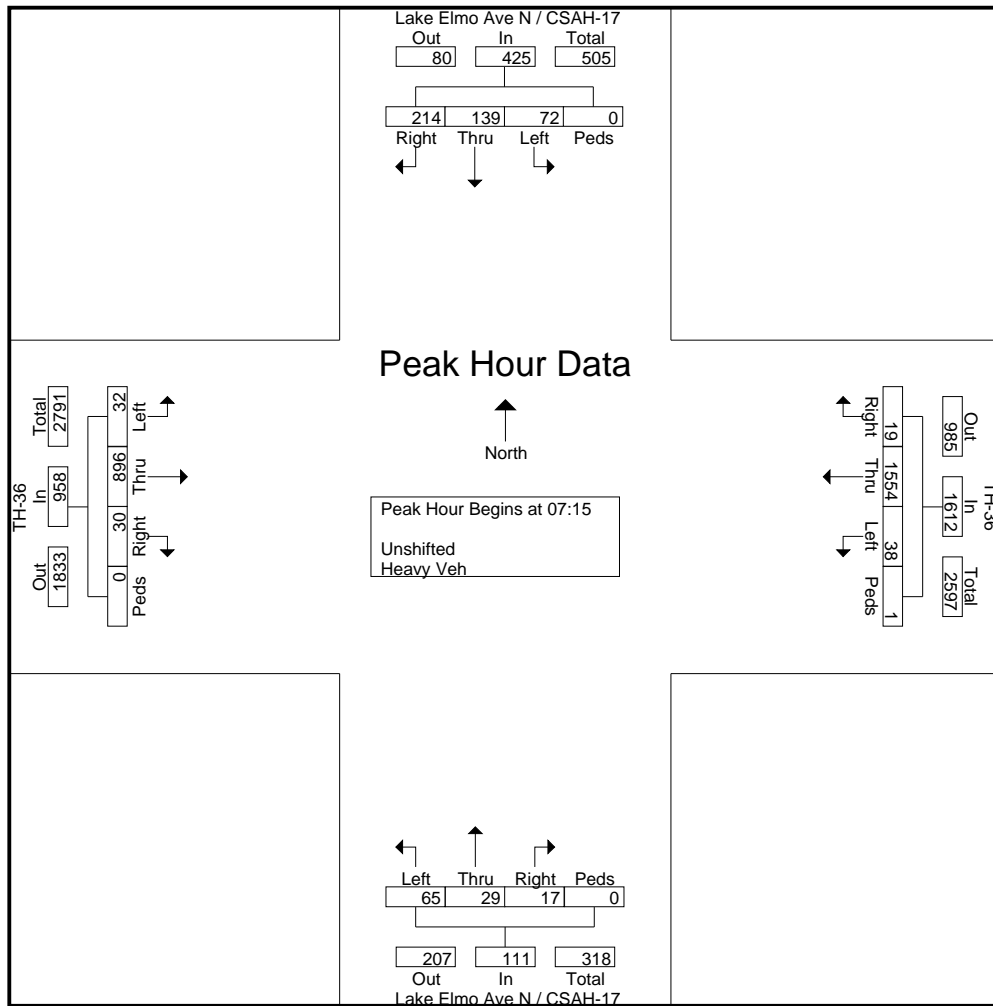

SEH CONSULTING
Traffic Data Collection
TURN MOVEMENT COUNT

TH-36 at Lake Elmo Ave N / CSAH-17
Ref.Pt.: 015.741
data by SEH
TURN MOVEMENT COUNT

File Name : TH-36 at Lake Elmo Ave N CSAH-17 2008
Site Code : 00000006
Start Date : 12/16/2008
Page No : 3

Start Time	Lake Elmo Ave N / CSAH-17 Southbound					TH-36 Westbound					Lake Elmo Ave N / CSAH-17 Northbound					TH-36 Eastbound					Int. Total
	Left	Thru	Right	Peds	App. Total	Left	Thru	Right	Peds	App. Total	Left	Thru	Right	Peds	App. Total	Left	Thru	Right	Peds	App. Total	
Peak Hour Analysis From 15:00 to 17:45 - Peak 1 of 1																					
Peak Hour for Entire Intersection Begins at 16:45																					
16:45	17	7	3	0	27	7	292	10	0	309	15	33	14	0	62	45	385	6	0	436	834
17:00	7	5	10	0	22	5	337	17	0	359	17	31	17	0	65	49	369	4	0	422	868
17:15	11	7	16	0	34	6	299	12	0	317	10	38	7	0	55	44	444	7	0	495	901
17:30	10	11	18	3	42	12	257	31	6	306	2	22	12	0	36	35	493	7	0	535	919
Total Volume	45	30	47	3	125	30	1185	70	6	1291	44	124	50	0	218	173	1691	24	0	1888	3522
% App. Total	36	24	37.6	2.4		2.3	91.8	5.4	0.5		20.2	56.9	22.9	0		9.2	89.6	1.3	0		
PHF	.662	.682	.653	.250	.744	.625	.879	.565	.250	.899	.647	.816	.735	.000	.838	.883	.858	.857	.000	.882	.958

