

SEH CONSULTING
Traffic Data Collection
TURN MOVEMENT COUNT

TH-36 at Manning Ave N / CSAH-15
Ref.Pt.: 016.721
data by SEH
TURN MOVEMENT COUNT

File Name : TH-36 at Manning Ave CSAH-15 2008
Site Code : 00000007
Start Date : 12/16/2008
Page No : 1

Groups Printed- Unshifted - Heavy Veh

Start Time	Manning Ave N / CSAH-15 Southbound				TH-36 Westbound				Manning Ave N Northbound				TH-36 Eastbound				Int. Total
	Left	Thru	Right	Peds	Left	Thru	Right	Peds	Left	Thru	Right	Peds	Left	Thru	Right	Peds	
06:00	18	3	70	0	0	220	5	0	1	1	1	1	5	71	0	0	396
06:15	23	0	90	0	0	253	7	0	0	0	1	0	7	97	0	0	478
06:30	41	0	100	0	1	268	10	0	0	0	0	0	9	122	2	0	553
06:45	41	0	85	0	0	298	10	0	0	1	0	0	6	172	1	0	614
Total	123	3	345	0	1	1039	32	0	1	2	2	1	27	462	3	0	2041
07:00	51	6	108	5	0	310	18	0	0	0	0	0	13	175	3	0	689
07:15	85	0	102	0	2	355	23	0	2	0	3	0	14	185	0	0	771
07:30	80	2	100	0	1	290	26	0	0	1	0	0	14	250	1	0	765
07:45	38	0	95	0	1	331	30	0	2	1	0	0	16	223	0	0	737
Total	254	8	405	5	4	1286	97	0	4	2	3	0	57	833	4	0	2962
08:00	46	1	66	0	2	317	30	0	1	1	0	0	17	248	1	0	730
08:15	56	0	78	0	2	222	32	0	1	0	2	0	30	184	0	0	607
08:30	49	0	71	0	2	260	23	0	2	0	0	0	14	195	1	0	617
08:45	58	0	55	0	1	192	19	0	2	0	1	0	23	268	2	0	621
Total	209	1	270	0	7	991	104	0	6	1	3	0	84	895	4	0	2575
*** BREAK ***																	
11:00	30	1	29	0	0	223	35	0	1	1	2	1	34	181	0	0	538
11:15	44	0	37	0	2	207	30	0	0	0	2	0	23	177	0	0	522
11:30	26	0	26	0	4	236	38	0	1	0	0	0	23	180	2	0	536
11:45	29	2	28	0	4	214	29	0	0	0	5	0	21	200	2	0	534
Total	129	3	120	0	10	880	132	0	2	1	9	1	101	738	4	0	2130
12:00	32	0	21	0	0	246	45	0	2	0	1	0	32	203	1	2	585
12:15	40	0	19	0	7	213	32	0	0	0	3	0	31	195	3	0	543
12:30	39	0	29	0	4	226	37	0	1	3	2	0	25	209	0	0	575
12:45	36	0	31	0	2	182	31	0	0	0	0	0	37	209	2	0	530
Total	147	0	100	0	13	867	145	0	3	3	6	0	125	816	6	2	2233
*** BREAK ***																	
15:00	49	0	42	0	3	280	60	0	2	0	1	0	52	264	0	0	753
15:15	40	0	33	0	2	323	90	0	0	0	3	0	59	301	2	0	853
15:30	51	1	33	0	1	314	126	7	0	0	0	0	44	140	0	0	717
15:45	43	0	40	0	1	265	81	0	0	0	0	0	29	150	0	0	609
Total	183	1	148	0	7	1182	357	7	2	0	4	0	184	855	2	0	2932
16:00	44	0	25	0	1	286	68	0	1	0	1	0	86	241	19	0	772
16:15	52	0	50	1	2	245	75	0	2	0	0	0	94	387	3	0	911
16:30	46	0	47	0	3	314	85	0	0	0	0	0	122	391	0	0	1008
16:45	64	0	37	0	4	257	80	0	0	0	2	0	100	372	2	0	918
Total	206	0	159	1	10	1102	308	0	3	0	3	0	402	1391	24	0	3609
17:00	54	0	27	0	2	317	106	0	0	0	2	0	115	350	2	0	975
17:15	56	0	44	0	0	318	115	0	1	0	1	0	81	201	0	0	817
17:30	53	0	45	0	2	240	73	0	0	0	1	0	129	372	1	0	916
17:45	68	0	30	0	1	216	87	0	1	0	0	0	115	372	1	0	891
Total	231	0	146	0	5	1091	381	0	2	0	4	0	440	1295	4	0	3599
Grand Total	1482	16	1693	6	57	8438	1556	7	23	9	34	2	1420	7285	51	2	22081
Apprch %	46.4	0.5	53	0.2	0.6	83.9	15.5	0.1	33.8	13.2	50	2.9	16.2	83.2	0.6	0	
Total %	6.7	0.1	7.7	0	0.3	38.2	7	0	0.1	0	0.2	0	6.4	33	0.2	0	
Unshifted	1466	15	1680	6	53	8310	1547	7	23	9	32	2	1412	7212	51	2	21827
% Unshifted	98.9	93.8	99.2	100	93	98.5	99.4	100	100	100	94.1	100	99.4	99	100	100	98.8
Heavy Veh	16	1	13	0	4	128	9	0	0	0	2	0	8	73	0	0	254
% Heavy Veh	1.1	6.2	0.8	0	7	1.5	0.6	0	0	0	5.9	0	0.6	1	0	0	1.2

SEH CONSULTING
Traffic Data Collection
TURN MOVEMENT COUNT

TH-36 at Manning Ave N / CSAH-15
Ref.Pt.: 016.721
data by SEH
TURN MOVEMENT COUNT

File Name : TH-36 at Manning Ave CSAH-15 2008
Site Code : 00000007
Start Date : 12/16/2008
Page No : 2

Start Time	Manning Ave N / CSAH-15 Southbound					TH-36 Westbound					Manning Ave N Northbound					TH-36 Eastbound					Int. Total
	Left	Thru	Right	Peds	App. Total	Left	Thru	Right	Peds	App. Total	Left	Thru	Right	Peds	App. Total	Left	Thru	Right	Peds	App. Total	
Peak Hour Analysis From 06:00 to 08:45 - Peak 1 of 1																					
Peak Hour for Entire Intersection Begins at 07:15																					
07:15	85	0	102	0	187	2	355	23	0	380	2	0	3	0	5	14	185	0	0	199	771
07:30	80	2	100	0	182	1	290	26	0	317	0	1	0	0	1	14	250	1	0	265	765
07:45	38	0	95	0	133	1	331	30	0	362	2	1	0	0	3	16	223	0	0	239	737
08:00	46	1	66	0	113	2	317	30	0	349	1	1	0	0	2	17	248	1	0	266	730
Total Volume	249	3	363	0	615	6	1293	109	0	1408	5	3	3	0	11	61	906	2	0	969	3003
% App. Total	40.5	0.5	59	0		0.4	91.8	7.7	0		45.5	27.3	27.3	0		6.3	93.5	0.2	0		
PHF	.732	.375	.890	.000	.822	.750	.911	.908	.000	.926	.625	.750	.250	.000	.550	.897	.906	.500	.000	.911	.974

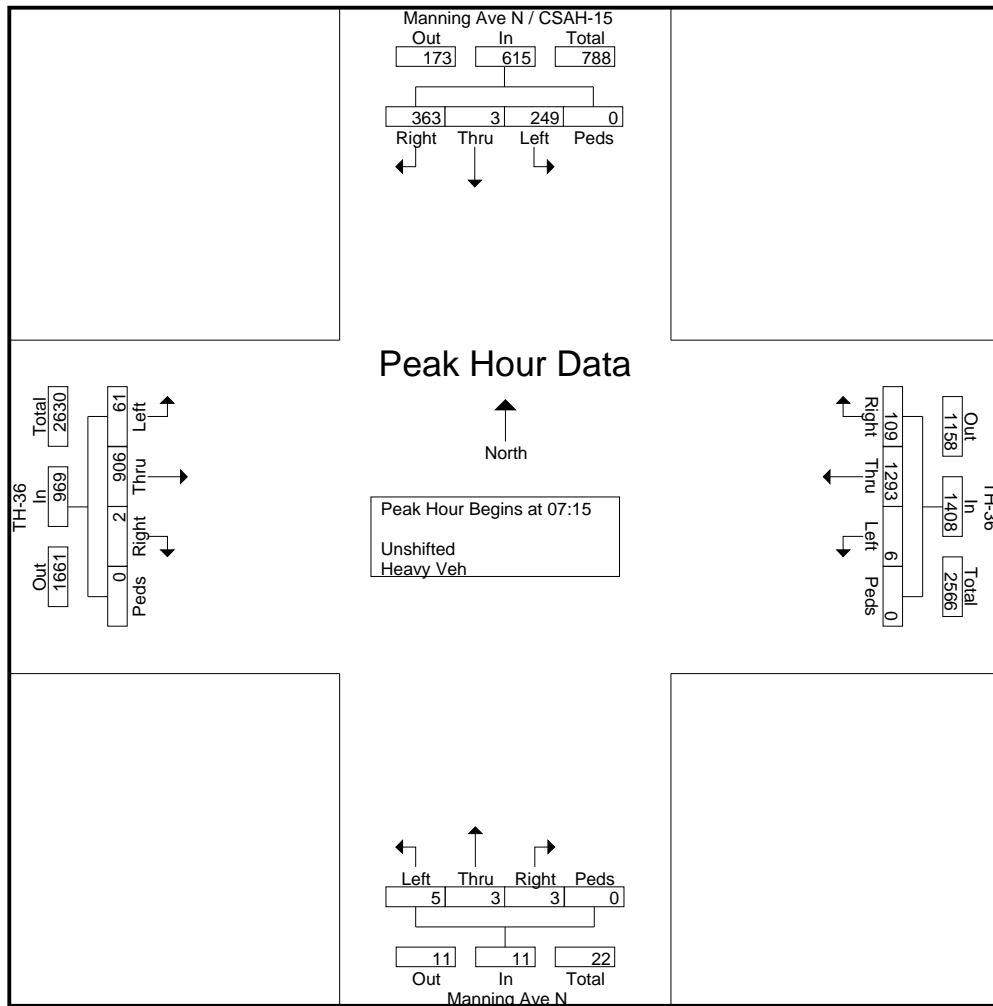

SEH CONSULTING
Traffic Data Collection
TURN MOVEMENT COUNT

TH-36 at Manning Ave N / CSAH-15
Ref.Pt.: 016.721
data by SEH
TURN MOVEMENT COUNT

File Name : TH-36 at Manning Ave CSAH-15 2008
Site Code : 00000007
Start Date : 12/16/2008
Page No : 3

Start Time	Manning Ave N / CSAH-15 Southbound					TH-36 Westbound					Manning Ave N Northbound					TH-36 Eastbound					Int. Total
	Left	Thru	Right	Peds	App. Total	Left	Thru	Right	Peds	App. Total	Left	Thru	Right	Peds	App. Total	Left	Thru	Right	Peds	App. Total	
Peak Hour Analysis From 15:00 to 17:45 - Peak 1 of 1																					
Peak Hour for Entire Intersection Begins at 16:15																					
16:15	52	0	50	1	103	2	245	75	0	322	2	0	0	0	2	94	387	3	0	484	911
16:30	46	0	47	0	93	3	314	85	0	402	0	0	0	0	0	122	391	0	0	513	1008
16:45	64	0	37	0	101	4	257	80	0	341	0	0	2	2	2	100	372	2	0	474	918
17:00	54	0	27	0	81	2	317	106	0	425	0	0	2	0	2	115	350	2	0	467	975
Total Volume	216	0	161	1	378	11	1133	346	0	1490	2	0	4	0	6	431	1500	7	0	1938	3812
% App. Total	57.1	0	42.6	0.3		0.7	76	23.2	0		33.3	0	66.7	0		22.2	77.4	0.4	0		
PHF	.844	.000	.805	.250	.917	.688	.894	.816	.000	.876	.250	.000	.500	.000	.750	.883	.959	.583	.000	.944	.945

