

SEH CONSULTING  
Traffic Data Collection  
TURN MOVEMENT COUNT

TH-95 / TH-36 at Nelson St E  
Ref.Pt.: 205.049 (TH-36)  
data by SEH  
TURN MOVEMENT COUNT

File Name : TH-95 at Nelson St 2008  
Site Code : 0000011  
Start Date : 12/10/2008  
Page No : 1

Groups Printed- Unshifted - Heavy Veh

Start Time	TH-95 / TH-36 Southbound				Nelson St. E Westbound				TH-95 / TH-36 Northbound				Nelson St. E Eastbound				Int. Total
	Left	Thru	Right	Peds	Left	Thru	Right	Peds	Left	Thru	Right	Peds	Left	Thru	Right	Peds	
06:00	0	246	0	0	0	0	0	0	1	23	0	0	0	0	0	0	270
06:15	0	253	0	1	1	0	0	0	1	41	1	0	0	0	0	1	299
06:30	1	260	0	0	5	0	1	0	0	46	1	0	0	0	3	2	319
06:45	1	251	0	1	1	1	1	0	0	68	1	0	0	0	2	3	330
Total	2	1010	0	2	7	1	2	0	2	178	3	0	0	0	5	6	1218
07:00	3	255	1	6	3	0	1	0	2	55	1	1	0	1	1	3	333
07:15	0	227	1	3	0	0	2	0	0	67	4	0	1	1	1	3	310
07:30	0	250	0	0	7	1	0	0	1	70	2	0	0	2	0	1	334
07:45	0	237	2	0	5	0	1	0	4	66	4	0	2	3	4	0	328
Total	3	969	4	9	15	1	4	0	7	258	11	1	3	7	6	7	1305
08:00	2	219	0	3	4	0	2	0	1	67	3	0	0	3	3	0	307
08:15	0	196	1	1	3	0	3	0	1	94	5	0	1	0	1	1	307
08:30	2	151	2	2	13	1	1	0	0	97	5	0	0	4	1	2	281
08:45	4	142	1	2	4	0	4	0	0	112	2	0	0	1	4	0	276
Total	8	708	4	8	24	1	10	0	2	370	15	0	1	8	9	3	1171
*** BREAK ***																	
11:00	3	94	0	1	5	0	4	1	1	82	5	4	0	1	3	6	210
11:15	3	101	2	9	16	1	4	5	3	101	9	5	1	1	2	7	270
11:30	7	116	0	2	8	0	4	1	0	109	8	3	3	1	2	7	271
11:45	6	109	3	10	2	2	5	3	0	105	7	3	0	2	0	9	266
Total	19	420	5	22	31	3	17	10	4	397	29	15	4	5	7	29	1017
12:00	3	104	1	7	7	0	1	1	2	97	10	4	1	4	0	6	248
12:15	5	104	1	6	1	0	5	1	1	98	6	3	1	2	1	6	241
12:30	3	122	2	14	5	2	4	7	2	116	2	2	2	3	3	5	294
12:45	3	122	3	5	11	0	2	9	0	98	2	3	4	2	2	4	270
Total	14	452	7	32	24	2	12	18	5	409	20	12	8	11	6	21	1053
*** BREAK ***																	
15:00	3	86	3	9	1	0	2	3	1	171	3	1	1	2	4	5	295
15:15	5	115	1	7	9	0	5	2	2	187	11	3	1	3	1	4	356
15:30	0	124	2	8	3	1	3	4	2	201	12	2	2	5	3	4	376
15:45	5	93	2	6	7	3	4	2	4	196	14	3	1	7	4	5	356
Total	13	418	8	30	20	4	14	11	9	755	40	9	5	17	12	18	1383
16:00	4	114	3	9	6	1	5	10	5	191	14	2	1	4	4	6	379
16:15	0	127	1	3	10	1	3	5	1	187	8	2	3	6	6	0	363
16:30	5	84	3	11	11	1	4	0	1	192	16	3	4	12	7	6	360
16:45	4	96	0	10	8	1	4	0	3	192	9	3	5	7	8	3	353
Total	13	421	7	33	35	4	16	15	10	762	47	10	13	29	25	15	1455
17:00	5	106	1	13	11	0	3	5	1	176	16	2	5	8	4	4	360
17:15	3	113	2	3	11	2	6	1	2	172	8	0	3	7	6	0	339
17:30	2	96	6	6	7	0	3	0	2	197	10	4	1	1	3	8	346
17:45	4	94	1	14	4	0	1	6	4	188	10	4	2	1	2	6	341
Total	14	409	10	36	33	2	13	12	9	733	44	10	11	17	15	18	1386
Grand Total	86	4807	45	172	189	18	88	66	48	3862	209	57	45	94	85	117	9988
Apprch %	1.7	94.1	0.9	3.4	52.4	5	24.4	18.3	1.1	92.5	5	1.4	13.2	27.6	24.9	34.3	
Total %	0.9	48.1	0.5	1.7	1.9	0.2	0.9	0.7	0.5	38.7	2.1	0.6	0.5	0.9	0.9	1.2	
Unshifted	86	4781	45	172	188	18	87	66	48	3835	209	57	45	93	85	117	9932
% Unshifted	100	99.5	100	100	99.5	100	98.9	100	100	99.3	100	100	100	98.9	100	100	99.4
Heavy Veh	0	26	0	0	1	0	1	0	0	27	0	0	0	1	0	0	56
% Heavy Veh	0	0.5	0	0	0.5	0	1.1	0	0	0.7	0	0	0	1.1	0	0	0.6

SEH CONSULTING  
Traffic Data Collection  
TURN MOVEMENT COUNT

TH-95 / TH-36 at Nelson St E  
Ref.Pt.: 205.049 (TH-36)  
data by SEH  
TURN MOVEMENT COUNT

File Name : TH-95 at Nelson St 2008  
Site Code : 0000011  
Start Date : 12/10/2008  
Page No : 2

Start Time	TH-95 / TH-36 Southbound					Nelson St. E Westbound					TH-95 / TH-36 Northbound					Nelson St. E Eastbound					Int. Total
	Left	Thru	Right	Peds	App. Total	Left	Thru	Right	Peds	App. Total	Left	Thru	Right	Peds	App. Total	Left	Thru	Right	Peds	App. Total	
Peak Hour Analysis From 06:00 to 08:45 - Peak 1 of 1																					
Peak Hour for Entire Intersection Begins at 06:45																					
06:45	1	251	0	1	253	1	1	1	0	3	0	68	1	0	69	0	0	2	3	5	330
07:00	3	255	1	6	265	3	0	1	0	4	2	55	1	1	59	0	1	1	3	5	333
07:15	0	227	1	3	231	0	0	2	0	2	0	67	4	0	71	1	1	1	3	6	310
07:30	0	250	0	0	250	7	1	0	0	8	1	70	2	0	73	0	2	0	1	3	334
Total Volume	4	983	2	10	999	11	2	4	0	17	3	260	8	1	272	1	4	4	10	19	1307
% App. Total	0.4	98.4	0.2	1		64.7	11.8	23.5	0		1.1	95.6	2.9	0.4		5.3	21.1	21.1	52.6		
PHF	.333	.964	.500	.417	.942	.393	.500	.500	.000	.531	.375	.929	.500	.250	.932	.250	.500	.500	.833	.792	.978

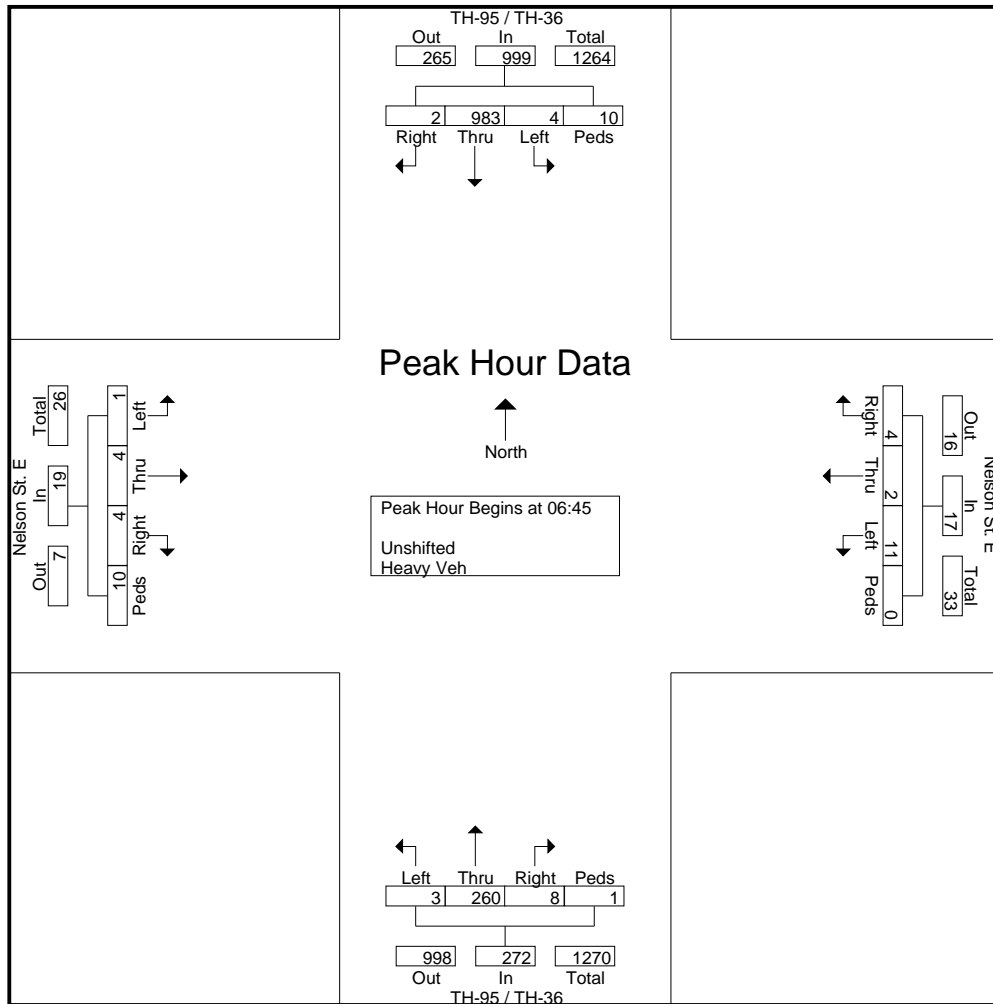

SEH CONSULTING  
Traffic Data Collection  
TURN MOVEMENT COUNT

TH-95 / TH-36 at Nelson St E  
Ref.Pt.: 205.049 (TH-36)  
data by SEH  
TURN MOVEMENT COUNT

File Name : TH-95 at Nelson St 2008  
Site Code : 0000011  
Start Date : 12/10/2008  
Page No : 3

Start Time	TH-95 / TH-36 Southbound					Nelson St. E Westbound					TH-95 / TH-36 Northbound					Nelson St. E Eastbound					Int. Total
	Left	Thru	Right	Peds	App. Total	Left	Thru	Right	Peds	App. Total	Left	Thru	Right	Peds	App. Total	Left	Thru	Right	Peds	App. Total	
Peak Hour Analysis From 15:00 to 17:45 - Peak 1 of 1																					
Peak Hour for Entire Intersection Begins at 15:30																					
15:30	0	124	2	8	134	3	1	3	4	11	2	201	12	2	217	2	5	3	4	14	376
15:45	5	93	2	6	106	7	3	4	2	16	4	196	14	3	217	1	7	4	5	17	356
16:00	4	114	3	9	130	6	1	5	10	22	5	191	14	2	212	1	4	4	6	15	379
16:15	0	127	1	3	131	10	1	3	5	19	1	187	8	2	198	3	6	6	0	15	363
Total Volume	9	458	8	26	501	26	6	15	21	68	12	775	48	9	844	7	22	17	15	61	1474
% App. Total	1.8	91.4	1.6	5.2		38.2	8.8	22.1	30.9		1.4	91.8	5.7	1.1		11.5	36.1	27.9	24.6		
PHF	.450	.902	.667	.722	.935	.650	.500	.750	.525	.773	.600	.964	.857	.750	.972	.583	.786	.708	.625	.897	.972

