

MN Dept of Transportation

TRAFFIC DATA COLLECTION - Metro

TH-41 at Lyman Blvd / CSAH-18 CHASKA

Ref.Pt.: 006.230

video RE

TURN MOVEMENT COUNT

File Name : TH-47 at Lyman Blvd 2014

Site Code :

Start Date : 12/11/2014

Page No : 1

Groups Printed- Cars +

Start Time	TH-41 Southbound				Lyman Blvd / CSAH-18 Westbound				TH-41 Northbound				Lyman Blvd Eastbound				Int. Total
	Left	Thru	Right	Peds	Left	Thru	Right	Peds	Left	Thru	Right	Peds	Left	Thru	Right	Peds	
06:00	12	22	2	0	2	4	6	0	7	39	21	0	1	0	1	0	117
06:15	12	29	5	0	9	1	9	0	4	52	28	0	0	0	0	0	149
06:30	18	40	6	0	3	5	5	0	9	86	49	0	1	0	0	0	222
06:45	24	53	12	0	12	7	4	0	11	86	51	0	1	0	0	0	261
Total	66	144	25	0	26	17	24	0	31	263	149	0	3	0	1	0	749
07:00	28	63	6	0	26	9	7	0	10	68	50	0	1	1	1	0	270
07:15	42	70	11	0	16	2	17	0	9	111	62	0	0	0	0	0	340
07:30	41	71	10	0	19	3	8	0	9	104	56	0	0	0	0	0	321
07:45	80	79	12	0	23	4	5	0	11	119	80	0	0	0	0	0	413
Total	191	283	39	0	84	18	37	0	39	402	248	0	1	1	1	0	1344
08:00	62	75	16	0	27	2	13	0	21	137	85	0	1	1	1	0	441
08:15	23	70	13	0	16	2	9	0	9	119	48	0	2	0	0	0	311
08:30	23	71	5	0	27	3	12	0	9	105	36	0	0	3	0	0	294
08:45	11	85	5	0	19	9	7	0	4	95	37	0	1	0	1	0	274
Total	119	301	39	0	89	16	41	0	43	456	206	0	4	4	2	0	1320
*****BREAK*****																	
15:00	10	103	2	0	80	2	44	0	0	122	33	0	10	1	6	0	413
15:15	7	128	3	0	57	2	39	0	0	104	34	0	5	4	4	0	387
15:30	5	143	0	0	45	2	31	0	0	115	16	0	14	6	9	0	386
15:45	10	134	1	0	20	2	22	0	0	103	22	0	9	4	5	0	332
Total	32	508	6	0	202	8	136	0	0	444	105	0	38	15	24	0	1518
16:00	7	118	0	0	62	0	41	0	0	121	37	0	11	6	8	0	411
16:15	3	116	0	0	53	0	28	0	3	120	18	0	10	7	5	0	363
16:30	8	128	2	0	48	0	35	0	2	138	27	0	19	5	17	0	429
16:45	7	137	2	0	47	2	35	0	0	120	20	0	15	5	16	0	406
Total	25	499	4	0	210	2	139	0	5	499	102	0	55	23	46	0	1609
17:00	6	131	0	0	75	0	34	0	0	109	15	0	21	4	15	0	410
17:15	2	142	2	0	54	2	31	0	0	136	17	0	8	4	9	0	407
17:30	3	142	1	0	38	1	17	0	2	114	16	0	10	1	9	0	354
17:45	6	140	0	0	30	0	17	0	0	99	19	0	4	2	5	0	322
Total	17	555	3	0	197	3	99	0	2	458	67	0	43	11	38	0	1493
Grand Total	450	2290	116	0	808	64	476	0	120	2522	877	0	144	54	112	0	8033
Apprch %	15.8	80.2	4.1	0	59.9	4.7	35.3	0	3.4	71.7	24.9	0	46.5	17.4	36.1	0	
Total %	5.6	28.5	1.4	0	10.1	0.8	5.9	0	1.5	31.4	10.9	0	1.8	0.7	1.4	0	

MN Dept of Transportation

TRAFFIC DATA COLLECTION - Metro

TH-41 at Lyman Blvd / CSAH-18 CHASKA
 Ref.Pt.: 006.230
 video RE
 TURN MOVEMENT COUNT

File Name : TH-47 at Lyman Blvd 2014
 Site Code :
 Start Date : 12/11/2014
 Page No : 2

Start Time	TH-41 Southbound					Lyman Blvd / CSAH-18 Westbound					TH-41 Northbound					Lyman Blvd Eastbound					Int. Total
	Left	Thru	Right	Peds	App. Total	Left	Thru	Right	Peds	App. Total	Left	Thru	Right	Peds	App. Total	Left	Thru	Right	Peds	App. Total	
Peak Hour Analysis From 06:00 to 08:45 - Peak 1 of 1																					
Peak Hour for Entire Intersection Begins at 07:15																					
07:15	42	70	11	0	123	16	2	17	0	35	9	111	62	0	182	0	0	0	0	0	340
07:30	41	71	10	0	122	19	3	8	0	30	9	104	56	0	169	0	0	0	0	0	321
07:45	80	79	12	0	171	23	4	5	0	32	11	119	80	0	210	0	0	0	0	0	413
08:00	62	75	16	0	153	27	2	13	0	42	21	137	85	0	243	1	1	1	0	3	441
Total Volume	225	295	49	0	569	85	11	43	0	139	50	471	283	0	804	1	1	1	0	3	1515
% App. Total	39.5	51.8	8.6	0		61.2	7.9	30.9	0		6.2	58.6	35.2	0		33.3	33.3	33.3	0		
PHF	.703	.934	.766	.000	.832	.787	.688	.632	.000	.827	.595	.859	.832	.000	.827	.250	.250	.250	.000	.250	.859

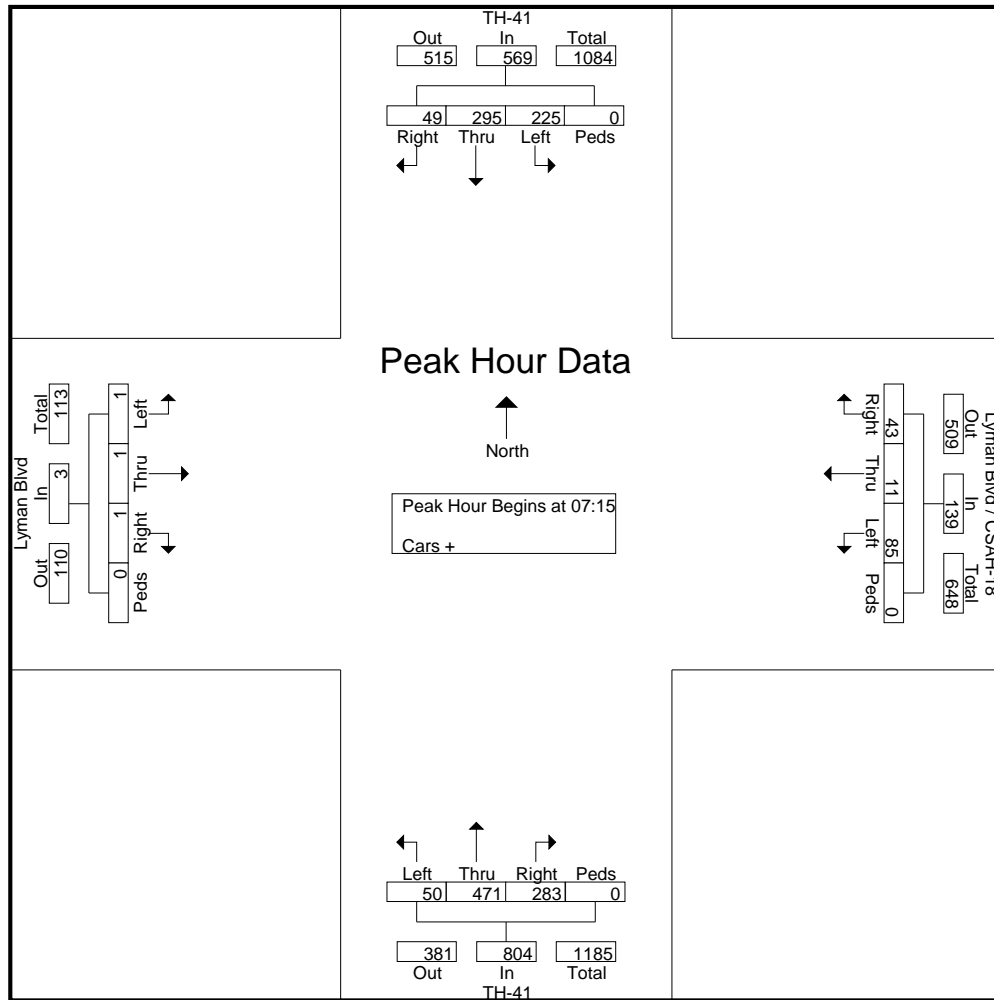

MN Dept of Transportation

TRAFFIC DATA COLLECTION - Metro

TH-41 at Lyman Blvd / CSAH-18 CHASKA
 Ref.Pt.: 006.230
 video RE
 TURN MOVEMENT COUNT

File Name : TH-47 at Lyman Blvd 2014
 Site Code :
 Start Date : 12/11/2014
 Page No : 3

Start Time	TH-41 Southbound					Lyman Blvd / CSAH-18 Westbound					TH-41 Northbound					Lyman Blvd Eastbound					Int. Total
	Left	Thru	Right	Peds	App. Total	Left	Thru	Right	Peds	App. Total	Left	Thru	Right	Peds	App. Total	Left	Thru	Right	Peds	App. Total	
Peak Hour Analysis From 15:00 to 17:45 - Peak 1 of 1																					
Peak Hour for Entire Intersection Begins at 16:30																					
16:30	8	128	2	0	138	48	0	35	0	83	2	138	27	0	167	19	5	17	0	41	429
16:45	7	137	2	0	146	47	2	35	0	84	0	120	20	0	140	15	5	16	0	36	406
17:00	6	131	0	0	137	75	0	34	0	109	0	109	15	0	124	21	4	15	0	40	410
17:15	2	142	2	0	146	54	2	31	0	87	0	136	17	0	153	8	4	9	0	21	407
Total Volume	23	538	6	0	567	224	4	135	0	363	2	503	79	0	584	63	18	57	0	138	1652
% App. Total	4.1	94.9	1.1	0		61.7	1.1	37.2	0		0.3	86.1	13.5	0		45.7	13	41.3	0		
PHF	.719	.947	.750	.000	.971	.747	.500	.964	.000	.833	.250	.911	.731	.000	.874	.750	.900	.838	.000	.841	.963

