

# ALLIANT ENGINEERING, INC.

733 S Marquette Ave #700, Minneapolis, MN 55402

Intersection: TH 47 & 85th Avenue  
 Date: 3/21/2024  
 Duration: 0600-1800

Site Code: 615  
 Ref Pt: N/A  
 Page No: 1 of 4

All Vehicles (Cars & Trucks) Printed

Start Time	TH 47 Southbound						85th Avenue Westbound						TH 47 Northbound						85th Avenue Eastbound						Int. Veh. Total	Int. Ped/Bike Total	
	U-Turn	Left	Thru	Right	App. Total	Peds/Bikes	U-Turn	Left	Thru	Right	App. Total	Peds/Bikes	U-Turn	Left	Thru	Right	App. Total	Peds/Bikes	U-Turn	Left	Thru	Right	App. Total	Peds/Bikes			
6:00	1	3	99	22	125	--	--	4	4	2	10	1	--	19	46	3	68	1	--	9	3	4	16	--	219	2	
6:15	--	2	154	25	181	--	--	3	2	2	7	--	--	9	59	4	72	--	--	12	1	10	23	--	283	--	
6:30	--	2	181	28	211	--	--	6	4	2	12	--	--	20	70	1	91	--	--	20	5	6	31	--	345	--	
6:45	1	6	224	39	270	--	--	5	11	3	19	--	--	24	81	2	107	--	--	23	8	11	42	--	438	--	
Hour Total	2	13	658	114	787	--	--	18	21	9	48	1	--	72	256	10	338	1	--	64	17	31	112	--	1285	2	
7:00	--	--	163	28	191	--	--	6	5	2	13	3	--	18	92	7	117	3	--	16	8	18	42	--	363	6	
7:15	--	4	209	34	247	--	--	6	7	4	17	--	--	20	99	8	127	--	--	25	11	17	53	--	444	--	
7:30	--	1	300	30	331	--	--	5	8	4	17	--	--	34	145	6	185	--	--	29	10	15	54	--	587	--	
7:45	--	5	278	34	317	--	--	6	8	5	19	1	--	38	102	9	149	1	--	31	11	22	64	--	549	2	
Hour Total	--	10	950	126	1086	--	--	23	28	15	66	4	--	110	438	30	578	4	--	101	40	72	213	--	1943	8	
8:00	--	3	221	39	263	1	--	11	5	4	20	--	--	35	103	8	146	--	--	25	7	19	51	1	480	2	
8:15	--	1	156	43	200	--	--	8	8	2	18	--	8	43	116	5	172	--	--	35	3	17	55	--	445	--	
8:30	--	--	129	18	147	--	--	6	8	3	17	--	1	34	87	10	132	--	--	22	12	29	63	--	359	--	
8:45	--	7	153	34	194	1	--	11	11	4	26	--	2	41	104	12	159	1	--	20	17	28	65	1	444	3	
Hour Total	--	11	659	134	804	2	--	36	32	13	81	--	11	153	410	35	609	1	--	102	39	93	234	2	1728	5	
9:00	1	5	135	21	162	1	--	8	16	7	31	--	3	51	135	16	205	--	--	30	16	25	71	1	469	2	
9:15	--	6	138	29	173	--	--	8	13	9	30	--	--	38	93	22	153	--	--	29	16	25	70	--	426	--	
9:30	1	6	109	29	145	--	--	11	16	5	32	1	1	27	88	16	132	1	--	34	25	28	87	--	396	2	
9:45	1	7	132	29	169	1	--	13	23	9	45	1	1	37	110	17	165	1	--	28	15	25	68	--	447	3	
Hour Total	3	24	514	108	649	2	--	40	68	30	138	2	5	153	426	71	655	2	--	121	72	103	296	1	1738	7	
10:00	--	9	109	28	146	2	--	18	26	5	49	1	--	19	81	10	110	2	--	42	19	22	83	--	388	5	
10:15	2	3	118	31	154	2	--	16	19	5	40	--	--	42	125	17	184	--	--	34	20	51	105	1	483	3	
10:30	1	8	132	30	171	3	--	5	15	2	22	--	--	37	123	15	175	1	--	38	30	40	108	--	476	4	
10:45	1	9	140	34	184	2	--	14	18	5	37	--	1	49	134	27	211	2	--	44	29	38	111	--	543	4	
Hour Total	4	29	499	123	655	9	--	53	78	17	148	1	1	147	463	69	680	5	--	158	98	151	407	1	1890	16	
11:00	--	11	107	34	152	2	--	13	27	10	50	--	1	42	134	34	211	--	--	37	22	48	107	--	520	2	
11:15	1	8	129	35	173	--	--	19	28	9	56	--	2	42	131	26	201	1	--	50	24	35	109	--	539	1	
11:30	2	9	134	40	185	1	--	26	19	7	52	--	--	39	126	35	200	1	--	52	40	51	143	--	580	2	
11:45	1	7	113	46	167	--	--	22	37	13	72	2	1	46	122	35	204	3	--	51	34	47	132	--	575	5	
Hour Total	4	35	483	155	677	3	--	80	111	39	230	2	4	169	513	130	816	5	--	190	120	181	491	--	2214	10	
12:00	--	11	124	48	183	--	--	20	36	10	66	--	--	46	168	31	245	1	--	52	43	51	146	--	640	1	
12:15	--	4	124	50	178	1	--	25	36	14	75	--	1	48	123	30	202	1	--	63	36	34	133	--	588	2	
12:30	2	6	107	55	170	1	--	26	31	6	63	--	3	43	135	22	203	3	--	55	35	42	132	1	568	5	
12:45	1	14	139	39	193	--	--	28	34	12	74	--	--	51	155	28	234	1	--	69	38	45	152	--	653	1	
Hour Total	3	35	494	192	724	2	--	99	137	42	278	--	4	188	581	111	884	6	--	239	152	172	563	1	2449	9	
13:00	1	4	129	27	161	--	--	22	25	8	55	1	1	48	138	27	214	1	--	45	25	40	110	--	540	2	
13:15	1	9	111	44	165	--	--	27	26	12	65	--	1	36	159	29	225	--	--	54	21	36	111	--	566	--	
13:30	2	3	133	46	184	1	--	18	38	10	66	1	1	44	186	23	254	--	--	60	26	55	141	--	645	2	
13:45	--	9	130	32	171	--	--	26	19	9	54	--	2	56	142	26	226	2	--	40	27	31	98	--	549	2	
Hour Total	4	25	503	149	681	1	--	93	108	39	240	2	5	184	625	105	919	3	--	199	99	162	460	--	2300	6	
14:00	1	10	140	47	198	2	--	22	32	17	71	--	2	33	176	24	235	1	--	62	26	34	122	--	626	3	
14:15	--	9	145	47	201	--	--	25	39	9	73	--	--	50	197	28	275	1	--	50	35	46	131	--	680	1	
14:30	2	9	145	51	207	1	--	25	27	6	58	--	2	43	244	35	324	--	--	77	40	41	158	1	747	2	
14:45	2	9	174	64	249	2	--	10	28	13	51	--	1	46	243	34	324	--	--	69	24	55	148	--	772	2	
Hour Total	5	37	604	209	855	5	--	82	126	45	253	--	5	172	860	121	1158	2	--	258	125	176	559	1	2825	8	
15:00	--	17	138	54	209	2	--	25	39	12	76	1	1	65	294	31	391	1	--	104	38	42	184	--	860	4	
15:15	3	7	167	83	260	--	--	31	33	12	76	--	1	56	255	32	344	--	--	1	72	31	54	158	--	838	--
15:30	1	14	164	60	239	--	--	19	29	16	64	2	5	42	332	21	400	2	--	97	35	55	187	--	890	4	
15:45	--	7	154	50	211	1	--	15	35	9	59	--	2	44	285	23	354	--	--	77	52	49	178	1	802	2	
Hour Total	4	45	623	247	919	3	--	90	136	49	275	3	9	207	1166	107	1489	3	1	350	156	200	707	1	3390	10	
16:00	1	10	125	60	196	1	--	26	32	18	76	--	2	53	334	32	421	1	1	89	43	65	198	--	891	2	
16:15	--	14	168	64	246	--	--	21	30	13	64	1	--	63	316	28	407	1	1	79	35	47	162	--	879	2	
16:30	1	10	167	71	249	--	--	28	25	16	69	1	--	45	306	30	381	1	1	99	40	59	199	--	898	2	
16:45	1	13	162	63	239	--	1	27	33	16	77	--	--	63	260	30	353	--	--	81	42	54	177	--	846	--	
Hour Total	3	47	622	258	930	1	1	102	120	63	286	2	2	224	1216	120	1562	3	3	348	160	225	736	--	3514	6	
17:00	--	11	135	50	196	2	--	22	35	8	65	2	2	46	253	34	335	2	--	90	33	47	170	--	766	6	
17:15	--	11	174	45	230	--	--	17	27	11	55	--	1	56	256	39	352	--	--	70	29	36	135	--	772	--	
17:30	--	10	155	43	208	--	--	32	42	15	89	--	--	50	226	23	299	--	--	80	42	46	168	--	764	--	
17:45	2	17	118	35	172	1	--	28	36	19	83	--	1	40	178	29	248	--	--	65	32	49	146	--	649	1	
Hour Total	2	49	582	173	806	3	--	99	140	53	292	2	4	192	913	125	1234	2	--	305	136	178	619	--	2951	7	
Grand Total	34	360	7191	1988	9573	31	1	815	1105	414	2335	19	50	1971	7867	1034	10922	37	4	2435	1214	1744	5397	7	28227	94	
% of App.	0.4%	3.8%	75.1%	20.8%			0.0%	34.9%	47																		

# ALLIANT ENGINEERING, INC.

733 S Marquette Ave #700, Minneapolis, MN 55402

Intersection: TH 47 & 85th Avenue  
 Date: 3/21/2024  
 Duration: 0600-1800

Site Code: 615  
 Ref Pt: N/A  
 Page No: 2 of 4

All Vehicles (Cars & Trucks) Printed

Start Time	TH 47 Southbound						85th Avenue Westbound						TH 47 Northbound						85th Avenue Eastbound						Int. Veh. Total	Int. Ped/Bike Total
	U-Turn	Left	Thru	Right	App. Total	Peds/Bikes	U-Turn	Left	Thru	Right	App. Total	Peds/Bikes	U-Turn	Left	Thru	Right	App. Total	Peds/Bikes	U-Turn	Left	Thru	Right	App. Total	Peds/Bikes		
7:30	--	1	300	30	<b>331</b>	--	--	5	8	4	<b>17</b>	--	--	34	145	6	<b>185</b>	--	--	29	10	15	<b>54</b>	--	587	--
7:45	--	5	278	34	<b>317</b>	--	--	6	8	5	<b>19</b>	1	--	38	102	9	<b>149</b>	1	--	31	11	22	<b>64</b>	--	549	2
8:00	--	3	221	39	<b>263</b>	1	--	11	5	4	<b>20</b>	--	--	35	103	8	<b>146</b>	--	--	25	7	19	<b>51</b>	1	480	2
8:15	--	1	156	43	<b>200</b>	--	--	8	8	2	<b>18</b>	--	8	43	116	5	<b>172</b>	--	--	35	3	17	<b>55</b>	--	445	--
Hour Total	--	10	955	146	<b>1111</b>	1	--	30	29	15	<b>74</b>	1	8	150	466	28	<b>652</b>	1	--	120	31	73	<b>224</b>	1	2061	4
% of App.	0.0%	0.9%	86.0%	13.1%			0.0%	40.5%	39.2%	20.3%			1.2%	23.0%	71.5%	4.3%			0.0%	53.6%	13.8%	32.6%				
% of Total	0.0%	0.5%	46.3%	7.1%	53.9%	25.0%	0.0%	1.5%	1.4%	0.7%	3.6%	25.0%	0.4%	7.3%	22.6%	1.4%	31.6%	25.0%	0.0%	5.8%	1.5%	3.5%	10.9%	25.0%		
Cars Total	--	8	931	141	<b>1080</b>	1	--	23	26	11	<b>60</b>	1	8	147	445	21	<b>621</b>	1	--	115	28	68	<b>211</b>	1	1972	4
Cars % of Movement	0.0%	80.0%	97.5%	96.6%	97.2%	25.0%	0.0%	76.7%	89.7%	73.3%	81.1%	25.0%	100%	98.0%	95.5%	75.0%	95.2%	25.0%	0.0%	95.8%	90.3%	93.2%	94.2%	25.0%	95.7%	
Trucks Total	--	2	24	5	<b>31</b>	--	--	7	3	4	<b>14</b>	--	--	3	21	7	<b>31</b>	--	--	5	3	5	<b>13</b>	--	89	--
Trucks % of Movement	0.0%	20.0%	2.5%	3.4%	2.8%	--	0.0%	23.3%	10.3%	26.7%	18.9%	--	0.0%	2.0%	4.5%	25.0%	4.8%	--	0.0%	4.2%	9.7%	6.8%	5.8%	--	4.3%	

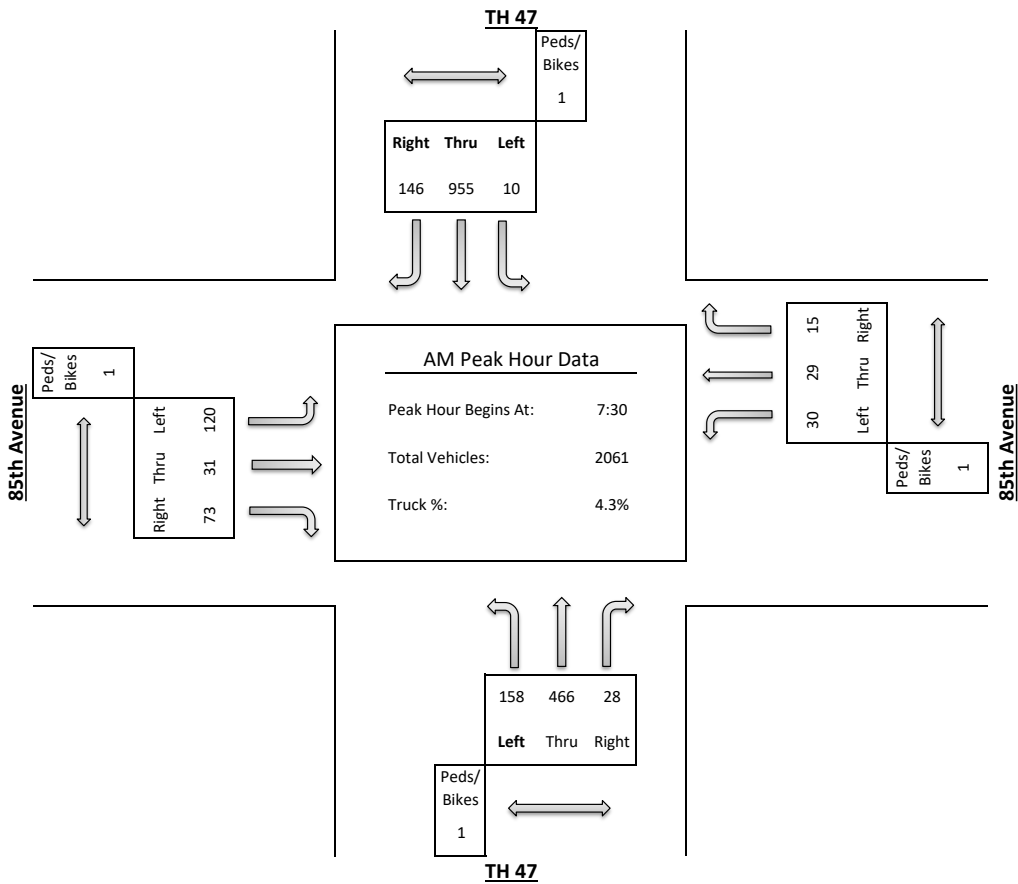

# ALLIANT ENGINEERING, INC.

733 S Marquette Ave #700, Minneapolis, MN 55402

Intersection: TH 47 & 85th Avenue  
 Date: 3/21/2024  
 Duration: 0600-1800

Site Code: 615  
 Ref Pt: N/A  
 Page No: 3 of 4

All Vehicles (Cars & Trucks) Printed

Start Time	TH 47 Southbound						85th Avenue Westbound						TH 47 Northbound						85th Avenue Eastbound						Int. Veh. Total	Int. Ped/Bike Total
	U-Turn	Left	Thru	Right	App. Total	Peds/Bikes	U-Turn	Left	Thru	Right	App. Total	Peds/Bikes	U-Turn	Left	Thru	Right	App. Total	Peds/Bikes	U-Turn	Left	Thru	Right	App. Total	Peds/Bikes		
12:00	--	11	124	48	183	--	--	20	36	10	66	--	--	46	168	31	245	1	--	52	43	51	146	--	640	1
12:15	--	4	124	50	178	1	--	25	36	14	75	--	1	48	123	30	202	1	--	63	36	34	133	--	588	2
12:30	2	6	107	55	170	1	--	26	31	6	63	--	3	43	135	22	203	3	--	55	35	42	132	1	568	5
12:45	1	14	139	39	193	--	--	28	34	12	74	--	--	51	155	28	234	1	--	69	38	45	152	--	653	1
<b>Hour Total</b>	<b>3</b>	<b>35</b>	<b>494</b>	<b>192</b>	<b>724</b>	<b>2</b>	<b>--</b>	<b>99</b>	<b>137</b>	<b>42</b>	<b>278</b>	<b>--</b>	<b>4</b>	<b>188</b>	<b>581</b>	<b>111</b>	<b>884</b>	<b>6</b>	<b>--</b>	<b>239</b>	<b>152</b>	<b>172</b>	<b>563</b>	<b>1</b>	<b>2449</b>	<b>9</b>
% of App.	0.4%	4.8%	68.2%	26.5%			0.0%	35.6%	49.3%	15.1%			0.5%	21.3%	65.7%	12.6%			0.0%	42.5%	27.0%	30.6%				
% of Total	0.1%	1.4%	20.2%	7.8%	29.6%	22.2%	0.0%	4.0%	5.6%	1.7%	11.4%	0.0%	0.2%	7.7%	23.7%	4.5%	36.1%	66.7%	0.0%	9.8%	6.2%	7.0%	23.0%	11.1%		
Cars Total	3	31	477	189	700	2	--	91	134	39	264	--	4	182	564	105	855	4	--	235	148	164	547	1	2366	7
Cars % of Movement	100%	88.6%	96.6%	98.4%	96.7%	28.6%	0.0%	91.9%	97.8%	92.9%	95.0%	0.0%	100%	96.8%	97.1%	94.6%	96.7%	57.1%	0.0%	98.3%	97.4%	95.3%	97.2%	14.3%	96.6%	
Trucks Total	--	4	17	3	24	--	--	8	3	3	14	--	--	6	17	6	29	2	--	4	4	8	16	--	83	2
Trucks % of Movement	0.0%	11.4%	3.4%	1.6%	3.3%	0.0%	0.0%	8.1%	2.2%	7.1%	5.0%	0.0%	0.0%	3.2%	2.9%	5.4%	3.3%	#####	0.0%	1.7%	2.6%	4.7%	2.8%	0.0%	3.4%	

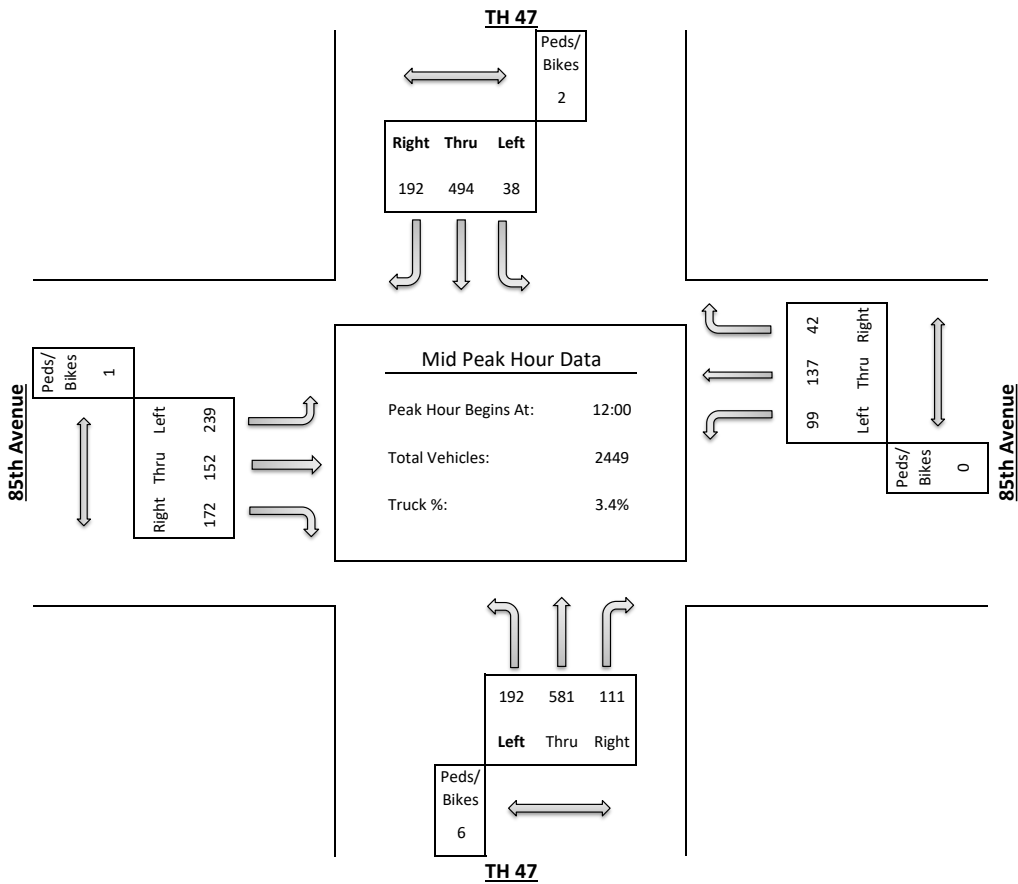

# ALLIANT ENGINEERING, INC.

733 S Marquette Ave #700, Minneapolis, MN 55402

Intersection: TH 47 & 85th Avenue  
 Date: 3/21/2024  
 Duration: 0600-1800

Site Code: 615  
 Ref Pt: N/A  
 Page No: 4 of 4

All Vehicles (Cars & Trucks) Printed

Start Time	TH 47 Southbound						85th Avenue Westbound						TH 47 Northbound						85th Avenue Eastbound						Int. Veh. Total	Int. Ped/Bike Total
	U-Turn	Left	Thru	Right	App. Total	Peds/Bikes	U-Turn	Left	Thru	Right	App. Total	Peds/Bikes	U-Turn	Left	Thru	Right	App. Total	Peds/Bikes	U-Turn	Left	Thru	Right	App. Total	Peds/Bikes		
16:00	1	10	125	60	196	1	--	26	32	18	76	--	2	53	334	32	421	1	1	89	43	65	198	--	891	2
16:15	--	14	168	64	246	--	--	21	30	13	64	1	--	63	316	28	407	1	1	79	35	47	162	--	879	2
16:30	1	10	167	71	249	--	--	28	25	16	69	1	--	45	306	30	381	1	1	99	40	59	199	--	898	2
16:45	1	13	162	63	239	--	1	27	33	16	77	--	--	63	260	30	353	--	--	81	42	54	177	--	846	--
<b>Hour Total</b>	<b>3</b>	<b>47</b>	<b>622</b>	<b>258</b>	<b>930</b>	<b>1</b>	<b>1</b>	<b>102</b>	<b>120</b>	<b>63</b>	<b>286</b>	<b>2</b>	<b>2</b>	<b>224</b>	<b>1216</b>	<b>120</b>	<b>1562</b>	<b>3</b>	<b>3</b>	<b>348</b>	<b>160</b>	<b>225</b>	<b>736</b>	<b>--</b>	<b>3514</b>	<b>6</b>
% of App.	0.3%	5.1%	66.9%	27.7%	0.3% 35.7% 42.0% 22.0%						0.1% 14.3% 77.8% 7.7%						0.4% 47.3% 21.7% 30.6%									
% of Total	0.1%	1.3%	17.7%	7.3%	26.5%	16.7%	0.0% 2.9% 3.4% 1.8% 8.1% 33.3%						0.1% 6.4% 34.6% 3.4% 44.5% 50.0%						0.1% 9.9% 4.6% 6.4% 20.9% 0.0%							
Cars Total	3	45	608	254	910	1	1	95	119	61	276	2	2	220	1209	116	1547	3	3	346	160	223	732	--	3465	6
Cars % of Movement	100%	95.7%	97.7%	98.4%	97.8%	16.7%	100%	93.1%	99.2%	96.8%	96.5%	33.3%	100%	98.2%	99.4%	96.7%	99.0%	50.0%	100%	99.4%	100%	99.1%	99.5%	0.0%	98.6%	
Trucks Total	--	2	14	4	20	--	--	7	1	2	10	--	--	4	7	4	15	--	--	2	--	2	4	--	49	--
Trucks % of Movement	0.0%	4.3%	2.3%	1.6%	2.2%	--	0.0%	6.9%	0.8%	3.2%	3.5%	--	0.0%	1.8%	0.6%	3.3%	1.0%	--	0.0%	0.6%	0.0%	0.9%	0.5%	--	1.4%	

