

SEH CONSULTING
Traffic Data Collection
TURN MOVEMENT COUNT

TH-51 / Snelling Ave at Co.Rd.B
Ref.Pt.: 007.350
data by SEH
TURN MOVEMENT COUNT

File Name : TH-51 at CoRd B 2008
Site Code : 00000019
Start Date : 11/19/2008
Page No : 1

Groups Printed- Unshifted - Heavy Veh

Start Time	TH-51 / Snelling Ave Southbound				Co.Rd. B Westbound				TH-51 / Snelling Ave Northbound				Co.Rd. B Eastbound				Int. Total
	Left	Thru	Right	Peds	Left	Thru	Right	Peds	Left	Thru	Right	Peds	Left	Thru	Right	Peds	
06:00	5	92	9	0	6	6	5	0	0	68	5	3	1	1	4	1	206
06:15	9	136	20	0	5	4	2	0	4	84	5	0	13	8	5	0	295
06:30	6	210	14	6	11	13	14	0	4	94	14	2	11	9	7	2	417
06:45	14	294	30	0	13	18	11	0	5	141	10	0	6	7	5	1	555
Total	34	732	73	6	35	41	32	0	13	387	34	5	31	25	21	4	1473
07:00	9	310	37	0	15	19	13	0	7	136	15	0	11	15	14	2	603
07:15	17	359	66	2	14	36	11	0	7	174	14	0	16	13	13	2	744
07:30	11	383	61	18	27	69	19	0	23	230	19	0	23	17	7	2	909
07:45	21	375	82	1	31	67	21	0	32	209	17	0	22	36	13	1	928
Total	58	1427	246	21	87	191	64	0	69	749	65	0	72	81	47	7	3184
08:00	20	303	62	0	32	52	20	0	23	206	19	1	13	24	11	0	786
08:15	28	335	62	1	21	40	11	0	15	182	25	1	15	23	8	3	770
08:30	37	260	60	1	27	67	23	0	22	163	21	0	18	31	11	0	741
08:45	34	268	73	1	21	49	33	0	37	190	21	2	25	57	8	0	819
Total	119	1166	257	3	101	208	87	0	97	741	86	4	71	135	38	3	3116
*** BREAK ***																	
11:00	79	170	50	1	30	39	72	0	21	181	28	1	30	43	22	0	767
11:15	88	175	55	0	28	56	68	0	22	220	48	0	33	50	24	0	867
11:30	106	194	69	2	36	55	72	0	22	215	46	1	34	47	25	1	925
11:45	92	180	53	3	31	58	85	0	16	208	40	1	39	73	27	0	906
Total	365	719	227	6	125	208	297	0	81	824	162	3	136	213	98	1	3465
12:00	101	195	59	1	65	58	81	0	27	221	44	1	38	86	29	1	1007
12:15	97	211	64	0	47	54	84	0	39	244	45	1	40	74	27	0	1027
12:30	99	216	60	2	33	80	87	0	13	213	41	2	40	62	34	1	983
12:45	97	207	63	1	38	57	92	0	29	254	46	2	55	82	20	0	1043
Total	394	829	246	4	183	249	344	0	108	932	176	6	173	304	110	2	4060
*** BREAK ***																	
15:00	84	221	73	1	35	47	71	0	25	283	45	3	43	65	28	2	1026
15:15	75	183	52	1	38	48	75	1	26	275	53	4	42	66	40	0	979
15:30	107	232	55	1	33	42	69	3	20	357	34	3	34	74	23	1	1088
15:45	96	231	57	2	30	65	60	2	29	333	44	0	44	70	38	1	1102
Total	362	867	237	5	136	202	275	6	100	1248	176	10	163	275	129	4	4195
16:00	72	213	52	2	46	57	64	0	24	377	33	4	49	79	43	1	1116
16:15	91	268	42	2	45	57	56	3	28	354	47	6	31	75	26	3	1134
16:30	81	225	38	3	33	42	52	2	20	404	46	4	36	104	29	1	1120
16:45	88	303	52	2	35	54	56	1	42	396	52	5	25	122	25	0	1258
Total	332	1009	184	9	159	210	228	6	114	1531	178	19	141	380	123	5	4628
17:00	95	261	55	1	37	49	49	1	31	368	50	4	38	135	25	0	1199
17:15	77	334	43	1	45	51	56	0	33	420	65	4	18	112	34	4	1297
17:30	62	289	69	1	43	47	46	0	35	370	61	0	34	99	42	2	1200
17:45	103	303	54	1	44	42	42	0	38	319	55	0	31	90	29	2	1153
Total	337	1187	221	4	169	189	193	1	137	1477	231	8	121	436	130	8	4849
Grand Total	2001	7936	1691	58	995	1498	1520	13	719	7889	1108	55	908	1849	696	34	28970
Apprch %	17.1	67.9	14.5	0.5	24.7	37.2	37.8	0.3	7.4	80.7	11.3	0.6	26	53	20	1	
Total %	6.9	27.4	5.8	0.2	3.4	5.2	5.2	0	2.5	27.2	3.8	0.2	3.1	6.4	2.4	0.1	
Unshifted	1974	7800	1676	58	992	1495	1486	13	716	7767	1097	55	900	1819	688	34	28570
% Unshifted	98.7	98.3	99.1	100	99.7	99.8	97.8	100	99.6	98.5	99	100	99.1	98.4	98.9	100	98.6
Heavy Veh	27	136	15	0	3	3	34	0	3	122	11	0	8	30	8	0	400
% Heavy Veh	1.3	1.7	0.9	0	0.3	0.2	2.2	0	0.4	1.5	1	0	0.9	1.6	1.1	0	1.4

SEH CONSULTING
Traffic Data Collection
TURN MOVEMENT COUNT

TH-51 / Snelling Ave at Co.Rd.B
Ref.Pt.: 007.350
data by SEH
TURN MOVEMENT COUNT

File Name : TH-51 at CoRd B 2008
Site Code : 00000019
Start Date : 11/19/2008
Page No : 3

Start Time	TH-51 / Snelling Ave Southbound					Co.Rd. B Westbound					TH-51 / Snelling Ave Northbound					Co.Rd. B Eastbound					Int. Total
	Left	Thru	Right	Peds	App. Total	Left	Thru	Right	Peds	App. Total	Left	Thru	Right	Peds	App. Total	Left	Thru	Right	Peds	App. Total	
Peak Hour Analysis From 06:00 to 09:00 - Peak 1 of 1																					
Peak Hour for Entire Intersection Begins at 07:30																					
07:30	11	383	61	18	473	27	69	19	0	115	23	230	19	0	272	23	17	7	2	49	909
07:45	21	375	82	1	479	31	67	21	0	119	32	209	17	0	258	22	36	13	1	72	928
08:00	20	303	62	0	385	32	52	20	0	104	23	206	19	1	249	13	24	11	0	48	786
08:15	28	335	62	1	426	21	40	11	0	72	15	182	25	1	223	15	23	8	3	49	770
Total Volume	80	1396	267	20	1763	111	228	71	0	410	93	827	80	2	1002	73	100	39	6	218	3393
% App. Total	4.5	79.2	15.1	1.1		27.1	55.6	17.3	0		9.3	82.5	8	0.2		33.5	45.9	17.9	2.8		
PHF	.714	.911	.814	.278	.920	.867	.826	.845	.000	.861	.727	.899	.800	.500	.921	.793	.694	.750	.500	.757	.914

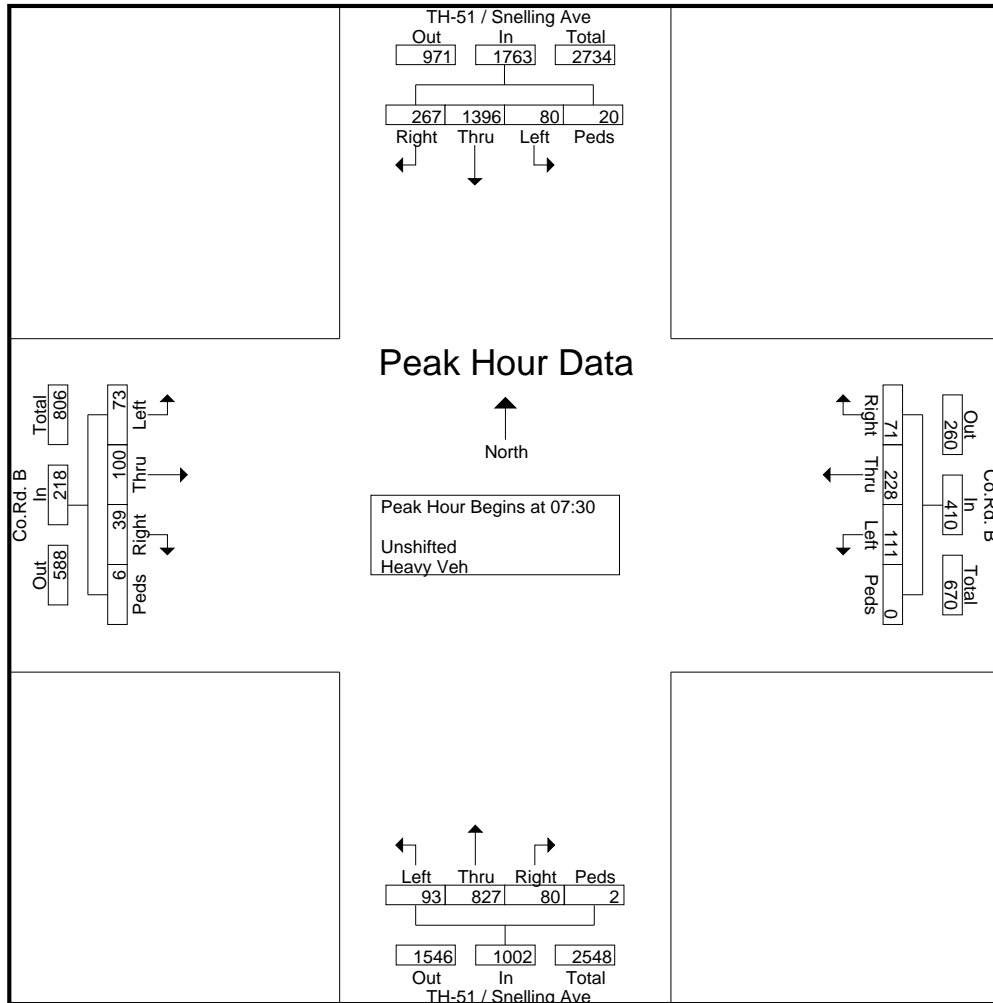

SEH CONSULTING
Traffic Data Collection
TURN MOVEMENT COUNT

TH-51 / Snelling Ave at Co.Rd.B
Ref.Pt.: 007.350
data by SEH
TURN MOVEMENT COUNT

File Name : TH-51 at CoRd B 2008
Site Code : 00000019
Start Date : 11/19/2008
Page No : 4

Start Time	TH-51 / Snelling Ave Southbound					Co.Rd. B Westbound					TH-51 / Snelling Ave Northbound					Co.Rd. B Eastbound					Int. Total
	Left	Thru	Right	Peds	App. Total	Left	Thru	Right	Peds	App. Total	Left	Thru	Right	Peds	App. Total	Left	Thru	Right	Peds	App. Total	
Peak Hour Analysis From 15:00 to 17:45 - Peak 1 of 1																					
Peak Hour for Entire Intersection Begins at 16:45																					
16:45	88	303	52	2	445	35	54	56	1	146	42	396	52	5	495	25	122	25	0	172	1258
17:00	95	261	55	1	412	37	49	49	1	136	31	368	50	4	453	38	135	25	0	198	1199
17:15	77	334	43	1	455	45	51	56	0	152	33	420	65	4	522	18	112	34	4	168	1297
17:30	62	289	69	1	421	43	47	46	0	136	35	370	61	0	466	34	99	42	2	177	1200
Total Volume	322	1187	219	5	1733	160	201	207	2	570	141	1554	228	13	1936	115	468	126	6	715	4954
% App. Total	18.6	68.5	12.6	0.3		28.1	35.3	36.3	0.4		7.3	80.3	11.8	0.7		16.1	65.5	17.6	0.8		
PHF	.847	.888	.793	.625	.952	.889	.931	.924	.500	.938	.839	.925	.877	.650	.927	.757	.867	.750	.375	.903	.955

