

Alliant Engineering, Inc.

233 Park Ave Suite 300

Minneapolis, MN 55415

--TRAFFIC DATA--

TH 55 and Rockford Road
 Ref.Pt.: 178.639
 data by : Alliant Inc.
 TURN MOVEMENT COUNT

File Name : 408_TH 55 & Rockford Rd
 Site Code : 408
 Start Date : 2/1/2018
 Page No : 1

Groups Printed- Class 1 - Class 2

| Start Time | Rockford Rd From North | | | | | TH 55 From East | | | | | Rockford Rd From South | | | | | TH 55 From West | | | | | Int. Total |
|---------------|------------------------|-------|------|------|------------|-----------------|-------|------|------|------------|------------------------|-------|------|------|------------|-----------------|-------|------|------|------------|------------|
| | Other | Right | Thru | Left | App. Total | Other | Right | Thru | Left | App. Total | Other | Right | Thru | Left | App. Total | Other | Right | Thru | Left | App. Total | |
| 06:00 AM | 0 | 10 | 29 | 7 | 46 | 0 | 1 | 58 | 15 | 74 | 0 | 20 | 17 | 2 | 39 | 0 | 5 | 246 | 9 | 260 | 419 |
| 06:15 AM | 0 | 16 | 19 | 15 | 50 | 0 | 6 | 64 | 12 | 82 | 0 | 29 | 14 | 1 | 44 | 0 | 6 | 321 | 8 | 335 | 511 |
| 06:30 AM | 0 | 25 | 27 | 15 | 67 | 0 | 3 | 108 | 14 | 125 | 0 | 25 | 34 | 3 | 62 | 0 | 2 | 394 | 17 | 413 | 667 |
| 06:45 AM | 0 | 24 | 34 | 24 | 82 | 0 | 2 | 122 | 18 | 142 | 0 | 47 | 33 | 7 | 87 | 0 | 6 | 466 | 17 | 489 | 800 |
| Total | 0 | 75 | 109 | 61 | 245 | 0 | 12 | 352 | 59 | 423 | 0 | 121 | 98 | 13 | 232 | 0 | 19 | 1427 | 51 | 1497 | 2397 |
| 07:00 AM | 0 | 14 | 29 | 25 | 68 | 0 | 3 | 126 | 36 | 165 | 0 | 49 | 39 | 4 | 92 | 0 | 12 | 538 | 14 | 564 | 889 |
| 07:15 AM | 0 | 24 | 37 | 29 | 90 | 0 | 4 | 158 | 23 | 185 | 0 | 66 | 54 | 13 | 133 | 0 | 20 | 476 | 19 | 515 | 923 |
| 07:30 AM | 0 | 24 | 69 | 32 | 125 | 0 | 3 | 187 | 30 | 220 | 0 | 73 | 92 | 17 | 182 | 0 | 20 | 496 | 19 | 535 | 1062 |
| 07:45 AM | 0 | 43 | 73 | 32 | 148 | 0 | 4 | 264 | 25 | 293 | 0 | 70 | 80 | 26 | 176 | 0 | 12 | 455 | 21 | 488 | 1105 |
| Total | 0 | 105 | 208 | 118 | 431 | 0 | 14 | 735 | 114 | 863 | 0 | 258 | 265 | 60 | 583 | 0 | 64 | 1965 | 73 | 2102 | 3979 |
| 08:00 AM | 0 | 29 | 66 | 32 | 127 | 0 | 7 | 223 | 33 | 263 | 0 | 63 | 54 | 40 | 157 | 0 | 16 | 374 | 24 | 414 | 961 |
| 08:15 AM | 0 | 34 | 88 | 21 | 143 | 0 | 11 | 130 | 32 | 173 | 0 | 58 | 61 | 13 | 132 | 0 | 16 | 431 | 25 | 472 | 920 |
| 08:30 AM | 0 | 21 | 42 | 19 | 82 | 0 | 4 | 186 | 44 | 234 | 0 | 57 | 38 | 5 | 100 | 0 | 15 | 410 | 18 | 443 | 859 |
| 08:45 AM | 0 | 30 | 54 | 23 | 107 | 0 | 5 | 130 | 31 | 166 | 0 | 56 | 52 | 6 | 114 | 0 | 23 | 344 | 24 | 391 | 778 |
| Total | 0 | 114 | 250 | 95 | 459 | 0 | 27 | 669 | 140 | 836 | 0 | 234 | 205 | 64 | 503 | 0 | 70 | 1559 | 91 | 1720 | 3518 |
| 09:00 AM | 0 | 17 | 45 | 20 | 82 | 0 | 4 | 120 | 52 | 176 | 0 | 52 | 44 | 6 | 102 | 0 | 16 | 286 | 24 | 326 | 686 |
| 09:15 AM | 0 | 18 | 35 | 14 | 67 | 0 | 8 | 91 | 30 | 129 | 0 | 51 | 33 | 13 | 97 | 0 | 12 | 277 | 20 | 309 | 602 |
| *** BREAK *** | | | | | | | | | | | | | | | | | | | | | |
| Total | 0 | 35 | 80 | 34 | 149 | 0 | 12 | 211 | 82 | 305 | 0 | 103 | 77 | 19 | 199 | 0 | 28 | 563 | 44 | 635 | 1288 |
| *** BREAK *** | | | | | | | | | | | | | | | | | | | | | |
| 10:30 AM | 0 | 23 | 29 | 11 | 63 | 0 | 6 | 106 | 37 | 149 | 0 | 64 | 34 | 8 | 106 | 0 | 4 | 156 | 11 | 171 | 489 |
| 10:45 AM | 0 | 15 | 32 | 19 | 66 | 0 | 5 | 130 | 36 | 171 | 0 | 43 | 23 | 8 | 74 | 0 | 17 | 158 | 13 | 188 | 499 |
| Total | 0 | 38 | 61 | 30 | 129 | 0 | 11 | 236 | 73 | 320 | 0 | 107 | 57 | 16 | 180 | 0 | 21 | 314 | 24 | 359 | 988 |
| 11:00 AM | 0 | 14 | 31 | 13 | 58 | 0 | 6 | 139 | 44 | 189 | 0 | 60 | 35 | 15 | 110 | 0 | 15 | 202 | 14 | 231 | 588 |
| 11:15 AM | 0 | 20 | 39 | 8 | 67 | 0 | 11 | 151 | 45 | 207 | 0 | 58 | 31 | 19 | 108 | 0 | 15 | 232 | 11 | 258 | 640 |
| 11:30 AM | 0 | 18 | 44 | 14 | 76 | 0 | 3 | 156 | 83 | 242 | 0 | 68 | 31 | 14 | 113 | 0 | 22 | 187 | 17 | 226 | 657 |
| 11:45 AM | 0 | 19 | 41 | 13 | 73 | 0 | 7 | 172 | 77 | 256 | 0 | 69 | 37 | 13 | 119 | 0 | 22 | 199 | 10 | 231 | 679 |
| Total | 0 | 71 | 155 | 48 | 274 | 0 | 27 | 618 | 249 | 894 | 0 | 255 | 134 | 61 | 450 | 0 | 74 | 820 | 52 | 946 | 2564 |
| 12:00 PM | 0 | 19 | 53 | 8 | 80 | 0 | 8 | 171 | 84 | 263 | 0 | 52 | 42 | 17 | 111 | 0 | 20 | 195 | 21 | 236 | 690 |
| 12:15 PM | 0 | 19 | 50 | 7 | 76 | 0 | 39 | 180 | 55 | 274 | 0 | 55 | 42 | 21 | 118 | 0 | 17 | 193 | 17 | 227 | 695 |
| 12:30 PM | 0 | 30 | 39 | 18 | 87 | 0 | 11 | 160 | 78 | 249 | 0 | 58 | 41 | 21 | 120 | 0 | 17 | 175 | 13 | 205 | 661 |
| 12:45 PM | 0 | 28 | 43 | 11 | 82 | 0 | 8 | 181 | 73 | 262 | 0 | 60 | 35 | 24 | 119 | 0 | 19 | 167 | 15 | 201 | 664 |
| Total | 0 | 96 | 185 | 44 | 325 | 0 | 66 | 692 | 290 | 1048 | 0 | 225 | 160 | 83 | 468 | 0 | 73 | 730 | 66 | 869 | 2710 |
| 01:00 PM | 0 | 18 | 38 | 9 | 65 | 0 | 6 | 198 | 79 | 283 | 0 | 78 | 35 | 22 | 135 | 0 | 14 | 145 | 10 | 169 | 652 |
| 01:15 PM | 0 | 18 | 38 | 5 | 61 | 0 | 5 | 181 | 58 | 244 | 0 | 82 | 32 | 19 | 133 | 0 | 10 | 156 | 19 | 185 | 623 |
| *** BREAK *** | | | | | | | | | | | | | | | | | | | | | |
| Total | 0 | 36 | 76 | 14 | 126 | 0 | 11 | 379 | 137 | 527 | 0 | 160 | 67 | 41 | 268 | 0 | 24 | 301 | 29 | 354 | 1275 |
| *** BREAK *** | | | | | | | | | | | | | | | | | | | | | |
| 02:30 PM | 0 | 26 | 44 | 11 | 81 | 0 | 12 | 227 | 56 | 295 | 0 | 52 | 57 | 14 | 123 | 0 | 15 | 172 | 16 | 203 | 702 |
| 02:45 PM | 0 | 25 | 61 | 14 | 100 | 0 | 15 | 253 | 60 | 328 | 0 | 61 | 41 | 21 | 123 | 0 | 14 | 158 | 17 | 189 | 740 |
| Total | 0 | 51 | 105 | 25 | 181 | 0 | 27 | 480 | 116 | 623 | 0 | 113 | 98 | 35 | 246 | 0 | 29 | 330 | 33 | 392 | 1442 |
| 03:00 PM | 0 | 20 | 47 | 6 | 73 | 0 | 11 | 324 | 47 | 382 | 0 | 60 | 39 | 14 | 113 | 0 | 18 | 172 | 14 | 204 | 772 |
| 03:15 PM | 0 | 24 | 57 | 5 | 86 | 0 | 9 | 314 | 71 | 394 | 0 | 55 | 61 | 18 | 134 | 0 | 31 | 248 | 17 | 296 | 910 |
| 03:30 PM | 0 | 37 | 49 | 12 | 98 | 0 | 12 | 389 | 55 | 456 | 0 | 76 | 54 | 21 | 151 | 0 | 29 | 259 | 19 | 307 | 1012 |
| 03:45 PM | 0 | 39 | 48 | 11 | 98 | 0 | 9 | 440 | 68 | 517 | 0 | 59 | 30 | 12 | 101 | 0 | 16 | 219 | 17 | 252 | 968 |
| Total | 0 | 120 | 201 | 34 | 355 | 0 | 41 | 1467 | 241 | 1749 | 0 | 250 | 184 | 65 | 499 | 0 | 94 | 898 | 67 | 1059 | 3662 |
| 04:00 PM | 0 | 39 | 65 | 11 | 115 | 0 | 15 | 456 | 74 | 545 | 0 | 55 | 43 | 9 | 107 | 0 | 15 | 230 | 10 | 255 | 1022 |
| 04:15 PM | 0 | 36 | 77 | 11 | 124 | 0 | 32 | 469 | 80 | 581 | 0 | 56 | 49 | 26 | 131 | 0 | 22 | 194 | 30 | 246 | 1082 |
| 04:30 PM | 0 | 45 | 63 | 16 | 124 | 0 | 11 | 501 | 103 | 615 | 0 | 66 | 52 | 31 | 149 | 0 | 20 | 212 | 25 | 257 | 1145 |

Alliant Engineering, Inc.

233 Park Ave Suite 300

Minneapolis, MN 55415

--TRAFFIC DATA--

File Name : 408_TH 55 & Rockford Rd

Site Code : 408

Start Date : 2/1/2018

Page No : 2

Groups Printed- Class 1 - Class 2

| Start Time | Rockford Rd From North | | | | | TH 55 From East | | | | | Rockford Rd From South | | | | | TH 55 From West | | | | | Int. Total |
|-------------|---------------------------|------|------|------|------------|--------------------|------|------|------|------------|---------------------------|------|------|------|------------|--------------------|------|-------|------|------------|------------|
| | Other | Rght | Thru | Left | App. Total | Other | Rght | Thru | Left | App. Total | Other | Rght | Thru | Left | App. Total | Other | Rght | Thru | Left | App. Total | |
| 04:45 PM | 0 | 27 | 72 | 8 | 107 | 0 | 20 | 489 | 68 | 577 | 0 | 63 | 42 | 29 | 134 | 0 | 15 | 229 | 28 | 272 | 1090 |
| Total | 0 | 147 | 277 | 46 | 470 | 0 | 78 | 1915 | 325 | 2318 | 0 | 240 | 186 | 95 | 521 | 0 | 72 | 865 | 93 | 1030 | 4339 |
| 05:00 PM | 0 | 37 | 71 | 9 | 117 | 0 | 21 | 460 | 85 | 566 | 0 | 63 | 51 | 30 | 144 | 0 | 24 | 230 | 22 | 276 | 1103 |
| 05:15 PM | 0 | 47 | 101 | 15 | 163 | 0 | 18 | 484 | 100 | 602 | 0 | 55 | 79 | 31 | 165 | 0 | 26 | 218 | 17 | 261 | 1191 |
| 05:30 PM | 0 | 42 | 85 | 13 | 140 | 0 | 29 | 441 | 111 | 581 | 0 | 56 | 55 | 25 | 136 | 0 | 28 | 221 | 30 | 279 | 1136 |
| 05:45 PM | 0 | 19 | 68 | 6 | 93 | 0 | 18 | 354 | 88 | 460 | 0 | 56 | 44 | 31 | 131 | 0 | 21 | 213 | 16 | 250 | 934 |
| Total | 0 | 145 | 325 | 43 | 513 | 0 | 86 | 1739 | 384 | 2209 | 0 | 230 | 229 | 117 | 576 | 0 | 99 | 882 | 85 | 1066 | 4364 |
| Grand Total | 0 | 1033 | 2032 | 592 | 3657 | 0 | 412 | 9493 | 2210 | 12115 | 0 | 2296 | 1760 | 669 | 4725 | 0 | 667 | 10654 | 708 | 12029 | 32526 |
| Apprch % | 0 | 28.2 | 55.6 | 16.2 | | 0 | 3.4 | 78.4 | 18.2 | | 0 | 48.6 | 37.2 | 14.2 | | 0 | 5.5 | 88.6 | 5.9 | | |
| Total % | 0 | 3.2 | 6.2 | 1.8 | 11.2 | 0 | 1.3 | 29.2 | 6.8 | 37.2 | 0 | 7.1 | 5.4 | 2.1 | 14.5 | 0 | 2.1 | 32.8 | 2.2 | 37 | |
| Class 1 | 0 | 1000 | 1965 | 572 | 3537 | 0 | 392 | 9124 | 2090 | 11606 | 0 | 2201 | 1721 | 657 | 4579 | 0 | 656 | 10323 | 688 | 11667 | 31389 |
| % Class 1 | 0 | 96.8 | 96.7 | 96.6 | 96.7 | 0 | 95.1 | 96.1 | 94.6 | 95.8 | 0 | 95.9 | 97.8 | 98.2 | 96.9 | 0 | 98.4 | 96.9 | 97.2 | 97 | 96.5 |
| Class 2 | 0 | 33 | 67 | 20 | 120 | 0 | 20 | 369 | 120 | 509 | 0 | 95 | 39 | 12 | 146 | 0 | 11 | 331 | 20 | 362 | 1137 |
| % Class 2 | 0 | 3.2 | 3.3 | 3.4 | 3.3 | 0 | 4.9 | 3.9 | 5.4 | 4.2 | 0 | 4.1 | 2.2 | 1.8 | 3.1 | 0 | 1.6 | 3.1 | 2.8 | 3 | 3.5 |

Alliant Engineering, Inc.

233 Park Ave Suite 300

Minneapolis, MN 55415

--TRAFFIC DATA--

File Name : 408_TH 55 & Rockford Rd

Site Code : 408

Start Date : 2/1/2018

Page No : 3

| Start Time | Rockford Rd From North | | | | | TH 55 From East | | | | | Rockford Rd From South | | | | | TH 55 From West | | | | | Int. Total |
|--|------------------------|------|------|------|------------|-----------------|------|------|------|------------|------------------------|------|------|------|------------|-----------------|------|------|------|------------|------------|
| | Other | Rght | Thru | Left | App. Total | Other | Rght | Thru | Left | App. Total | Other | Rght | Thru | Left | App. Total | Other | Rght | Thru | Left | App. Total | |
| Peak Hour Analysis From 06:00 AM to 11:45 AM - Peak 1 of 1 | | | | | | | | | | | | | | | | | | | | | |
| Peak Hour for Entire Intersection Begins at 07:15 AM | | | | | | | | | | | | | | | | | | | | | |
| 07:15 AM | 0 | 24 | 37 | 29 | 90 | 0 | 4 | 158 | 23 | 185 | 0 | 66 | 54 | 13 | 133 | 0 | 20 | 476 | 19 | 515 | 923 |
| 07:30 AM | 0 | 24 | 69 | 32 | 125 | 0 | 3 | 187 | 30 | 220 | 0 | 73 | 92 | 17 | 182 | 0 | 20 | 496 | 19 | 535 | 1062 |
| 07:45 AM | 0 | 43 | 73 | 32 | 148 | 0 | 4 | 264 | 25 | 293 | 0 | 70 | 80 | 26 | 176 | 0 | 12 | 455 | 21 | 488 | 1105 |
| 08:00 AM | 0 | 29 | 66 | 32 | 127 | 0 | 7 | 223 | 33 | 263 | 0 | 63 | 54 | 40 | 157 | 0 | 16 | 374 | 24 | 414 | 961 |
| Total Volume | 0 | 120 | 245 | 125 | 490 | 0 | 18 | 832 | 111 | 961 | 0 | 272 | 280 | 96 | 648 | 0 | 68 | 1801 | 83 | 1952 | 4051 |
| % App. Total | 0 | 24.5 | 50 | 25.5 | | 0 | 1.9 | 86.6 | 11.6 | | 0 | 42 | 43.2 | 14.8 | | 0 | 3.5 | 92.3 | 4.3 | | |
| PHF | .000 | .698 | .839 | .977 | .828 | .000 | .643 | .788 | .841 | .820 | .000 | .932 | .761 | .600 | .890 | .000 | .850 | .908 | .865 | .912 | .917 |

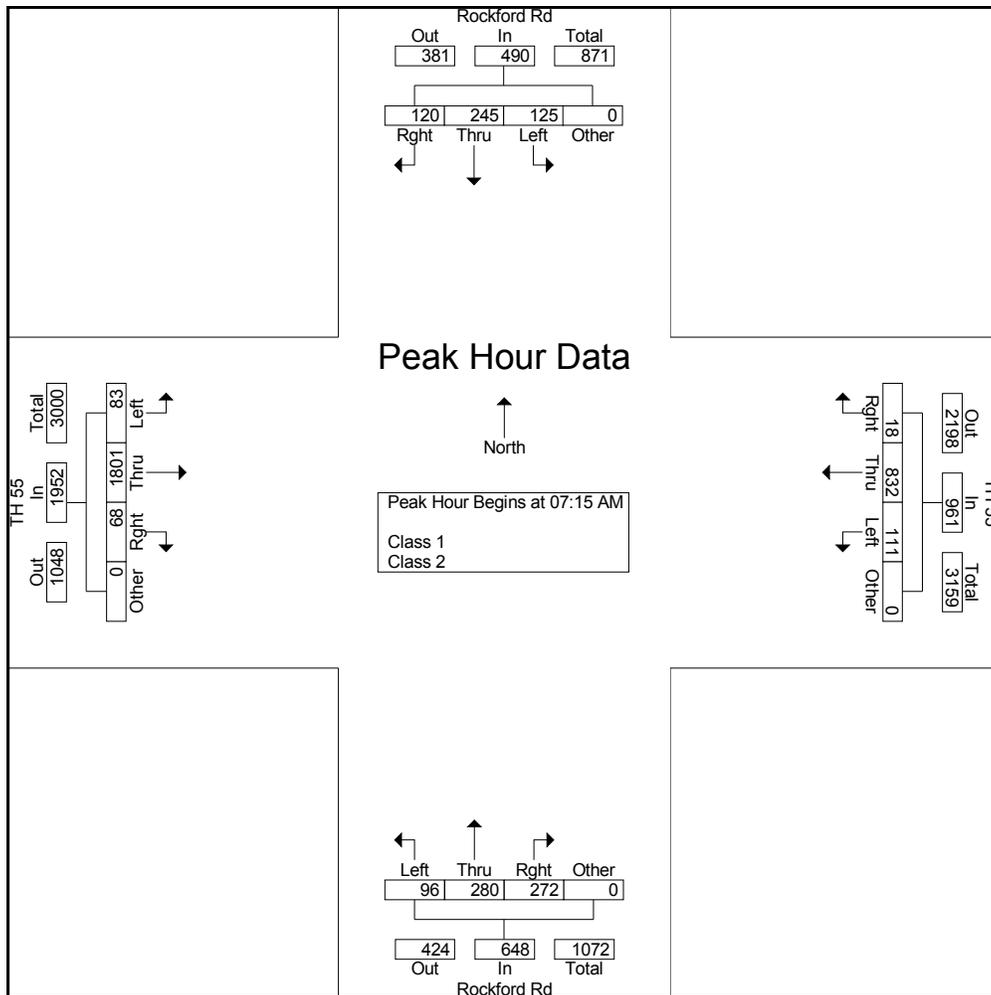

Alliant Engineering, Inc.

233 Park Ave Suite 300
 Minneapolis, MN 55415
 --TRAFFIC DATA--

File Name : 408_TH 55 & Rockford Rd
 Site Code : 408
 Start Date : 2/1/2018
 Page No : 4

| Start Time | Rockford Rd From North | | | | | TH 55 From East | | | | | Rockford Rd From South | | | | | TH 55 From West | | | | | Int. Total |
|--|------------------------|-------|-------|------|------------|-----------------|-------|-------|------|------------|------------------------|-------|-------|------|------------|-----------------|-------|-------|------|------------|------------|
| | Other | Rgh t | Thr u | Left | App. Total | Other | Rgh t | Thr u | Left | App. Total | Other | Rgh t | Thr u | Left | App. Total | Other | Rgh t | Thr u | Left | App. Total | |
| Peak Hour Analysis From 12:00 PM to 05:45 PM - Peak 1 of 1 | | | | | | | | | | | | | | | | | | | | | |
| Peak Hour for Entire Intersection Begins at 04:30 PM | | | | | | | | | | | | | | | | | | | | | |
| 04:30 PM | 0 | 45 | 63 | 16 | 124 | 0 | 11 | 501 | 103 | 615 | 0 | 66 | 52 | 31 | 149 | 0 | 20 | 212 | 25 | 257 | 1145 |
| 04:45 PM | 0 | 27 | 72 | 8 | 107 | 0 | 20 | 489 | 68 | 577 | 0 | 63 | 42 | 29 | 134 | 0 | 15 | 229 | 28 | 272 | 1090 |
| 05:00 PM | 0 | 37 | 71 | 9 | 117 | 0 | 21 | 460 | 85 | 566 | 0 | 63 | 51 | 30 | 144 | 0 | 24 | 230 | 22 | 276 | 1103 |
| 05:15 PM | 0 | 47 | 101 | 15 | 163 | 0 | 18 | 484 | 100 | 602 | 0 | 55 | 79 | 31 | 165 | 0 | 26 | 218 | 17 | 261 | 1191 |
| Total Volume | 0 | 156 | 307 | 48 | 511 | 0 | 70 | 1934 | 356 | 2360 | 0 | 247 | 224 | 121 | 592 | 0 | 85 | 889 | 92 | 1066 | 4529 |
| % App. Total | 0 | 30.5 | 60.1 | 9.4 | | 0 | 3 | 81.9 | 15.1 | | 0 | 41.7 | 37.8 | 20.4 | | 0 | 8 | 83.4 | 8.6 | | |
| PHF | .000 | .830 | .760 | .750 | .784 | .000 | .833 | .965 | .864 | .959 | .000 | .936 | .709 | .976 | .897 | .000 | .817 | .966 | .821 | .966 | .951 |

