



MINNESOTA DEPT OF TRANSPORTATION

TRAFFIC DATA COLLECTION - METRO

TH-62 at Gleason Rd EDINA
 Ref.Pt.: 10-6.473
 video RE
 TURN MOVEMENT COUNT

File Name : TH-62 South Ramps at Gleason Rd 2013
 Site Code :
 Start Date : 7/25/2013
 Page No : 1

Groups Printed- Cars +

Start Time	Gleason Rd Southbound				ramp to TH-62 EB Westbound				Gleason Rd Northbound				ramp from TH-62 EB Eastbound				Int. Total
	Right	Thru	Left	Peds	Right	Thru	Left	Peds	Right	Thru	Left	Peds	Right	Thru	Left	Peds	
06:00	0	2	7	0	0	0	0	3	7	10	0	0	1	0	4	4	38
06:15	0	7	13	0	0	0	0	2	8	6	0	0	8	0	8	4	56
06:30	0	9	15	0	0	0	0	2	16	15	0	0	5	0	15	1	78
06:45	0	25	25	0	0	0	0	4	19	19	0	0	28	13	30	4	167
Total	0	43	60	0	0	0	0	11	50	50	0	0	42	13	57	13	339
07:00	0	32	17	0	0	0	0	2	20	24	0	0	31	21	38	4	189
07:15	0	26	22	0	0	0	0	4	13	43	0	0	44	45	57	3	257
07:30	0	32	19	0	0	0	0	2	13	43	0	0	38	17	51	3	218
07:45	0	62	19	0	0	0	0	2	21	50	0	0	28	3	34	1	220
Total	0	152	77	0	0	0	0	10	67	160	0	0	141	86	180	11	884
08:00	0	35	24	0	0	0	0	3	17	64	0	0	18	3	29	4	197
08:15	0	46	19	0	0	0	0	4	34	44	0	0	26	8	45	2	228
08:30	0	39	16	0	0	0	0	5	19	62	4	0	31	10	45	0	231
08:45	0	58	22	0	0	0	0	5	21	65	0	0	32	2	33	1	239
Total	0	178	81	0	0	0	0	17	91	235	4	0	107	23	152	7	895
*****BREAK*****																	
15:00	0	38	8	0	0	0	0	0	14	46	0	0	43	22	69	0	240
15:15	0	35	12	0	0	0	0	2	10	45	0	0	61	22	58	0	245
15:30	0	48	8	0	0	0	0	2	4	55	0	0	71	54	91	0	333
15:45	0	43	13	0	0	0	0	4	4	59	0	0	72	40	76	0	311
Total	0	164	41	0	0	0	0	8	32	205	0	0	247	138	294	0	1129
16:00	0	53	18	0	0	0	0	1	14	72	0	0	111	51	79	3	402
16:15	0	69	18	0	0	0	0	4	10	74	0	0	84	45	98	1	403
16:30	0	83	25	0	0	0	0	1	5	76	0	0	82	39	89	1	401
16:45	0	85	11	0	0	0	0	1	10	101	0	0	125	42	78	1	454
Total	0	290	72	0	0	0	0	7	39	323	0	0	402	177	344	6	1660
17:00	0	63	25	0	0	0	0	3	3	107	1	0	78	25	64	1	370
17:15	0	87	19	0	0	0	0	3	6	72	0	0	91	34	85	0	397
17:30	0	59	13	0	0	0	0	3	10	89	0	0	69	23	101	0	367
17:45	0	64	15	0	0	0	0	1	12	64	0	0	39	6	64	0	265
Total	0	273	72	0	0	0	0	10	31	332	1	0	277	88	314	1	1399
Grand Total	0	1100	403	0	0	0	0	63	310	1305	5	0	1216	525	1341	38	6306
Apprch %	0	73.2	26.8	0	0	0	0	100	19.1	80.6	0.3	0	39	16.8	43	1.2	
Total %	0	17.4	6.4	0	0	0	0	1	4.9	20.7	0.1	0	19.3	8.3	21.3	0.6	



MINNESOTA DEPT OF TRANSPORTATION

TRAFFIC DATA COLLECTION - METRO

TH-62 at Gleason Rd EDINA
 Ref.Pt.: 10-6.473
 video RE
 TURN MOVEMENT COUNT

File Name : TH-62 South Ramps at Gleason Rd 2013
 Site Code :
 Start Date : 7/25/2013
 Page No : 2

Start Time	Gleason Rd Southbound					ramp to TH-62 EB Westbound					Gleason Rd Northbound					ramp from TH-62 EB Eastbound					Int. Total
	Right	Thru	Left	Peds	App. Total	Right	Thru	Left	Peds	App. Total	Right	Thru	Left	Peds	App. Total	Right	Thru	Left	Peds	App. Total	
Peak Hour Analysis From 06:00 to 08:45 - Peak 1 of 1																					
Peak Hour for Entire Intersection Begins at 08:00																					
08:00	0	35	24	0	59	0	0	0	3	3	17	64	0	0	81	18	3	29	4	54	197
08:15	0	46	19	0	65	0	0	0	4	4	34	44	0	0	78	26	8	45	2	81	228
08:30	0	39	16	0	55	0	0	0	5	5	19	62	4	0	85	31	10	45	0	86	231
08:45	0	58	22	0	80	0	0	0	5	5	21	65	0	0	86	32	2	33	1	68	239
Total Volume	0	178	81	0	259	0	0	0	17	17	91	235	4	0	330	107	23	152	7	289	895
% App. Total	0	68.7	31.3	0		0	0	0	100		27.6	71.2	1.2	0		37	8	52.6	2.4		
PHF	.000	.767	.844	.000	.809	.000	.000	.000	.850	.850	.669	.904	.250	.000	.959	.836	.575	.844	.438	.840	.936

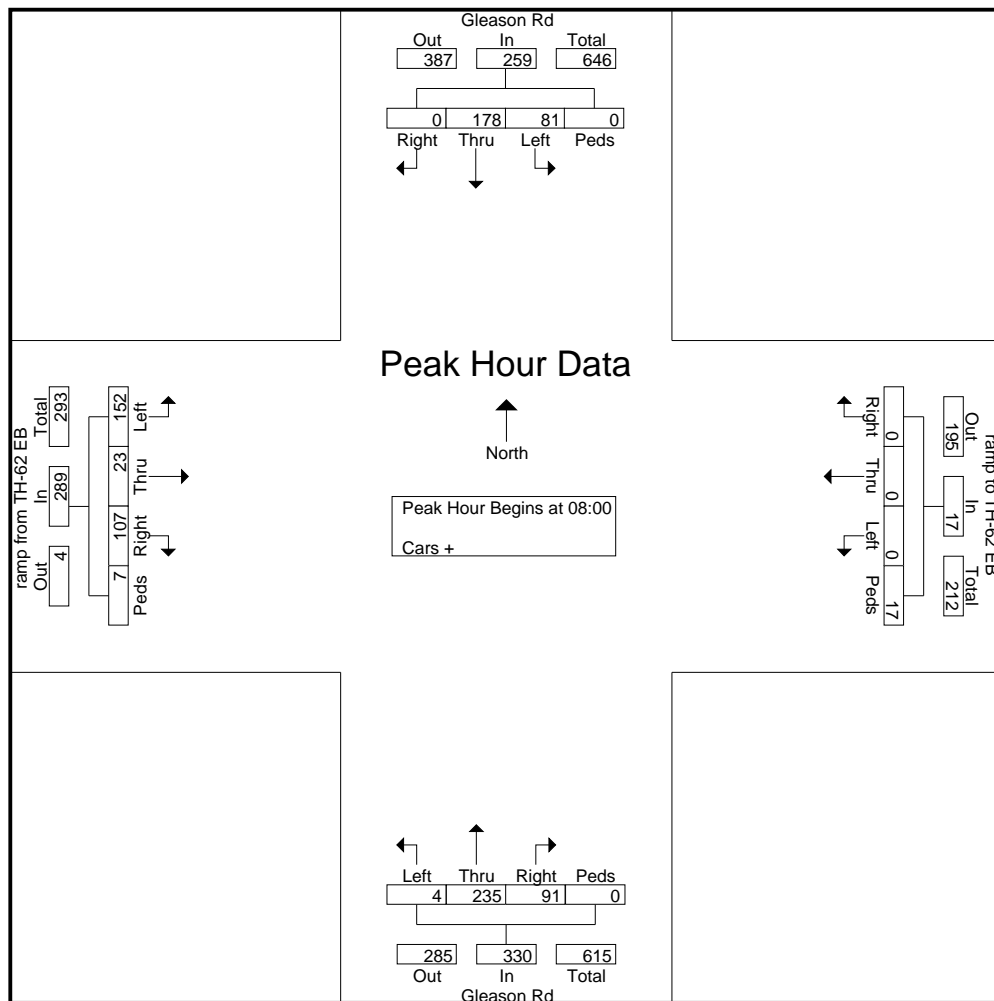



MINNESOTA DEPT OF TRANSPORTATION

TRAFFIC DATA COLLECTION - METRO

TH-62 at Gleason Rd EDINA
 Ref.Pt.: 10-6.473
 video RE
 TURN MOVEMENT COUNT

File Name : TH-62 South Ramps at Gleason Rd 2013
 Site Code :
 Start Date : 7/25/2013
 Page No : 3

Start Time	Gleason Rd Southbound					ramp to TH-62 EB Westbound					Gleason Rd Northbound					ramp from TH-62 EB Eastbound					Int. Total
	Right	Thru	Left	Peds	App. Total	Right	Thru	Left	Peds	App. Total	Right	Thru	Left	Peds	App. Total	Right	Thru	Left	Peds	App. Total	
Peak Hour Analysis From 15:00 to 17:45 - Peak 1 of 1																					
Peak Hour for Entire Intersection Begins at 16:00																					
16:00	0	53	18	0	71	0	0	0	1	1	14	72	0	0	86	111	51	79	3	244	402
16:15	0	69	18	0	87	0	0	0	4	4	10	74	0	0	84	84	45	98	1	228	403
16:30	0	83	25	0	108	0	0	0	1	1	5	76	0	0	81	82	39	89	1	211	401
16:45	0	85	11	0	96	0	0	0	1	1	10	101	0	0	111	125	42	78	1	246	454
Total Volume	0	290	72	0	362	0	0	0	7	7	39	323	0	0	362	402	177	344	6	929	1660
% App. Total	0	80.1	19.9	0		0	0	0	100		10.8	89.2	0	0		43.3	19.1	37	0.6		
PHF	.000	.853	.720	.000	.838	.000	.000	.000	.438	.438	.696	.800	.000	.000	.815	.804	.868	.878	.500	.944	.914

