



MINNESOTA DEPT OF TRANSPORTATION

TRAFFIC DATA COLLECTION - METRO

TH-65 / Central Ave NE at 52nd Ave NE

File Name : TH-65 at 52nd Ave NE 2009

Ref.Pt.: 005991

Site Code : 00000000

JAMAR # 631/632/336

RE/DR/CH

Start Date : 5/6/2009

TURN MOVEMENT COUNT

Page No : 1

Groups Printed- Cars & Trucks

Start Time	TH-65 / CENTRAL AVE NE Southbound				52nd Ave NE Westbound				TH-65 / CENTRAL AVE NE Northbound				52nd Ave NE Eastbound				Int. Total
	Left	Thru	Right	Peds	Left	Thru	Right	Peds	Left	Thru	Right	Peds	Left	Thru	Right	Peds	
06:00	2	109	0	0	2	0	5	0	0	80	1	2	2	0	0	0	203
06:15	2	156	0	0	2	0	10	0	1	104	3	1	0	0	1	2	282
06:30	2	212	0	0	5	0	7	0	3	162	3	1	0	0	0	0	395
06:45	2	202	1	0	4	0	10	0	2	144	2	0	0	0	1	0	368
Total	8	679	1	0	13	0	32	0	6	490	9	4	2	0	2	2	1248
07:00	2	247	0	0	3	1	8	0	1	132	1	0	1	2	1	1	400
07:15	6	267	0	0	8	0	4	0	0	178	5	0	0	0	3	0	471
07:30	4	267	0	0	9	0	17	0	4	231	4	0	2	0	1	0	539
07:45	7	320	2	0	7	1	15	0	7	237	7	1	1	0	1	2	608
Total	19	1101	2	0	27	2	44	0	12	778	17	1	4	2	6	3	2018
08:00	6	274	1	0	2	0	15	0	5	181	4	0	1	0	2	0	491
08:15	5	193	0	0	1	1	6	0	4	160	8	1	2	0	0	0	381
08:30	13	216	1	0	7	0	14	0	6	194	3	1	2	0	2	0	459
08:45	11	191	1	0	9	0	14	0	5	164	7	0	2	1	1	0	406
Total	35	874	3	0	19	1	49	0	20	699	22	2	7	1	5	0	1737
15:00	6	270	1	2	8	1	21	1	42	296	20	4	2	1	8	1	684
15:15	17	280	1	1	11	2	18	0	6	329	11	1	3	1	8	1	690
15:30	16	268	1	1	13	0	12	0	5	334	14	1	5	0	10	0	680
15:45	17	297	0	2	7	0	10	2	10	370	17	1	1	0	6	1	741
Total	56	1115	3	6	39	3	61	3	63	1329	62	7	11	2	32	3	2795
16:00	14	308	1	4	12	3	15	1	6	351	27	1	3	0	5	0	751
16:15	19	312	1	1	15	0	19	1	9	358	15	1	3	0	9	1	764
16:30	9	307	1	0	10	0	12	0	11	398	26	0	8	0	9	0	791
16:45	20	304	1	3	14	3	13	3	11	352	14	2	4	1	5	0	750
Total	62	1231	4	8	51	6	59	5	37	1459	82	4	18	1	28	1	3056
17:00	8	311	0	1	7	1	9	4	3	439	16	2	2	1	5	0	809
17:15	18	318	0	2	19	0	17	1	3	343	19	4	5	0	1	0	750
17:30	7	275	0	0	10	1	16	1	10	309	23	1	3	1	4	1	662
17:45	10	327	0	0	8	0	19	0	9	341	18	0	2	0	6	0	740
Total	43	1231	0	3	44	2	61	6	25	1432	76	7	12	2	16	1	2961
Grand Total	223	6231	13	17	193	14	306	14	163	6187	268	25	54	8	89	10	13815
Apprch %	3.4	96.1	0.2	0.3	36.6	2.7	58.1	2.7	2.5	93.1	4	0.4	33.5	5	55.3	6.2	
Total %	1.6	45.1	0.1	0.1	1.4	0.1	2.2	0.1	1.2	44.8	1.9	0.2	0.4	0.1	0.6	0.1	



MINNESOTA DEPT OF TRANSPORTATION

TRAFFIC DATA COLLECTION - METRO

TH-65 / Central Ave NE at 52nd Ave NE

Ref.Pt.: 005991

JAMAR # 631/632/336

RE/DR/CH

TURN MOVEMENT COUNT

File Name : TH-65 at 52nd Ave NE 2009

Site Code : 00000000

Start Date : 5/6/2009

Page No : 2

Start Time	TH-65 / CENTRAL AVE NE Southbound					52nd Ave NE Westbound					TH-65 / CENTRAL AVE NE Northbound					52nd Ave NE Eastbound					Int. Total
	Left	Thru	Right	Peds	App. Total	Left	Thru	Right	Peds	App. Total	Left	Thru	Right	Peds	App. Total	Left	Thru	Right	Peds	App. Total	
Peak Hour Analysis From 06:00 to 08:45 - Peak 1 of 1																					
Peak Hour for Entire Intersection Begins at 07:15																					
07:15	6	267	0	0	273	8	0	4	0	12	0	178	5	0	183	0	0	3	0	3	471
07:30	4	267	0	0	271	9	0	17	0	26	4	231	4	0	239	2	0	1	0	3	539
07:45	7	320	2	0	329	7	1	15	0	23	7	237	7	1	252	1	0	1	2	4	608
08:00	6	274	1	0	281	2	0	15	0	17	5	181	4	0	190	1	0	2	0	3	491
Total Volume	23	1128	3	0	1154	26	1	51	0	78	16	827	20	1	864	4	0	7	2	13	2109
% App. Total	2	97.7	0.3	0		33.3	1.3	65.4	0		1.9	95.7	2.3	0.1		30.8	0	53.8	15.4		
PHF	.821	.881	.375	.000	.877	.722	.250	.750	.000	.750	.571	.872	.714	.250	.857	.500	.000	.583	.250	.813	.867

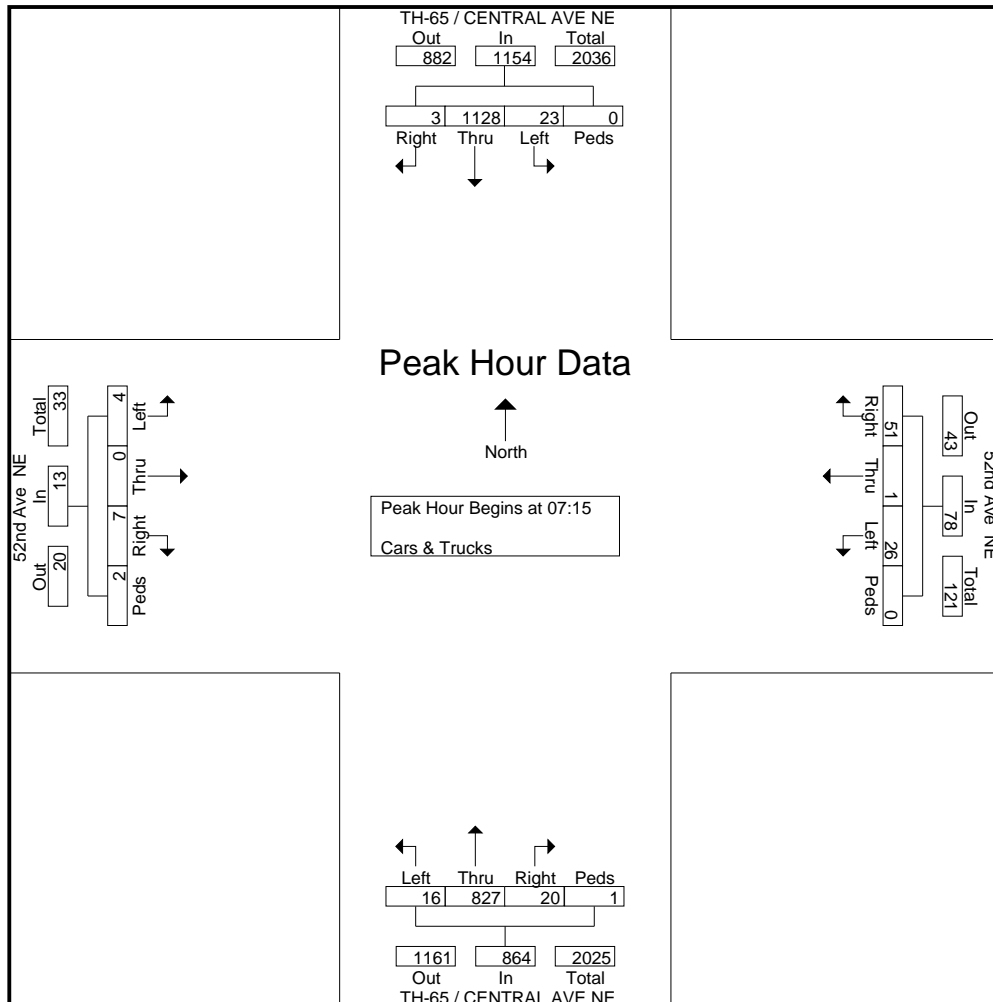



MINNESOTA DEPT OF TRANSPORTATION

TRAFFIC DATA COLLECTION - METRO

TH-65 / Central Ave NE at 52nd Ave NE

File Name : TH-65 at 52nd Ave NE 2009

Ref.Pt.: 005991

Site Code : 00000000

JAMAR # 631/632/336

RE/DR/CH

Start Date : 5/6/2009

TURN MOVEMENT COUNT

Page No : 3

Start Time	TH-65 / CENTRAL AVE NE Southbound					52nd Ave NE Westbound					TH-65 / CENTRAL AVE NE Northbound					52nd Ave NE Eastbound					Int. Total
	Left	Thru	Right	Peds	App. Total	Left	Thru	Right	Peds	App. Total	Left	Thru	Right	Peds	App. Total	Left	Thru	Right	Peds	App. Total	
16:15	19	312	1	1	333	15	0	19	1	35	9	358	15	1	383	3	0	9	1	13	764
16:30	9	307	1	0	317	10	0	12	0	22	11	398	26	0	435	8	0	9	0	17	791
16:45	20	304	1	3	328	14	3	13	3	33	11	352	14	2	379	4	1	5	0	10	750
17:00	8	311	0	1	320	7	1	9	4	21	3	439	16	2	460	2	1	5	0	8	809
Total Volume	56	1234	3	5	1298	46	4	53	8	111	34	1547	71	5	1657	17	2	28	1	48	3114
% App. Total	4.3	95.1	0.2	0.4		41.4	3.6	47.7	7.2		2.1	93.4	4.3	0.3		35.4	4.2	58.3	2.1		
PHF	.700	.989	.750	.417	.974	.767	.333	.697	.500	.793	.773	.881	.683	.625	.901	.531	.500	.778	.250	.706	.962

Peak Hour Analysis From 15:00 to 17:45 - Peak 1 of 1
 Peak Hour for Entire Intersection Begins at 16:15

