

# Alliant Engineering Inc Minneapolis, MN 55415

TH-65 at Medtronic Pkwy / Central Ave NE  
Ref.Pt.: 006.636 FRIDLEY  
data by Alliant Engineering Inc  
TURN MOVEMENT COUNT

File Name : TH-65 at Medtronic Pkwy-Central Ave 2009  
Site Code : 00000003  
Start Date : 1/6/2009  
Page No : 1

### Groups Printed- Unshifted

Start Time	TH-65 / Central Ave Southbound				Central Ave NE Westbound				TH-65 / Central Ave Northbound				Medtronic Pkwy Eastbound				Int. Total
	Left	Thru	Right	Peds	Left	Thru	Right	Peds	Left	Thru	Right	Peds	Left	Thru	Right	Peds	
06:00	5	249	2	0	51	2	5	0	7	85	20	0	0	0	2	0	428
06:15	3	285	2	0	49	3	1	0	10	111	36	0	2	2	0	0	504
06:30	9	379	4	0	83	4	4	0	7	181	66	0	2	7	0	0	746
06:45	15	350	6	0	67	5	3	0	26	174	68	0	0	8	0	0	722
Total	32	1263	14	0	250	14	13	0	50	551	190	0	4	17	2	0	2400
07:00	43	347	1	0	96	21	2	0	31	199	119	0	1	10	2	0	872
07:15	43	414	3	0	94	17	2	0	28	184	101	0	4	3	0	0	893
07:30	20	435	17	0	99	31	10	0	30	206	77	0	5	8	0	0	938
07:45	21	378	23	0	92	30	5	0	100	179	87	0	5	10	0	0	930
Total	127	1574	44	0	381	99	19	0	189	768	384	0	15	31	2	0	3633
08:00	12	299	16	0	87	28	2	1	71	189	76	0	11	8	0	0	800
08:15	4	282	16	0	71	6	3	0	56	173	62	0	3	5	0	0	681
08:30	14	306	8	0	82	12	6	0	37	185	50	0	2	7	0	0	709
08:45	13	223	8	0	59	5	3	0	26	222	49	0	7	5	0	0	620
Total	43	1110	48	0	299	51	14	1	190	769	237	0	23	25	0	0	2810
09:00	11	229	2	0	74	5	7	0	10	167	54	0	2	4	0	0	565
09:15	10	186	2	0	35	6	4	0	10	202	52	0	3	6	1	0	517
*** BREAK ***																	
Total	21	415	4	0	109	11	11	0	20	369	106	0	5	10	1	0	1082
*** BREAK ***																	
10:30	14	197	2	0	49	7	4	0	5	165	34	0	1	5	3	0	486
10:45	2	204	2	0	49	3	5	0	5	208	41	0	2	2	7	0	530
Total	16	401	4	0	98	10	9	0	10	373	75	0	3	7	10	0	1016
11:00	4	190	3	0	52	7	4	0	8	161	40	0	3	4	6	0	482
11:15	6	167	5	0	52	6	3	0	13	217	23	0	3	5	6	0	506
11:30	4	183	6	0	60	7	3	0	7	225	37	0	8	7	6	0	553
11:45	10	203	1	0	54	5	5	0	6	164	47	0	3	8	4	0	510
Total	24	743	15	0	218	25	15	0	34	767	147	0	17	24	22	0	2051
12:00	10	194	4	0	63	7	3	0	14	206	44	0	5	7	5	0	562
12:15	4	214	2	0	48	8	4	0	10	236	58	0	1	5	3	0	593
12:30	10	240	5	0	55	6	4	0	3	220	36	0	6	5	2	0	592
12:45	4	227	4	0	48	10	4	0	10	229	47	0	3	5	4	0	595
Total	28	875	15	0	214	31	15	0	37	891	185	0	15	22	14	0	2342
13:00	7	181	5	0	50	10	5	0	21	198	55	0	7	13	4	0	556
13:15	11	203	5	0	60	8	5	0	10	222	40	0	2	9	5	0	580
*** BREAK ***																	
Total	18	384	10	0	110	18	10	0	31	420	95	0	9	22	9	0	1136
*** BREAK ***																	
14:30	6	262	2	0	73	12	5	0	13	296	47	0	3	3	9	5	736
14:45	15	225	2	0	59	10	3	0	18	345	67	0	4	10	5	0	763
Total	21	487	4	0	132	22	8	0	31	641	114	0	7	13	14	5	1499
15:00	13	264	2	0	94	7	3	0	24	319	66	0	9	14	6	0	821
15:15	14	220	3	1	88	14	1	0	16	411	81	0	2	16	3	0	870
15:30	5	233	5	0	103	6	3	0	11	394	69	0	9	9	15	0	862
15:45	18	213	6	0	75	10	5	0	23	436	101	0	8	13	13	0	921
Total	50	930	16	1	360	37	12	0	74	1560	317	0	28	52	37	0	3474

# Alliant Engineering Inc

## Minneapolis, MN 55415

TH-65 at Medtronic Pkwy / Central Ave NE  
 Ref.Pt.: 006.636 FRIDLEY  
 data by Alliant Engineering Inc  
 TURN MOVEMENT COUNT

File Name : TH-65 at Medtronic Pkwy-Central Ave 2009  
 Site Code : 00000003  
 Start Date : 1/6/2009  
 Page No : 2

**Groups Printed- Unshifted**

Start Time	TH-65 / Central Ave Southbound				Central Ave NE Westbound				TH-65 / Central Ave Northbound				Medtronic Pkwy Eastbound				Int. Total
	Left	Thru	Right	Peds	Left	Thru	Right	Peds	Left	Thru	Right	Peds	Left	Thru	Right	Peds	
16:00	12	240	1	0	57	14	2	0	13	457	113	0	5	17	15	0	946
16:15	12	226	5	0	90	13	7	0	20	382	93	0	12	16	12	0	888
16:30	5	240	4	0	97	8	3	0	13	456	85	0	12	14	42	0	979
16:45	12	233	2	0	111	13	4	0	13	510	94	0	17	19	26	0	1054
Total	41	939	12	0	355	48	16	0	59	1805	385	0	46	66	95	0	3867
17:00	9	243	2	0	84	10	8	0	8	534	96	0	16	27	52	0	1089
17:15	14	234	2	0	102	5	3	0	26	477	103	0	14	18	35	0	1033
17:30	10	211	2	0	84	10	3	0	19	409	88	0	10	19	23	0	888
17:45	8	217	1	0	88	12	0	0	5	440	105	0	8	23	25	0	932
Total	41	905	7	0	358	37	14	0	58	1860	392	0	48	87	135	0	3942
Grand Total	462	10026	193	1	2884	403	156	1	783	10774	2627	0	220	376	341	5	29252
Apprch %	4.3	93.9	1.8	0	83.7	11.7	4.5	0	5.5	76	18.5	0	23.4	39.9	36.2	0.5	
Total %	1.6	34.3	0.7	0	9.9	1.4	0.5	0	2.7	36.8	9	0	0.8	1.3	1.2	0	

# Alliant Engineering Inc Minneapolis, MN 55415

TH-65 at Medtronic Pkwy / Central Ave NE  
 Ref.Pt.: 006.636 FRIDLEY  
 data by Alliant Engineering Inc  
 TURN MOVEMENT COUNT

File Name : TH-65 at Medtronic Pkwy-Central Ave 2009  
 Site Code : 00000003  
 Start Date : 1/6/2009  
 Page No : 3

Start Time	TH-65 / Central Ave Southbound					Central Ave NE Westbound					TH-65 / Central Ave Northbound					Medtronic Pkwy Eastbound					Int. Total
	Left	Thru	Right	Peds	App. Total	Left	Thru	Right	Peds	App. Total	Left	Thru	Right	Peds	App. Total	Left	Thru	Right	Peds	App. Total	
Peak Hour Analysis From 06:00 to 08:45 - Peak 1 of 1																					
Peak Hour for Entire Intersection Begins at 07:00																					
07:00	43	347	1	0	391	96	21	2	0	119	31	199	119	0	349	1	10	2	0	13	872
07:15	43	414	3	0	460	94	17	2	0	113	28	184	101	0	313	4	3	0	0	7	893
07:30	20	435	17	0	472	99	31	10	0	140	30	206	77	0	313	5	8	0	0	13	938
07:45	21	378	23	0	422	92	30	5	0	127	100	179	87	0	366	5	10	0	0	15	930
Total Volume	127	1574	44	0	1745	381	99	19	0	499	189	768	384	0	1341	15	31	2	0	48	3633
% App. Total	7.3	90.2	2.5	0		76.4	19.8	3.8	0		14.1	57.3	28.6	0		31.2	64.6	4.2	0		
PHF	.738	.905	.478	.000	.924	.962	.798	.475	.000	.891	.473	.932	.807	.000	.916	.750	.775	.250	.000	.800	.968

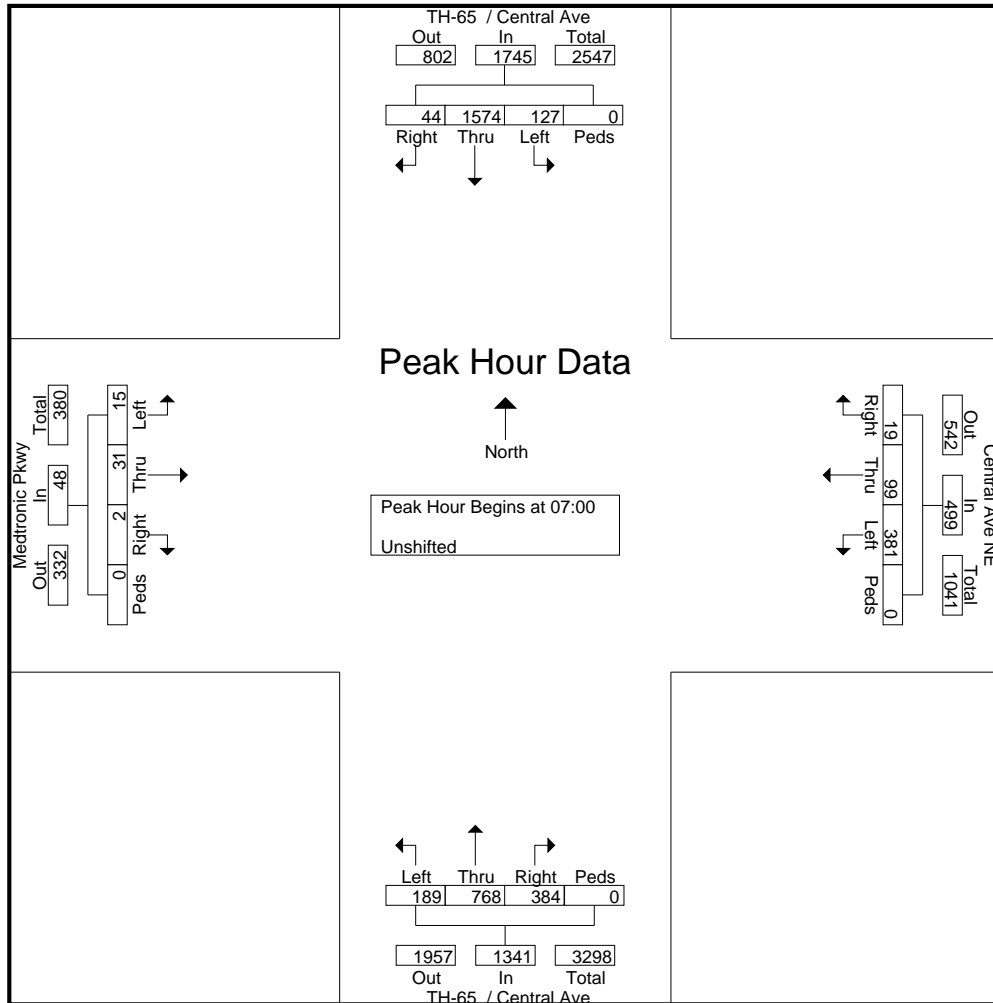

# Alliant Engineering Inc Minneapolis, MN 55415

TH-65 at Medtronic Pkwy / Central Ave NE  
 Ref.Pt.: 006.636 FRIDLEY  
 data by Alliant Engineering Inc  
 TURN MOVEMENT COUNT

File Name : TH-65 at Medtronic Pkwy-Central Ave 2009  
 Site Code : 00000003  
 Start Date : 1/6/2009  
 Page No : 4

Start Time	TH-65 / Central Ave Southbound					Central Ave NE Westbound					TH-65 / Central Ave Northbound					Medtronic Pkwy Eastbound					Int. Total
	Left	Thru	Right	Peds	App. Total	Left	Thru	Right	Peds	App. Total	Left	Thru	Right	Peds	App. Total	Left	Thru	Right	Peds	App. Total	
Peak Hour Analysis From 15:00 to 17:45 - Peak 1 of 1																					
Peak Hour for Entire Intersection Begins at 16:30																					
16:30	5	240	4	0	249	97	8	3	0	108	13	456	85	0	554	12	14	42	0	68	979
16:45	12	233	2	0	247	111	13	4	0	128	13	510	94	0	617	17	19	26	0	62	1054
17:00	9	243	2	0	254	84	10	8	0	102	8	534	96	0	638	16	27	52	0	95	1089
17:15	14	234	2	0	250	102	5	3	0	110	26	477	103	0	606	14	18	35	0	67	1033
Total Volume	40	950	10	0	1000	394	36	18	0	448	60	1977	378	0	2415	59	78	155	0	292	4155
% App. Total	4	95	1	0		87.9	8	4	0		2.5	81.9	15.7	0		20.2	26.7	53.1	0		
PHF	.714	.977	.625	.000	.984	.887	.692	.563	.000	.875	.577	.926	.917	.000	.946	.868	.722	.745	.000	.768	.954

