

Alliant Engineering Inc Minneapolis, MN 55415

TH-65 at 117th Ave NE / Cloud Dr NE
 Ref.Pt.: 014.451
 data collected by Alliant Engineering
 TURN MOVEMENT COUNT

File Name : TH-65 at 117th Ave NE 2009
 Site Code : 00000017
 Start Date : 1/22/2009
 Page No : 1

Groups Printed- Unshifted

| Start Time | TH-65 Southbound | | | | Cloud Dr NE Westbound | | | | TH-65 Northbound | | | | 117th Ave NE Eastbound | | | | Int. Total |
|---------------|------------------|------|-------|------|-----------------------|------|-------|------|------------------|------|-------|------|------------------------|------|-------|------|------------|
| | Left | Thru | Right | Peds | Left | Thru | Right | Peds | Left | Thru | Right | Peds | Left | Thru | Right | Peds | |
| 06:00 | 1 | 481 | 3 | 0 | 12 | 2 | 1 | 0 | 3 | 41 | 1 | 0 | 1 | 3 | 23 | 0 | 572 |
| 06:15 | 6 | 519 | 3 | 0 | 24 | 0 | 2 | 0 | 6 | 60 | 5 | 0 | 2 | 1 | 32 | 0 | 660 |
| 06:30 | 0 | 485 | 2 | 0 | 20 | 11 | 4 | 0 | 8 | 67 | 2 | 0 | 0 | 4 | 32 | 0 | 635 |
| 06:45 | 7 | 525 | 4 | 0 | 23 | 4 | 5 | 0 | 11 | 101 | 9 | 0 | 3 | 10 | 38 | 0 | 740 |
| Total | 14 | 2010 | 12 | 0 | 79 | 17 | 12 | 0 | 28 | 269 | 17 | 0 | 6 | 18 | 125 | 0 | 2607 |
| 07:00 | 3 | 502 | 18 | 0 | 22 | 16 | 8 | 0 | 6 | 99 | 5 | 0 | 4 | 8 | 38 | 0 | 729 |
| 07:15 | 8 | 425 | 13 | 0 | 16 | 11 | 7 | 0 | 17 | 106 | 10 | 0 | 5 | 4 | 34 | 0 | 656 |
| 07:30 | 5 | 454 | 22 | 0 | 15 | 10 | 6 | 0 | 15 | 123 | 13 | 0 | 4 | 7 | 23 | 0 | 697 |
| 07:45 | 14 | 455 | 14 | 0 | 22 | 10 | 6 | 0 | 12 | 96 | 10 | 0 | 7 | 11 | 33 | 0 | 690 |
| Total | 30 | 1836 | 67 | 0 | 75 | 47 | 27 | 0 | 50 | 424 | 38 | 0 | 20 | 30 | 128 | 0 | 2772 |
| 08:00 | 6 | 397 | 13 | 0 | 18 | 7 | 3 | 0 | 14 | 128 | 13 | 0 | 6 | 6 | 30 | 0 | 641 |
| 08:15 | 5 | 339 | 8 | 0 | 25 | 9 | 4 | 0 | 8 | 100 | 17 | 0 | 6 | 14 | 36 | 0 | 571 |
| 08:30 | 5 | 341 | 9 | 0 | 29 | 10 | 6 | 0 | 22 | 103 | 12 | 0 | 4 | 8 | 23 | 0 | 572 |
| 08:45 | 2 | 269 | 7 | 0 | 30 | 16 | 6 | 0 | 19 | 134 | 23 | 0 | 9 | 8 | 33 | 0 | 556 |
| Total | 18 | 1346 | 37 | 0 | 102 | 42 | 19 | 0 | 63 | 465 | 65 | 0 | 25 | 36 | 122 | 0 | 2340 |
| 09:00 | 5 | 266 | 12 | 0 | 28 | 16 | 3 | 0 | 24 | 115 | 15 | 0 | 6 | 10 | 24 | 0 | 524 |
| 09:15 | 6 | 244 | 5 | 0 | 23 | 11 | 3 | 0 | 22 | 111 | 14 | 0 | 12 | 12 | 31 | 0 | 494 |
| *** BREAK *** | | | | | | | | | | | | | | | | | |
| Total | 11 | 510 | 17 | 0 | 51 | 27 | 6 | 0 | 46 | 226 | 29 | 0 | 18 | 22 | 55 | 0 | 1018 |
| *** BREAK *** | | | | | | | | | | | | | | | | | |
| 10:30 | 8 | 214 | 8 | 0 | 23 | 9 | 4 | 0 | 15 | 117 | 16 | 0 | 2 | 13 | 33 | 0 | 462 |
| 10:45 | 7 | 215 | 14 | 0 | 13 | 13 | 3 | 0 | 27 | 155 | 20 | 0 | 7 | 12 | 19 | 0 | 505 |
| Total | 15 | 429 | 22 | 0 | 36 | 22 | 7 | 0 | 42 | 272 | 36 | 0 | 9 | 25 | 52 | 0 | 967 |
| 11:00 | 15 | 222 | 14 | 0 | 28 | 9 | 6 | 0 | 18 | 144 | 17 | 0 | 9 | 8 | 22 | 0 | 512 |
| 11:15 | 5 | 195 | 9 | 0 | 26 | 14 | 3 | 0 | 38 | 153 | 20 | 0 | 7 | 9 | 27 | 0 | 506 |
| 11:30 | 9 | 170 | 11 | 0 | 17 | 12 | 5 | 0 | 29 | 160 | 27 | 0 | 8 | 13 | 35 | 0 | 496 |
| 11:45 | 11 | 227 | 18 | 0 | 32 | 17 | 6 | 0 | 30 | 174 | 24 | 0 | 6 | 11 | 37 | 0 | 593 |
| Total | 40 | 814 | 52 | 0 | 103 | 52 | 20 | 0 | 115 | 631 | 88 | 0 | 30 | 41 | 121 | 0 | 2107 |
| 12:00 | 5 | 177 | 15 | 0 | 31 | 16 | 14 | 0 | 32 | 167 | 16 | 0 | 11 | 26 | 31 | 0 | 541 |
| 12:15 | 8 | 233 | 19 | 0 | 27 | 17 | 5 | 0 | 34 | 234 | 29 | 0 | 10 | 9 | 38 | 0 | 663 |
| 12:30 | 8 | 194 | 5 | 0 | 22 | 18 | 5 | 0 | 32 | 165 | 16 | 0 | 5 | 18 | 30 | 0 | 518 |
| 12:45 | 9 | 209 | 15 | 0 | 22 | 17 | 5 | 0 | 26 | 209 | 30 | 0 | 6 | 18 | 34 | 0 | 600 |
| Total | 30 | 813 | 54 | 0 | 102 | 68 | 29 | 0 | 124 | 775 | 91 | 0 | 32 | 71 | 133 | 0 | 2322 |
| 13:00 | 12 | 183 | 15 | 0 | 27 | 16 | 4 | 0 | 28 | 212 | 22 | 0 | 12 | 11 | 25 | 0 | 567 |
| 13:15 | 0 | 0 | 0 | 0 | 31 | 13 | 6 | 0 | 31 | 176 | 28 | 0 | 0 | 0 | 0 | 0 | 285 |
| *** BREAK *** | | | | | | | | | | | | | | | | | |
| Total | 12 | 183 | 15 | 0 | 58 | 29 | 10 | 0 | 59 | 388 | 50 | 0 | 12 | 11 | 25 | 0 | 852 |
| *** BREAK *** | | | | | | | | | | | | | | | | | |
| 14:30 | 9 | 198 | 7 | 0 | 14 | 14 | 5 | 0 | 31 | 315 | 26 | 0 | 7 | 11 | 30 | 0 | 667 |
| 14:45 | 12 | 207 | 7 | 0 | 24 | 15 | 5 | 0 | 34 | 391 | 38 | 0 | 11 | 9 | 23 | 0 | 776 |
| Total | 21 | 405 | 14 | 0 | 38 | 29 | 10 | 0 | 65 | 706 | 64 | 0 | 18 | 20 | 53 | 0 | 1443 |
| 15:00 | 8 | 169 | 10 | 0 | 16 | 25 | 7 | 0 | 33 | 377 | 39 | 0 | 10 | 12 | 27 | 0 | 733 |
| 15:15 | 11 | 214 | 17 | 0 | 19 | 21 | 5 | 0 | 40 | 397 | 26 | 0 | 18 | 14 | 32 | 0 | 814 |
| 15:30 | 6 | 197 | 12 | 0 | 28 | 20 | 6 | 0 | 53 | 393 | 39 | 0 | 16 | 23 | 25 | 1 | 819 |
| 15:45 | 12 | 200 | 12 | 1 | 24 | 18 | 5 | 0 | 46 | 415 | 60 | 0 | 16 | 24 | 25 | 0 | 858 |
| Total | 37 | 780 | 51 | 1 | 87 | 84 | 23 | 0 | 172 | 1582 | 164 | 0 | 60 | 73 | 109 | 1 | 3224 |

Alliant Engineering Inc

Minneapolis, MN 55415

TH-65 at 117th Ave NE / Cloud Dr NE
 Ref.Pt.: 014.451
 data collected by Alliant Engineering
 TURN MOVEMENT COUNT

File Name : TH-65 at 117th Ave NE 2009
 Site Code : 00000017
 Start Date : 1/22/2009
 Page No : 2

Groups Printed- Unshifted

| Start Time | TH-65 Southbound | | | | Cloud Dr NE Westbound | | | | TH-65 Northbound | | | | 117th Ave NE Eastbound | | | | Int. Total |
|-------------|------------------|-------|-------|------|-----------------------|------|-------|------|------------------|------|-------|------|------------------------|------|-------|------|------------|
| | Left | Thru | Right | Peds | Left | Thru | Right | Peds | Left | Thru | Right | Peds | Left | Thru | Right | Peds | |
| 16:00 | 13 | 231 | 6 | 0 | 20 | 21 | 12 | 0 | 55 | 440 | 43 | 0 | 20 | 31 | 47 | 0 | 939 |
| 16:15 | 13 | 185 | 13 | 0 | 27 | 22 | 14 | 0 | 42 | 457 | 37 | 0 | 18 | 19 | 38 | 0 | 885 |
| 16:30 | 9 | 231 | 15 | 0 | 32 | 20 | 5 | 0 | 47 | 469 | 26 | 0 | 21 | 24 | 41 | 0 | 940 |
| 16:45 | 7 | 223 | 19 | 0 | 30 | 31 | 9 | 0 | 48 | 486 | 25 | 0 | 18 | 27 | 40 | 0 | 963 |
| Total | 42 | 870 | 53 | 0 | 109 | 94 | 40 | 0 | 192 | 1852 | 131 | 0 | 77 | 101 | 166 | 0 | 3727 |
| 17:00 | 12 | 229 | 12 | 0 | 19 | 34 | 8 | 0 | 48 | 477 | 37 | 0 | 15 | 13 | 43 | 0 | 947 |
| 17:15 | 7 | 234 | 10 | 0 | 37 | 31 | 12 | 0 | 68 | 402 | 29 | 0 | 23 | 32 | 32 | 0 | 917 |
| 17:30 | 10 | 216 | 25 | 0 | 28 | 35 | 9 | 0 | 62 | 398 | 32 | 0 | 20 | 31 | 35 | 0 | 901 |
| 17:45 | 11 | 192 | 18 | 0 | 34 | 27 | 2 | 0 | 56 | 363 | 36 | 0 | 19 | 34 | 39 | 0 | 831 |
| Total | 40 | 871 | 65 | 0 | 118 | 127 | 31 | 0 | 234 | 1640 | 134 | 0 | 77 | 110 | 149 | 0 | 3596 |
| Grand Total | 310 | 10867 | 459 | 1 | 958 | 638 | 234 | 0 | 1190 | 9230 | 907 | 0 | 384 | 558 | 1238 | 1 | 26975 |
| Apprch % | 2.7 | 93.4 | 3.9 | 0 | 52.3 | 34.9 | 12.8 | 0 | 10.5 | 81.5 | 8 | 0 | 17.6 | 25.6 | 56.8 | 0 | |
| Total % | 1.1 | 40.3 | 1.7 | 0 | 3.6 | 2.4 | 0.9 | 0 | 4.4 | 34.2 | 3.4 | 0 | 1.4 | 2.1 | 4.6 | 0 | |

Alliant Engineering Inc Minneapolis, MN 55415

TH-65 at 117th Ave NE / Cloud Dr NE
 Ref.Pt.: 014.451
 data collected by Alliant Engineering
 TURN MOVEMENT COUNT

File Name : TH-65 at 117th Ave NE 2009
 Site Code : 00000017
 Start Date : 1/22/2009
 Page No : 3

| Start Time | TH-65 Southbound | | | | | Cloud Dr NE Westbound | | | | | TH-65 Northbound | | | | | 117th Ave NE Eastbound | | | | | Int. Total |
|--|------------------|------|-------|------|------------|-----------------------|------|-------|------|------------|------------------|------|-------|------|------------|------------------------|------|-------|------|------------|------------|
| | Left | Thru | Right | Peds | App. Total | Left | Thru | Right | Peds | App. Total | Left | Thru | Right | Peds | App. Total | Left | Thru | Right | Peds | App. Total | |
| Peak Hour Analysis From 06:00 to 09:00 - Peak 1 of 1 | | | | | | | | | | | | | | | | | | | | | |
| Peak Hour for Entire Intersection Begins at 06:45 | | | | | | | | | | | | | | | | | | | | | |
| 06:45 | 7 | 525 | 4 | 0 | 536 | 23 | 4 | 5 | 0 | 32 | 11 | 101 | 9 | 0 | 121 | 3 | 10 | 38 | 0 | 51 | 740 |
| 07:00 | 3 | 502 | 18 | 0 | 523 | 22 | 16 | 8 | 0 | 46 | 6 | 99 | 5 | 0 | 110 | 4 | 8 | 38 | 0 | 50 | 729 |
| 07:15 | 8 | 425 | 13 | 0 | 446 | 16 | 11 | 7 | 0 | 34 | 17 | 106 | 10 | 0 | 133 | 5 | 4 | 34 | 0 | 43 | 656 |
| 07:30 | 5 | 454 | 22 | 0 | 481 | 15 | 10 | 6 | 0 | 31 | 15 | 123 | 13 | 0 | 151 | 4 | 7 | 23 | 0 | 34 | 697 |
| Total Volume | 23 | 1906 | 57 | 0 | 1986 | 76 | 41 | 26 | 0 | 143 | 49 | 429 | 37 | 0 | 515 | 16 | 29 | 133 | 0 | 178 | 2822 |
| % App. Total | 1.2 | 96 | 2.9 | 0 | | 53.1 | 28.7 | 18.2 | 0 | | 9.5 | 83.3 | 7.2 | 0 | | 9 | 16.3 | 74.7 | 0 | | |
| PHF | .719 | .908 | .648 | .000 | .926 | .826 | .641 | .813 | .000 | .777 | .721 | .872 | .712 | .000 | .853 | .800 | .725 | .875 | .000 | .873 | .953 |

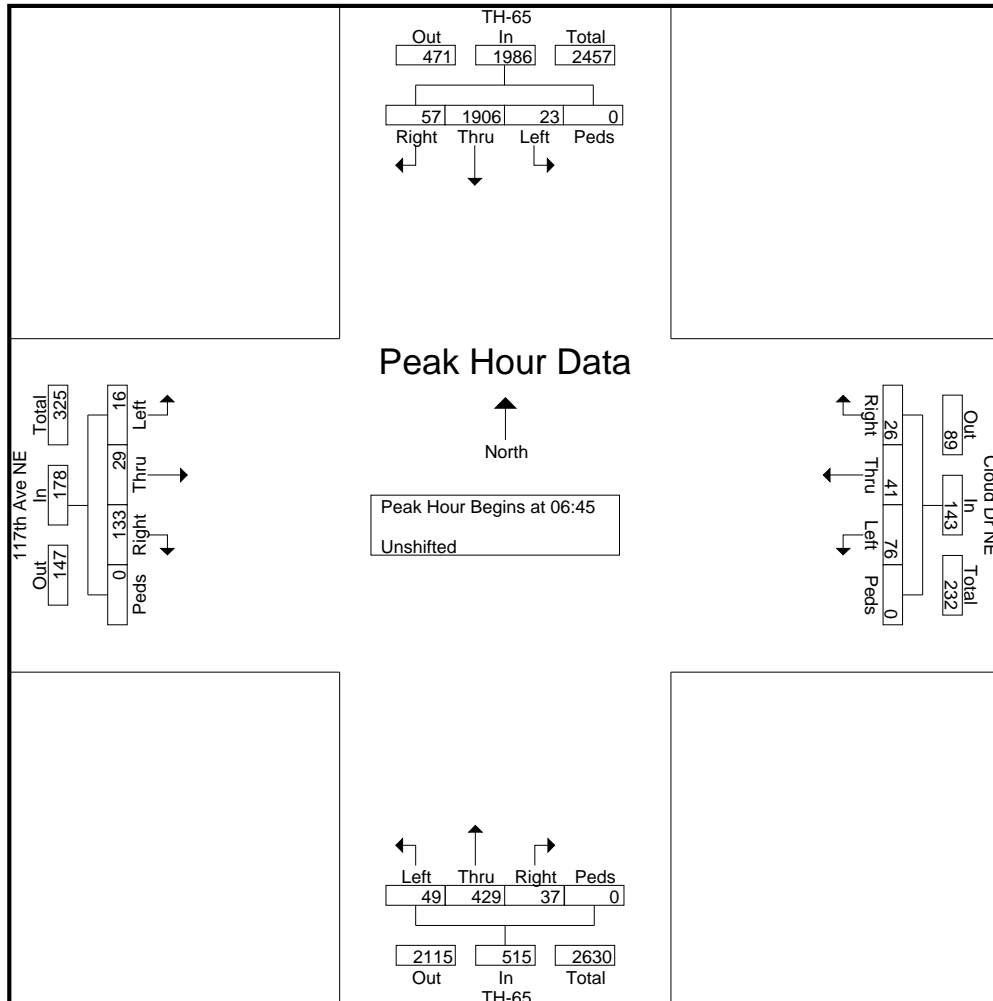

Alliant Engineering Inc Minneapolis, MN 55415

TH-65 at 117th Ave NE / Cloud Dr NE
 Ref.Pt.: 014.451
 data collected by Alliant Engineering
 TURN MOVEMENT COUNT

File Name : TH-65 at 117th Ave NE 2009
 Site Code : 00000017
 Start Date : 1/22/2009
 Page No : 4

| Start Time | TH-65 Southbound | | | | | Cloud Dr NE Westbound | | | | | TH-65 Northbound | | | | | 117th Ave NE Eastbound | | | | | Int. Total |
|--|------------------|------|-------|------|------------|-----------------------|------|-------|------|------------|------------------|------|-------|------|------------|------------------------|------|-------|------|------------|------------|
| | Left | Thru | Right | Peds | App. Total | Left | Thru | Right | Peds | App. Total | Left | Thru | Right | Peds | App. Total | Left | Thru | Right | Peds | App. Total | |
| Peak Hour Analysis From 15:00 to 17:45 - Peak 1 of 1 | | | | | | | | | | | | | | | | | | | | | |
| Peak Hour for Entire Intersection Begins at 16:30 | | | | | | | | | | | | | | | | | | | | | |
| 16:30 | 9 | 231 | 15 | 0 | 255 | 32 | 20 | 5 | 0 | 57 | 47 | 469 | 26 | 0 | 542 | 21 | 24 | 41 | 0 | 86 | 940 |
| 16:45 | 7 | 223 | 19 | 0 | 249 | 30 | 31 | 9 | 0 | 70 | 48 | 486 | 25 | 0 | 559 | 18 | 27 | 40 | 0 | 85 | 963 |
| 17:00 | 12 | 229 | 12 | 0 | 253 | 19 | 34 | 8 | 0 | 61 | 48 | 477 | 37 | 0 | 562 | 15 | 13 | 43 | 0 | 71 | 947 |
| 17:15 | 7 | 234 | 10 | 0 | 251 | 37 | 31 | 12 | 0 | 80 | 68 | 402 | 29 | 0 | 499 | 23 | 32 | 32 | 0 | 87 | 917 |
| Total Volume | 35 | 917 | 56 | 0 | 1008 | 118 | 116 | 34 | 0 | 268 | 211 | 1834 | 117 | 0 | 2162 | 77 | 96 | 156 | 0 | 329 | 3767 |
| % App. Total | 3.5 | 91 | 5.6 | 0 | | 44 | 43.3 | 12.7 | 0 | | 9.8 | 84.8 | 5.4 | 0 | | 23.4 | 29.2 | 47.4 | 0 | | |
| PHF | .729 | .980 | .737 | .000 | .988 | .797 | .853 | .708 | .000 | .838 | .776 | .943 | .791 | .000 | .962 | .837 | .750 | .907 | .000 | .945 | .978 |

