



# MINNESOTA DEPT OF TRANSPORTATION

## TRAFFIC DATA COLLECTION - METRO

TH-65 at Klondike Drive E BETHEL  
 Ref.Pt.: 024.911  
 JAMAR# 632 DR  
 TURN MOVEMENT COUNT

File Name : TH 65 at Klondike Dr 2010  
 Site Code : 00000000  
 Start Date : 3/10/2010  
 Page No : 1

Groups Printed- Unshifted

Start Time	TH-65 Southbound				KLONDIKE DRIVE Westbound				TH-65 Northbound				KLONDIKE DRIVE Eastbound				Int. Total
	Left	Thru	Right	Peds	Left	Thru	Right	Peds	Left	Thru	Right	Peds	Left	Thru	Right	Peds	
06:00	0	356	0	0	0	0	1	0	0	27	0	0	0	0	8	0	392
06:15	0	453	0	0	2	0	0	0	0	45	0	0	0	0	14	0	514
06:30	0	395	0	0	0	1	1	0	2	67	0	0	0	0	12	0	478
06:45	2	374	0	0	0	0	0	0	2	89	0	0	3	1	9	0	480
Total	2	1578	0	0	2	1	2	0	4	228	0	0	3	1	43	0	1864
07:00	0	405	1	0	0	0	0	0	0	84	1	0	1	0	13	0	505
07:15	0	360	1	0	2	0	3	0	2	84	0	0	1	1	12	0	466
07:30	0	342	1	0	1	0	1	0	6	139	1	0	2	0	12	0	505
07:45	0	278	0	0	0	2	0	0	15	106	1	0	1	2	26	0	431
Total	0	1385	3	0	3	2	4	0	23	413	3	0	5	3	63	0	1907
08:00	1	238	4	0	1	0	0	0	6	74	0	0	0	0	13	0	337
08:15	0	253	2	0	0	0	0	0	0	60	0	0	1	0	10	0	326
08:30	1	208	2	0	0	2	0	0	9	94	1	0	2	0	5	0	324
08:45	2	181	2	0	2	1	0	0	17	73	3	0	3	1	24	0	309
Total	4	880	10	0	3	3	0	0	32	301	4	0	6	1	52	0	1296
*** BREAK ***																	
15:00	1	123	2	0	0	2	1	0	15	259	0	0	1	0	7	0	411
15:15	3	135	1	0	3	0	3	0	23	288	1	0	1	1	8	0	467
15:30	5	120	0	0	0	0	2	0	14	317	2	0	6	3	19	0	488
15:45	3	140	1	0	2	0	0	0	13	347	1	0	8	2	13	0	530
Total	12	518	4	0	5	2	6	0	65	1211	4	0	16	6	47	0	1896
16:00	1	128	3	0	1	1	1	0	12	432	2	0	1	0	15	0	597
16:15	4	149	2	0	0	0	0	0	14	370	0	0	3	1	7	0	550
16:30	2	132	0	0	0	1	2	0	20	412	1	0	2	1	12	0	585
16:45	0	179	0	0	2	1	1	0	27	434	0	0	0	1	4	0	649
Total	7	588	5	0	3	3	4	0	73	1648	3	0	6	3	38	0	2381
17:00	7	189	3	0	2	0	0	0	14	404	0	0	6	0	9	0	634
17:15	2	149	0	0	2	0	1	0	19	376	1	0	1	1	4	0	556
17:30	0	136	1	0	3	0	3	0	20	381	0	0	0	0	3	0	547
17:45	1	149	2	0	0	5	2	0	22	321	2	0	4	0	7	0	515
Total	10	623	6	0	7	5	6	0	75	1482	3	0	11	1	23	0	2252
Grand Total	35	5572	28	0	23	16	22	0	272	5283	17	0	47	15	266	0	11596
Approch %	0.6	98.9	0.5	0	37.7	26.2	36.1	0	4.9	94.8	0.3	0	14.3	4.6	81.1	0	
Total %	0.3	48.1	0.2	0	0.2	0.1	0.2	0	2.3	45.6	0.1	0	0.4	0.1	2.3	0	



# MINNESOTA DEPT OF TRANSPORTATION

## TRAFFIC DATA COLLECTION - METRO

TH-65 at Klondike Drive E BETHEL  
 Ref.Pt.: 024.911  
 JAMAR# 632 DR  
 TURN MOVEMENT COUNT

File Name : TH 65 at Klondike Dr 2010  
 Site Code : 00000000  
 Start Date : 3/10/2010  
 Page No : 2

Start Time	TH-65 Southbound					KLONDIKE DRIVE Westbound					TH-65 Northbound					KLONDIKE DRIVE Eastbound					Int. Total
	Left	Thru	Right	Peds	App. Total	Left	Thru	Right	Peds	App. Total	Left	Thru	Right	Peds	App. Total	Left	Thru	Right	Peds	App. Total	
<b>Peak Hour Analysis From 06:00 to 08:45 - Peak 1 of 1</b>																					
Peak Hour for Entire Intersection Begins at 06:15																					
06:15	0	453	0	0	453	2	0	0	0	2	0	45	0	0	45	0	0	14	0	14	514
06:30	0	395	0	0	395	0	1	1	0	2	2	67	0	0	69	0	0	12	0	12	478
06:45	2	374	0	0	376	0	0	0	0	0	2	89	0	0	91	3	1	9	0	13	480
07:00	0	405	1	0	406	0	0	0	0	0	0	84	1	0	85	1	0	13	0	14	505
Total Volume	2	1627	1	0	1630	2	1	1	0	4	4	285	1	0	290	4	1	48	0	53	1977
% App. Total	0.1	99.8	0.1	0		50	25	25	0		1.4	98.3	0.3	0		7.5	1.9	90.6	0		
PHF	.250	.898	.250	.000	.900	.250	.250	.250	.000	.500	.500	.801	.250	.000	.797	.333	.250	.857	.000	.946	.962

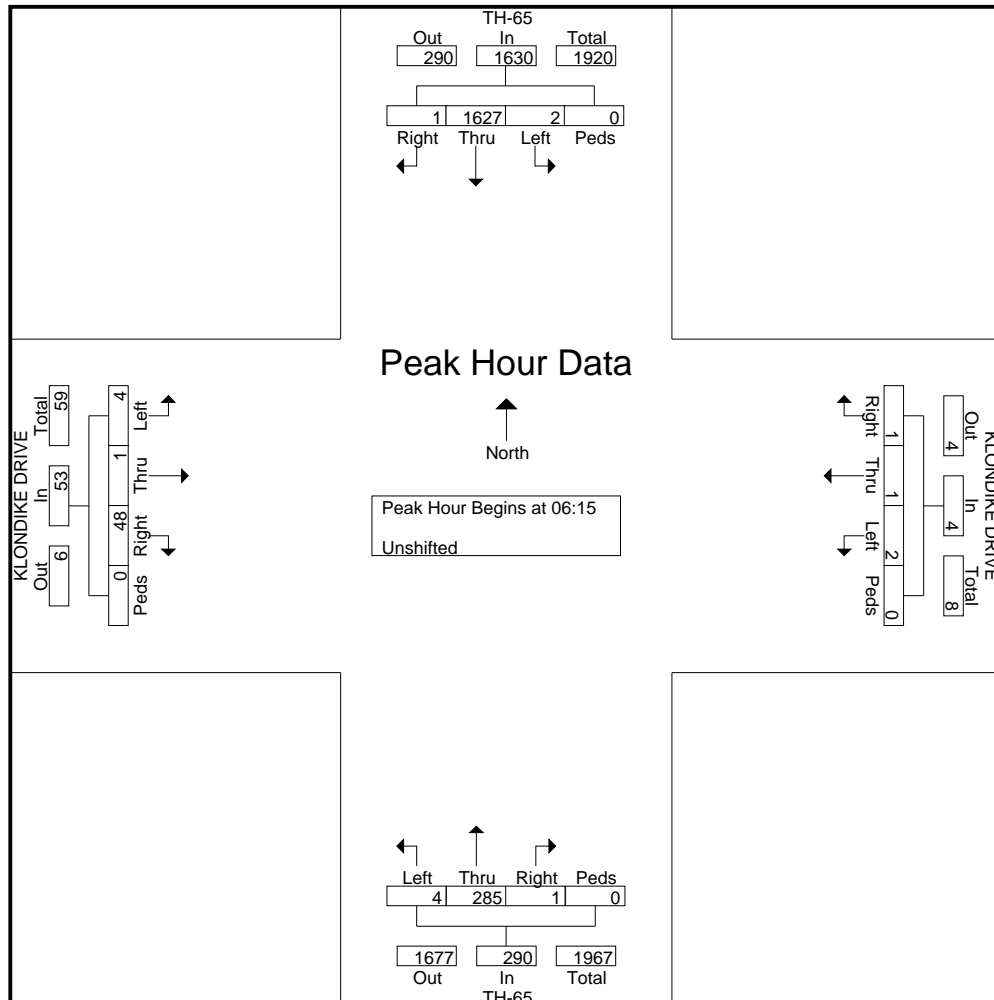



# MINNESOTA DEPT OF TRANSPORTATION

## TRAFFIC DATA COLLECTION - METRO

TH-65 at Klondike Drive E BETHEL  
 Ref.Pt.: 024.911  
 JAMAR# 632 DR  
 TURN MOVEMENT COUNT

File Name : TH 65 at Klondike Dr 2010  
 Site Code : 00000000  
 Start Date : 3/10/2010  
 Page No : 3

Start Time	TH-65 Southbound					KLONDIKE DRIVE Westbound					TH-65 Northbound					KLONDIKE DRIVE Eastbound					Int. Total
	Left	Thru	Right	Peds	App. Total	Left	Thru	Right	Peds	App. Total	Left	Thru	Right	Peds	App. Total	Left	Thru	Right	Peds	App. Total	
Peak Hour Analysis From 15:00 to 17:45 - Peak 1 of 1																					
Peak Hour for Entire Intersection Begins at 16:30																					
16:30	2	132	0	0	134	0	1	2	0	3	20	412	1	0	433	2	1	12	0	15	585
16:45	0	179	0	0	179	2	1	1	0	4	27	434	0	0	461	0	1	4	0	5	649
17:00	7	189	3	0	199	2	0	0	0	2	14	404	0	0	418	6	0	9	0	15	634
17:15	2	149	0	0	151	2	0	1	0	3	19	376	1	0	396	1	1	4	0	6	556
Total Volume	11	649	3	0	663	6	2	4	0	12	80	1626	2	0	1708	9	3	29	0	41	2424
% App. Total	1.7	97.9	0.5	0		50	16.7	33.3	0		4.7	95.2	0.1	0		22	7.3	70.7	0		
PHF	.393	.858	.250	.000	.833	.750	.500	.500	.000	.750	.741	.937	.500	.000	.926	.375	.750	.604	.000	.683	.934

