

SEH CONSULTING
Traffic Data Collection
TURN MOVEMENT COUNT

TH-95 at Myrtle Street E, STILLWATER
Ref.Pt.: 104.083
data by SEH
TURN MOVEMENT COUNT

File Name : TH-95 at Myrtle St 2008
Site Code : 00000013
Start Date : 12/10/2008
Page No : 1

Groups Printed- Unshifted - Heavy Veh

Start Time	TH-95 Southbound				Myrtle St Westbound				TH-95 Northbound				Myrtle St Eastbound				Int. Total
	Left	Thru	Right	Peds	Left	Thru	Right	Peds	Left	Thru	Right	Peds	Left	Thru	Right	Peds	
06:00	0	42	11	0	3	4	0	0	8	12	0	0	3	0	3	0	86
06:15	0	43	18	0	2	3	0	0	16	14	0	0	1	4	3	0	104
06:30	0	45	19	0	0	4	0	0	17	22	0	0	1	4	3	1	116
06:45	0	54	26	0	1	4	0	0	18	26	1	0	3	2	11	0	146
Total	0	184	74	0	6	15	0	0	59	74	1	0	8	10	20	1	452
07:00	0	66	25	0	1	1	2	0	22	17	2	0	6	3	11	0	156
07:15	1	66	32	0	0	5	1	0	21	28	4	0	7	1	6	0	172
07:30	0	68	29	0	6	9	1	0	24	35	4	2	10	6	10	3	207
07:45	0	72	35	0	6	5	1	1	32	28	3	0	11	5	10	0	209
Total	1	272	121	0	13	20	5	1	99	108	13	2	34	15	37	3	744
08:00	0	50	30	0	2	5	1	2	27	36	5	1	10	4	8	0	181
08:15	1	46	22	0	1	7	0	0	25	46	6	1	10	6	14	1	186
08:30	0	67	23	0	1	7	1	1	22	33	5	3	15	10	18	3	209
08:45	2	50	32	0	1	10	2	1	35	46	4	1	15	6	14	1	220
Total	3	213	107	0	5	29	4	4	109	161	20	6	50	26	54	5	796
*** BREAK ***																	
11:00	0	34	21	0	1	11	0	2	21	28	6	2	13	6	11	6	162
11:15	2	32	13	1	5	5	1	5	24	38	6	0	13	8	13	3	169
11:30	0	35	22	1	1	8	2	0	16	35	3	2	19	6	12	4	166
11:45	1	42	24	1	2	15	1	4	27	34	9	4	16	9	16	7	212
Total	3	143	80	3	9	39	4	11	88	135	24	8	61	29	52	20	709
12:00	1	30	20	1	3	7	0	4	15	35	3	2	15	5	19	4	164
12:15	1	35	19	3	3	7	4	3	18	31	5	3	20	14	15	10	191
12:30	2	49	15	5	4	7	3	0	35	29	2	5	10	5	22	5	198
12:45	0	48	18	1	10	14	3	4	14	39	6	4	15	7	20	3	206
Total	4	162	72	10	20	35	10	11	82	134	16	14	60	31	76	22	759
*** BREAK ***																	
15:00	0	38	8	2	0	12	1	2	17	54	3	0	22	6	31	1	197
15:15	0	57	9	3	3	13	1	3	23	63	4	1	23	7	33	2	245
15:30	0	61	9	2	2	8	0	6	23	59	3	1	33	8	21	3	239
15:45	0	41	17	2	5	10	2	2	22	52	4	0	43	11	14	5	230
Total	0	197	43	9	10	43	4	13	85	228	14	2	121	32	99	11	911
16:00	0	54	11	4	4	13	2	0	24	44	2	0	30	5	16	1	210
16:15	1	59	10	2	3	19	1	2	30	62	1	0	33	4	22	4	253
16:30	0	66	20	1	2	16	3	1	20	58	0	2	25	10	26	2	252
16:45	1	61	11	0	8	12	0	1	14	41	1	2	45	13	26	2	238
Total	2	240	52	7	17	60	6	4	88	205	4	4	133	32	90	9	953
17:00	0	67	6	1	1	2	1	0	25	65	1	0	10	4	34	0	217
17:15	1	64	15	2	0	10	2	2	20	43	1	0	34	8	34	2	238
17:30	1	49	15	0	4	10	3	1	17	52	3	0	29	8	24	3	219
17:45	1	50	9	1	2	4	0	1	23	50	2	5	42	2	36	3	231
Total	3	230	45	4	7	26	6	4	85	210	7	5	115	22	128	8	905
Grand Total	16	1641	594	33	87	267	39	48	695	1255	99	41	582	197	556	79	6229
Apprch %	0.7	71.8	26	1.4	19.7	60.5	8.8	10.9	33.3	60	4.7	2	41.2	13.9	39.3	5.6	
Total %	0.3	26.3	9.5	0.5	1.4	4.3	0.6	0.8	11.2	20.1	1.6	0.7	9.3	3.2	8.9	1.3	
Unshifted	16	1607	592	33	86	259	38	48	693	1236	99	41	574	196	556	79	6153
% Unshifted	100	97.9	99.7	100	98.9	97	97.4	100	99.7	98.5	100	100	98.6	99.5	100	100	98.8
Heavy Veh	0	34	2	0	1	8	1	0	2	19	0	0	8	1	0	0	76
% Heavy Veh	0	2.1	0.3	0	1.1	3	2.6	0	0.3	1.5	0	0	1.4	0.5	0	0	1.2

SEH CONSULTING
Traffic Data Collection
TURN MOVEMENT COUNT

TH-95 at Myrtle Street E, STILLWATER
Ref.Pt.: 104.083
data by SEH
TURN MOVEMENT COUNT

File Name : TH-95 at Myrtle St 2008
Site Code : 00000013
Start Date : 12/10/2008
Page No : 2

Start Time	TH-95 Southbound					Myrtle St Westbound					TH-95 Northbound					Myrtle St Eastbound					Int. Total
	Left	Thru	Right	Peds	App. Total	Left	Thru	Right	Peds	App. Total	Left	Thru	Right	Peds	App. Total	Left	Thru	Right	Peds	App. Total	
Peak Hour Analysis From 06:00 to 08:45 - Peak 1 of 1																					
Peak Hour for Entire Intersection Begins at 08:00																					
08:00	0	50	30	0	80	2	5	1	2	10	27	36	5	1	69	10	4	8	0	22	181
08:15	1	46	22	0	69	1	7	0	0	8	25	46	6	1	78	10	6	14	1	31	186
08:30	0	67	23	0	90	1	7	1	1	10	22	33	5	3	63	15	10	18	3	46	209
08:45	2	50	32	0	84	1	10	2	1	14	35	46	4	1	86	15	6	14	1	36	220
Total Volume	3	213	107	0	323	5	29	4	4	42	109	161	20	6	296	50	26	54	5	135	796
% App. Total	0.9	65.9	33.1	0		11.9	69	9.5	9.5		36.8	54.4	6.8	2		37	19.3	40	3.7		
PHF	.375	.795	.836	.000	.897	.625	.725	.500	.500	.750	.779	.875	.833	.500	.860	.833	.650	.750	.417	.734	.905

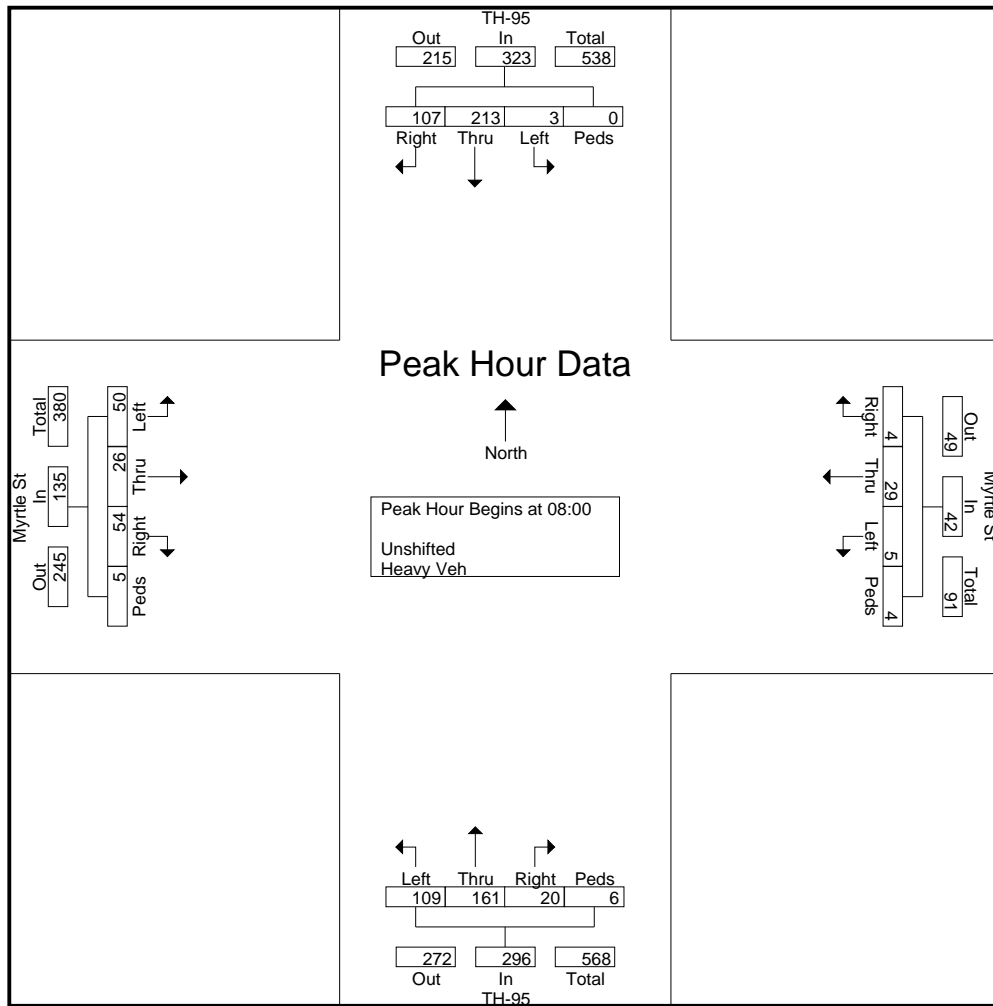

SEH CONSULTING
Traffic Data Collection
TURN MOVEMENT COUNT

TH-95 at Myrtle Street E, STILLWATER
Ref.Pt.: 104.083
data by SEH
TURN MOVEMENT COUNT

File Name : TH-95 at Myrtle St 2008
Site Code : 00000013
Start Date : 12/10/2008
Page No : 3

Start Time	TH-95 Southbound					Myrtle St Westbound					TH-95 Northbound					Myrtle St Eastbound					Int. Total
	Left	Thru	Right	Peds	App. Total	Left	Thru	Right	Peds	App. Total	Left	Thru	Right	Peds	App. Total	Left	Thru	Right	Peds	App. Total	
Peak Hour Analysis From 15:00 to 17:45 - Peak 1 of 1																					
Peak Hour for Entire Intersection Begins at 16:15																					
16:15	1	59	10	2	72	3	19	1	2	25	30	62	1	0	93	33	4	22	4	63	253
16:30	0	66	20	1	87	2	16	3	1	22	20	58	0	2	80	25	10	26	2	63	252
16:45	1	61	11	0	73	8	12	0	1	21	14	41	1	2	58	45	13	26	2	86	238
17:00	0	67	6	1	74	1	2	1	0	4	25	65	1	0	91	10	4	34	0	48	217
Total Volume	2	253	47	4	306	14	49	5	4	72	89	226	3	4	322	113	31	108	8	260	960
% App. Total	0.7	82.7	15.4	1.3		19.4	68.1	6.9	5.6		27.6	70.2	0.9	1.2		43.5	11.9	41.5	3.1		
PHF	.500	.944	.588	.500	.879	.438	.645	.417	.500	.720	.742	.869	.750	.500	.866	.628	.596	.794	.500	.756	.949

