

Alliant Engineering, Inc.

733 Marquette Ave #700, Minneapolis, MN 55402

Prairie Center Dr & Singletree Ln

File Name : 21_EP_Prairie Center Dr at Singletree Ln

Ref Pt:

Site Code :

data by: Alliant Inc

Start Date : 12/17/2020

TURN MOVEMENT COUNT

Page No : 1

Groups Printed- Cars - Trucks

Start Time	Prairie Center Dr Southbound					Singletree Ln Westbound					Prairie Center Dr Northbound					Singletree Ln Eastbound					Int. Total
	Right	Thru	Left	Peds	App. Total	Right	Thru	Left	Peds	App. Total	Right	Thru	Left	Peds	App. Total	Right	Thru	Left	Peds	App. Total	
06:00 AM	0	15	1	0	16	2	0	0	0	2	0	14	0	0	14	0	0	0	0	0	32
06:15 AM	0	35	11	0	46	5	0	0	0	5	1	10	0	0	11	0	0	0	0	0	62
06:30 AM	0	39	12	0	51	6	0	0	0	6	0	27	1	0	28	0	0	0	0	0	85
06:45 AM	0	45	25	3	73	12	0	1	0	13	0	30	0	0	30	0	0	0	0	0	116
Total	0	134	49	3	186	25	0	1	0	26	1	81	1	0	83	0	0	0	0	0	295
07:00 AM	1	19	12	2	34	15	0	0	0	15	0	28	2	0	30	0	0	1	0	1	80
07:15 AM	0	31	27	0	58	14	0	0	0	14	1	41	2	1	45	0	0	0	0	0	117
07:30 AM	0	50	27	0	77	15	1	1	0	17	2	55	1	0	58	0	0	1	0	1	153
07:45 AM	1	67	32	0	100	13	1	1	0	15	1	57	4	0	62	0	1	4	0	5	182
Total	2	167	98	2	269	57	2	2	0	61	4	181	9	1	195	0	1	6	0	7	532
08:00 AM	2	56	32	0	90	8	2	2	0	12	2	42	5	0	49	0	0	2	1	3	154
08:15 AM	2	54	33	0	89	21	1	1	0	23	2	59	6	0	67	2	0	0	0	2	181
08:30 AM	1	61	34	0	96	15	0	2	0	17	3	40	2	0	45	2	0	0	0	2	160
08:45 AM	3	81	42	1	127	26	3	5	0	34	5	56	2	0	63	0	0	1	1	2	226
Total	8	252	141	1	402	70	6	10	0	86	12	197	15	0	224	4	0	3	2	9	721
09:00 AM	0	74	47	1	122	24	1	8	0	33	2	65	0	0	67	0	0	0	0	0	222
09:15 AM	1	89	48	0	138	35	1	7	0	43	2	63	2	0	67	3	0	0	0	3	251
*** BREAK ***																					
Total	1	163	95	1	260	59	2	15	0	76	4	128	2	0	134	3	0	0	0	3	473
*** BREAK ***																					
10:30 AM	2	119	63	1	185	45	2	4	0	51	8	105	0	0	113	0	0	4	0	4	353
10:45 AM	2	126	91	1	220	40	0	8	0	48	10	114	3	0	127	0	1	1	0	2	397
Total	4	245	154	2	405	85	2	12	0	99	18	219	3	0	240	0	1	5	0	6	750
11:00 AM	1	144	82	0	227	44	2	4	0	50	11	112	1	0	124	0	0	1	0	1	402
11:15 AM	1	146	81	1	229	67	1	5	0	73	9	152	1	0	162	1	0	1	0	2	466
11:30 AM	1	170	77	0	248	63	0	8	0	71	12	136	1	0	149	0	2	4	0	6	474
11:45 AM	2	171	97	0	270	67	3	8	0	78	16	182	3	0	201	1	0	2	0	3	552
Total	5	631	337	1	974	241	6	25	0	272	48	582	6	0	636	2	2	8	0	12	1894
12:00 PM	0	159	106	0	265	58	1	19	0	78	20	172	0	0	192	1	1	0	0	2	537
12:15 PM	1	145	93	1	240	77	0	15	0	92	8	171	2	0	181	1	0	6	0	7	520
12:30 PM	3	152	105	0	260	73	1	12	0	86	10	179	1	0	190	2	0	3	0	5	541
12:45 PM	2	195	70	1	268	84	2	6	0	92	10	159	2	0	171	0	2	3	1	6	537
Total	6	651	374	2	1033	292	4	52	0	348	48	681	5	0	734	4	3	12	1	20	2135
01:00 PM	1	163	93	0	257	60	0	12	2	74	15	185	0	0	200	2	0	2	0	4	535
01:15 PM	3	175	107	0	285	91	0	8	0	99	10	166	3	0	179	1	2	1	0	4	567
*** BREAK ***																					
Total	4	338	200	0	542	151	0	20	2	173	25	351	3	0	379	3	2	3	0	8	1102
*** BREAK ***																					
02:30 PM	1	158	98	0	257	71	3	7	0	81	7	175	2	0	184	0	1	2	0	3	525
02:45 PM	3	170	97	2	272	86	1	12	0	99	15	170	2	0	187	0	0	1	1	2	560
Total	4	328	195	2	529	157	4	19	0	180	22	345	4	0	371	0	1	3	1	5	1085
03:00 PM	0	175	88	0	263	71	1	11	0	83	6	160	1	0	167	1	2	2	0	5	518
03:15 PM	0	162	118	1	281	71	1	7	0	79	16	174	1	0	191	0	1	1	0	2	553
03:30 PM	0	168	109	1	278	84	2	18	1	105	13	165	1	0	179	0	1	2	0	3	565
03:45 PM	1	194	111	2	308	93	0	16	0	109	5	181	0	0	186	3	1	3	1	8	611
Total	1	699	426	4	1130	319	4	52	1	376	40	680	3	0	723	4	5	8	1	18	2247
04:00 PM	2	171	87	1	261	80	0	14	0	94	11	184	1	0	196	5	2	3	0	10	561

Alliant Engineering, Inc.

733 Marquette Ave #700, Minneapolis, MN 55402

Prairie Center Dr & Singletree Ln

File Name : 21_EP_Prairie Center Dr at Singletree Ln

Ref Pt:

Site Code :

data by: Alliant Inc

Start Date : 12/17/2020

TURN MOVEMENT COUNT

Page No : 2

Groups Printed- Cars - Trucks

Start Time	Prairie Center Dr Southbound					Singletree Ln Westbound					Prairie Center Dr Northbound					Singletree Ln Eastbound					Int. Total
	Right	Thru	Left	Peds	App. Total	Right	Thru	Left	Peds	App. Total	Right	Thru	Left	Peds	App. Total	Right	Thru	Left	Peds	App. Total	
04:15 PM	0	209	96	1	306	73	1	13	0	87	18	215	2	0	235	4	0	4	1	9	637
04:30 PM	2	186	99	0	287	94	0	11	0	105	20	178	0	0	198	3	0	3	0	6	596
04:45 PM	3	168	102	0	273	85	0	16	0	101	14	199	2	0	215	4	0	5	0	9	598
Total	7	734	384	2	1127	332	1	54	0	387	63	776	5	0	844	16	2	15	1	34	2392
05:00 PM	1	152	98	0	251	93	0	13	0	106	15	189	0	0	204	3	2	1	0	6	567
05:15 PM	0	177	107	0	284	98	1	19	0	118	18	211	2	0	231	2	0	3	0	5	638
05:30 PM	1	152	92	1	246	77	0	11	0	88	13	175	0	0	188	0	1	5	0	6	528
05:45 PM	0	162	89	0	251	96	0	6	0	102	11	161	1	0	173	2	2	0	0	4	530
Total	2	643	386	1	1032	364	1	49	0	414	57	736	3	0	796	7	5	9	0	21	2263
Grand Total	44	4985	2839	21	7889	2152	32	311	3	2498	342	4957	59	1	5359	43	22	72	6	143	15889
Apprch %	0.6	63.2	36	0.3		86.1	1.3	12.4	0.1		6.4	92.5	1.1	0		30.1	15.4	50.3	4.2		
Total %	0.3	31.4	17.9	0.1	49.7	13.5	0.2	2	0	15.7	2.2	31.2	0.4	0	33.7	0.3	0.1	0.5	0	0.9	
Cars	42	4923	2821	21	7807	2120	32	305	3	2460	340	4898	59	1	5298	42	21	72	6	141	15706
% Cars	95.5	98.8	99.4	100	99	98.5	100	98.1	100	98.5	99.4	98.8	100	100	98.9	97.7	95.5	100	100	98.6	98.8
Trucks	2	62	18	0	82	32	0	6	0	38	2	59	0	0	61	1	1	0	0	2	183
% Trucks	4.5	1.2	0.6	0	1	1.5	0	1.9	0	1.5	0.6	1.2	0	0	1.1	2.3	4.5	0	0	1.4	1.2

Alliant Engineering, Inc.

733 Marquette Ave #700, Minneapolis, MN 55402

Prairie Center Dr & Singletree Ln
 Ref Pt:
 data by: Alliant Inc
 TURN MOVEMENT COUNT

File Name : 21_EP_Prairie Center Dr at Singletree Ln
 Site Code :
 Start Date : 12/17/2020
 Page No : 3

Start Time	Prairie Center Dr Southbound					Singletree Ln Westbound					Prairie Center Dr Northbound					Singletree Ln Eastbound					Int. Total
	Right	Thru	Left	Peds	App. Total	Right	Thru	Left	Peds	App. Total	Right	Thru	Left	Peds	App. Total	Right	Thru	Left	Peds	App. Total	
Peak Hour Analysis From 06:00 AM to 09:45 AM - Peak 1 of 1																					
Peak Hour for Entire Intersection Begins at 08:30 AM																					
08:30 AM	1	61	34	0	96	15	0	2	0	17	3	40	2	0	45	2	0	0	0	2	160
08:45 AM	3	81	42	1	127	26	3	5	0	34	5	56	2	0	63	0	0	1	1	2	226
09:00 AM	0	74	47	1	122	24	1	8	0	33	2	65	0	0	67	0	0	0	0	0	222
09:15 AM	1	89	48	0	138	35	1	7	0	43	2	63	2	0	67	3	0	0	0	3	251
Total Volume	5	305	171	2	483	100	5	22	0	127	12	224	6	0	242	5	0	1	1	7	859
% App. Total	1	63.1	35.4	0.4		78.7	3.9	17.3	0		5	92.6	2.5	0		71.4	0	14.3	14.3		
PHF	.417	.857	.891	.500	.875	.714	.417	.688	.000	.738	.600	.862	.750	.000	.903	.417	.000	.250	.250	.583	.856

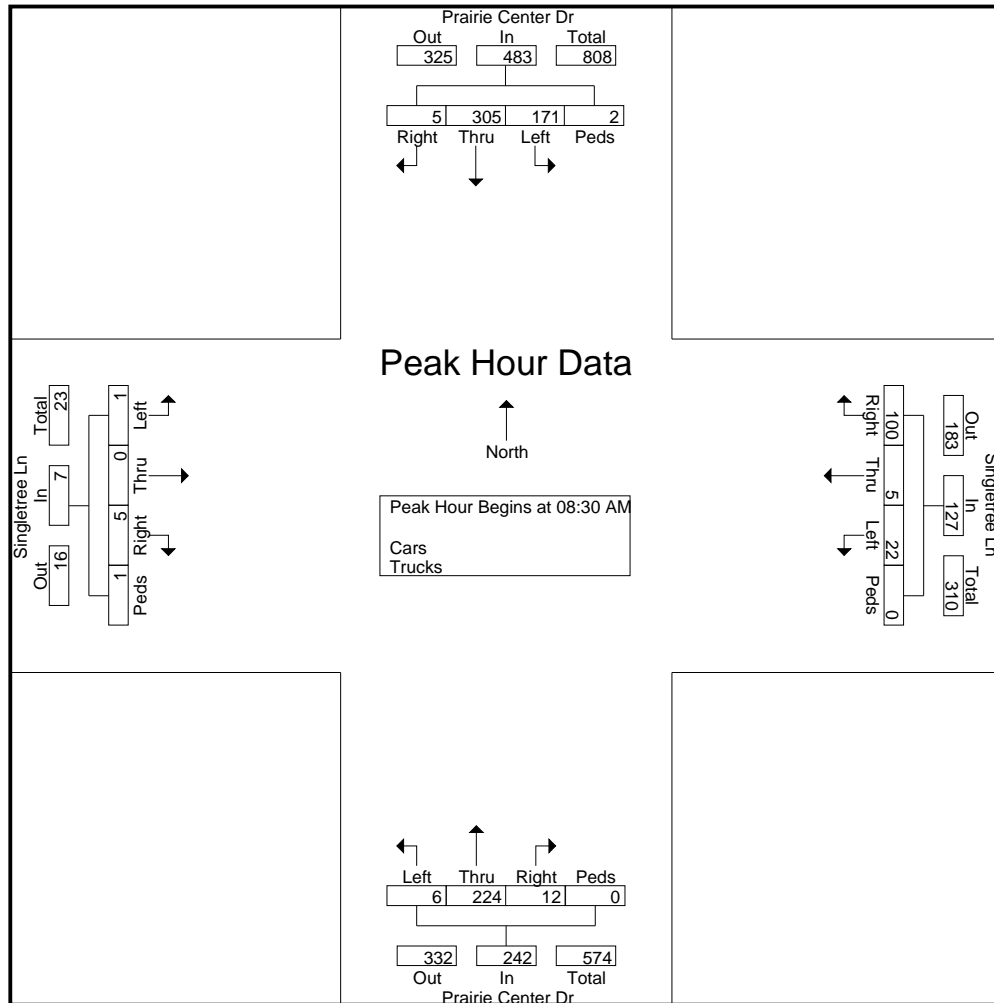

Alliant Engineering, Inc.

733 Marquette Ave #700, Minneapolis, MN 55402

Prairie Center Dr & Singletree Ln
 Ref Pt:
 data by: Alliant Inc
 TURN MOVEMENT COUNT

File Name : 21_EP_Prairie Center Dr at Singletree Ln
 Site Code :
 Start Date : 12/17/2020
 Page No : 4

Start Time	Prairie Center Dr Southbound					Singletree Ln Westbound					Prairie Center Dr Northbound					Singletree Ln Eastbound					Int. Total
	Right	Thru	Left	Peds	App. Total	Right	Thru	Left	Peds	App. Total	Right	Thru	Left	Peds	App. Total	Right	Thru	Left	Peds	App. Total	
Peak Hour Analysis From 10:00 AM to 01:45 PM - Peak 1 of 1																					
Peak Hour for Entire Intersection Begins at 12:30 PM																					
12:30 PM	3	152	105	0	260	73	1	12	0	86	10	179	1	0	190	2	0	3	0	5	541
12:45 PM	2	195	70	1	268	84	2	6	0	92	10	159	2	0	171	0	2	3	1	6	537
01:00 PM	1	163	93	0	257	60	0	12	2	74	15	185	0	0	200	2	0	2	0	4	535
01:15 PM	3	175	107	0	285	91	0	8	0	99	10	166	3	0	179	1	2	1	0	4	567
Total Volume	9	685	375	1	1070	308	3	38	2	351	45	689	6	0	740	5	4	9	1	19	2180
% App. Total	0.8	64	35	0.1		87.7	0.9	10.8	0.6		6.1	93.1	0.8	0		26.3	21.1	47.4	5.3		
PHF	.750	.878	.876	.250	.939	.846	.375	.792	.250	.886	.750	.931	.500	.000	.925	.625	.500	.750	.250	.792	.961

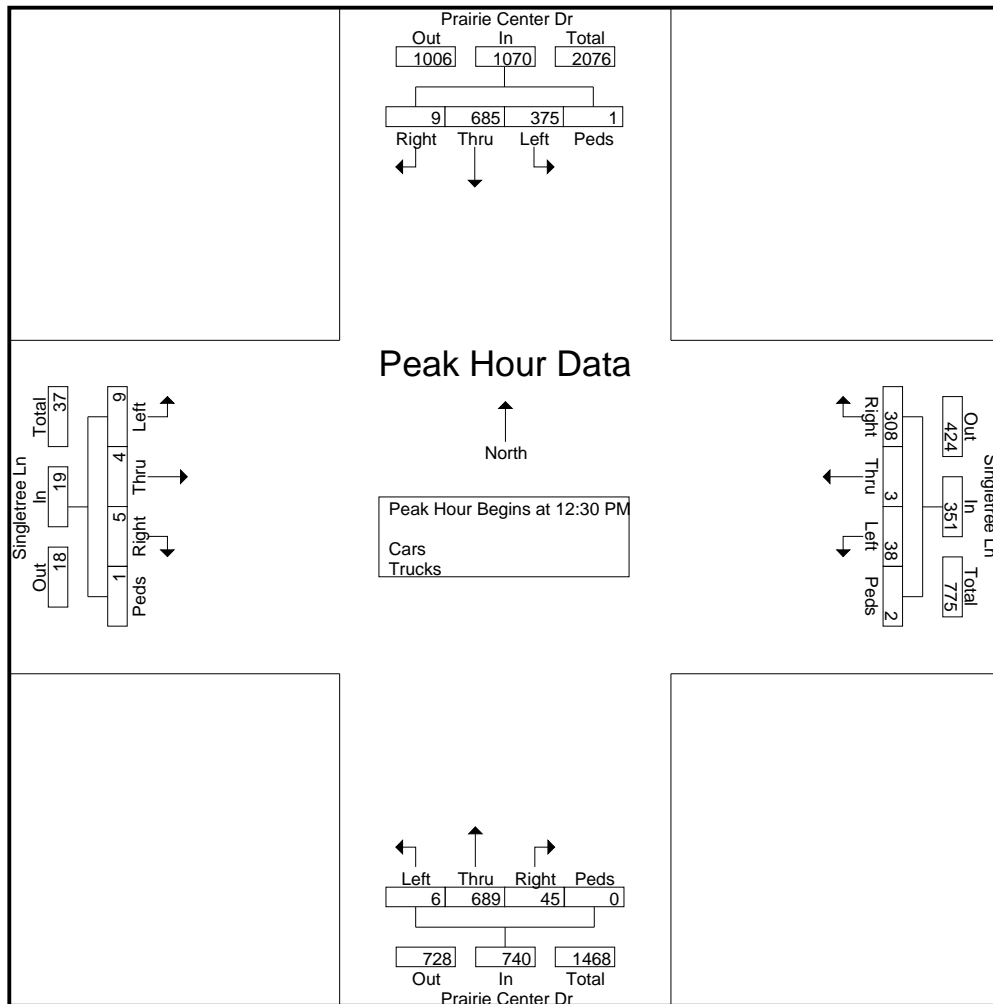

Alliant Engineering, Inc.

733 Marquette Ave #700, Minneapolis, MN 55402

Prairie Center Dr & Singletree Ln
 Ref Pt:
 data by: Alliant Inc
 TURN MOVEMENT COUNT

File Name : 21_EP_Prairie Center Dr at Singletree Ln
 Site Code :
 Start Date : 12/17/2020
 Page No : 5

Start Time	Prairie Center Dr Southbound					Singletree Ln Westbound					Prairie Center Dr Northbound					Singletree Ln Eastbound					Int. Total
	Right	Thru	Left	Peds	App. Total	Right	Thru	Left	Peds	App. Total	Right	Thru	Left	Peds	App. Total	Right	Thru	Left	Peds	App. Total	
Peak Hour Analysis From 02:00 PM to 05:45 PM - Peak 1 of 1																					
Peak Hour for Entire Intersection Begins at 03:45 PM																					
03:45 PM	1	194	111	2	308	93	0	16	0	109	5	181	0	0	186	3	1	3	1	8	611
04:00 PM	2	171	87	1	261	80	0	14	0	94	11	184	1	0	196	5	2	3	0	10	561
04:15 PM	0	209	96	1	306	73	1	13	0	87	18	215	2	0	235	4	0	4	1	9	637
04:30 PM	2	186	99	0	287	94	0	11	0	105	20	178	0	0	198	3	0	3	0	6	596
Total Volume	5	760	393	4	1162	340	1	54	0	395	54	758	3	0	815	15	3	13	2	33	2405
% App. Total	0.4	65.4	33.8	0.3		86.1	0.3	13.7	0		6.6	93	0.4	0		45.5	9.1	39.4	6.1		
PHF	.625	.909	.885	.500	.943	.904	.250	.844	.000	.906	.675	.881	.375	.000	.867	.750	.375	.813	.500	.825	.944

