

# Short Elliott Hendrickson Inc.

3535 Vadnais Center Drive  
St. Paul, MN 55110

"Building a Better World for All of Us"



## TRAFFIC DATA

TH 52 & Thompson Ave E Ramp

Ref.Pt.: 127.633

Data By: Short Elliott Hendrickson, Inc.

TURN MOVEMENT COUNT

File Name : TH 52 & Thompson Ave E Ramp 2019

Site Code : 5b

Start Date : 5/2/2019

Page No : 1

### Groups Printed- Vehicles - Trucks

Start Time	Southbound					Westbound					Northbound					Eastbound					Int. Total
	Left	Thru	Right	Peds	App. Total	Left	Thru	Right	Peds	App. Total	Left	Thru	Right	Peds	App. Total	Left	Thru	Right	Peds	App. Total	
06:00	0	0	0	0	0	0	17	28	0	45	5	21	6	0	32	27	7	0	0	34	111
06:15	0	0	0	0	0	0	19	30	0	49	12	23	3	0	38	33	12	0	0	45	132
06:30	0	0	0	0	0	0	22	39	0	61	9	29	4	0	42	22	12	0	0	34	137
06:45	0	0	0	1	1	0	42	27	0	69	28	26	5	0	59	29	20	0	0	49	178
Total	0	0	0	1	1	0	100	124	0	224	54	99	18	0	171	111	51	0	0	162	558
07:00	0	0	0	0	0	0	49	40	0	89	24	28	10	0	62	28	26	0	0	54	205
07:15	0	0	0	0	0	0	70	42	0	112	25	34	17	0	76	17	29	0	0	46	234
07:30	0	0	0	0	0	0	68	35	0	103	31	32	8	2	73	25	40	0	0	65	241
07:45	0	0	0	0	0	0	62	28	0	90	29	24	9	0	62	28	30	0	0	58	210
Total	0	0	0	0	0	0	249	145	0	394	109	118	44	2	273	98	125	0	0	223	890
08:00	0	0	0	1	1	0	41	30	0	71	15	22	9	0	46	29	32	0	0	61	179
08:15	0	0	0	0	0	0	51	29	0	80	20	33	6	0	59	21	28	0	0	49	188
08:30	0	0	0	0	0	0	42	28	0	70	19	22	9	0	50	27	20	0	0	47	167
08:45	0	0	0	1	1	0	39	19	0	58	15	24	8	0	47	17	26	0	0	43	149
Total	0	0	0	2	2	0	173	106	0	279	69	101	32	0	202	94	106	0	0	200	683
09:00	0	0	0	0	0	0	32	19	0	51	19	32	6	0	57	25	13	0	0	38	146
09:15	0	0	0	0	0	0	29	9	0	38	15	17	7	0	39	29	24	0	0	53	130
09:30	0	0	0	0	0	0	38	11	0	49	13	30	11	0	54	25	21	0	0	46	149
09:45	0	0	0	0	0	0	34	10	0	44	19	25	7	0	51	29	34	0	0	63	158
Total	0	0	0	0	0	0	133	49	0	182	66	104	31	0	201	108	92	0	0	200	583
10:00	0	0	0	0	0	0	35	14	0	49	17	30	8	0	55	31	28	0	0	59	163
10:15	0	0	0	0	0	0	34	8	0	42	17	30	6	0	53	28	37	0	0	65	160
10:30	0	0	0	0	0	0	34	10	1	45	12	27	8	0	47	30	22	0	0	52	144
10:45	0	0	0	1	1	0	37	10	0	47	21	27	7	1	56	28	24	0	1	53	157
Total	0	0	0	1	1	0	140	42	1	183	67	114	29	1	211	117	111	0	1	229	624
11:00	0	0	0	0	0	0	38	8	0	46	11	28	6	0	45	31	27	0	0	58	149
11:15	0	0	0	0	0	0	30	14	0	44	13	39	16	0	68	36	32	0	0	68	180
11:30	0	0	0	0	0	0	25	16	0	41	11	36	9	0	56	37	38	0	0	75	172
11:45	0	0	0	0	0	0	23	17	0	40	10	42	11	0	63	34	35	0	0	69	172
Total	0	0	0	0	0	0	116	55	0	171	45	145	42	0	232	138	132	0	0	270	673
12:00	0	0	0	0	0	0	43	13	0	56	13	59	16	0	88	41	31	0	0	72	216
12:15	0	0	0	0	0	0	37	15	0	52	23	46	7	0	76	43	31	0	0	74	202
12:30	0	0	0	1	1	0	38	13	0	51	13	46	10	0	69	47	39	0	0	86	207
12:45	0	0	0	0	0	0	27	12	0	39	18	57	9	0	84	44	36	0	0	80	203
Total	0	0	0	1	1	0	145	53	0	198	67	208	42	0	317	175	137	0	0	312	828
13:00	0	0	0	0	0	0	38	16	0	54	17	54	13	0	84	42	39	0	0	81	219
13:15	0	0	0	0	0	0	32	13	0	45	19	31	10	0	60	42	35	0	0	77	182
13:30	0	0	0	0	0	0	33	11	0	44	18	49	9	0	76	50	28	0	0	78	198
13:45	0	0	0	0	0	0	38	14	0	52	26	28	13	0	67	26	41	0	0	67	186
Total	0	0	0	0	0	0	141	54	0	195	80	162	45	0	287	160	143	0	0	303	785

# Short Elliott Hendrickson Inc.

3535 Vadnais Center Drive  
St. Paul, MN 55110

"Building a Better World for All of Us"



## TRAFFIC DATA

TH 52 & Thompson Ave E Ramp

Ref.Pt.: 127.633

Data By: Short Elliott Hendrickson, Inc.

TURN MOVEMENT COUNT

File Name : TH 52 & Thompson Ave E Ramp 2019

Site Code : 5b

Start Date : 5/2/2019

Page No : 2

Groups Printed- Vehicles - Trucks

Start Time	Southbound					Westbound					Northbound					Eastbound					Int. Total
	Left	Thru	Right	Peds	App. Total	Left	Thru	Right	Peds	App. Total	Left	Thru	Right	Peds	App. Total	Left	Thru	Right	Peds	App. Total	
14:00	0	0	0	0	0	0	32	9	0	41	9	49	16	0	74	61	40	0	0	101	216
14:15	0	0	0	1	1	0	36	7	1	44	17	34	10	1	62	59	53	0	0	112	219
14:30	0	0	0	0	0	0	35	22	1	58	20	54	13	0	87	67	42	0	0	109	254
14:45	0	0	0	1	1	0	35	25	0	60	17	43	23	0	83	37	54	0	0	91	235
Total	0	0	0	2	2	0	138	63	2	203	63	180	62	1	306	224	189	0	0	413	924
15:00	0	0	0	0	0	0	49	29	0	78	14	58	16	0	88	35	54	0	0	89	255
15:15	0	0	0	0	0	0	38	20	0	58	18	47	11	1	77	39	49	0	0	88	223
15:30	0	0	0	0	0	0	51	15	0	66	19	48	19	0	86	40	70	0	0	110	262
15:45	0	0	0	1	1	0	46	13	1	60	17	49	28	0	94	41	49	0	0	90	245
Total	0	0	0	1	1	0	184	77	1	262	68	202	74	1	345	155	222	0	0	377	985
16:00	0	0	0	0	0	0	40	15	0	55	23	42	17	0	82	30	77	0	0	107	244
16:15	0	0	0	0	0	0	45	11	0	56	18	37	21	0	76	35	86	0	0	121	253
16:30	0	0	0	0	0	0	48	15	0	63	13	51	25	0	89	53	63	0	0	116	268
16:45	0	0	0	2	2	0	52	20	0	72	16	43	23	0	82	41	61	0	0	102	258
Total	0	0	0	2	2	0	185	61	0	246	70	173	86	0	329	159	287	0	0	446	1023
17:00	0	0	0	0	0	0	48	12	0	60	16	39	23	0	78	39	72	0	0	111	249
17:15	0	0	0	2	2	0	45	16	0	61	23	36	17	1	77	44	52	0	0	96	236
17:30	0	0	0	0	0	0	48	13	0	61	16	47	16	0	79	44	74	0	0	118	258
17:45	0	0	0	1	1	0	35	15	0	50	14	43	18	0	75	40	59	0	0	99	225
Total	0	0	0	3	3	0	176	56	0	232	69	165	74	1	309	167	257	0	0	424	968
18:00	0	0	0	0	0	0	41	20	1	62	15	49	20	0	84	38	60	0	0	98	244
18:15	0	0	0	0	0	0	50	8	0	58	17	47	17	0	81	24	45	0	0	69	208
18:30	0	0	0	1	1	0	41	17	0	58	17	41	14	1	73	50	53	0	0	103	235
18:45	0	0	0	0	0	0	40	23	0	63	19	30	20	0	69	28	37	0	0	65	197
Total	0	0	0	1	1	0	172	68	1	241	68	167	71	1	307	140	195	0	0	335	884
Grand Total	0	0	0	14	14	0	2052	953	5	3010	895	1938	650	7	3490	1846	2047	0	1	3894	10408
Apprch %	0	0	0	100		0	68.2	31.7	0.2		25.6	55.5	18.6	0.2		47.4	52.6	0	0		
Total %	0	0	0	0.1	0.1	0	19.7	9.2	0	28.9	8.6	18.6	6.2	0.1	33.5	17.7	19.7	0	0	37.4	
Vehicles	0	0	0	10	10	0	1999				1894					1811	1996				10171
% Vehicles	0	0	0	71.4	71.4	0	97.4	97.6	60	97.4	98.9	97.7	98.3	42.9	98	98.1	97.5	0	100	97.8	97.7
Trucks	0	0	0	4	4	0	53	23	2	78	10	44	11	4	69	35	51	0	0	86	237
% Trucks	0	0	0	28.6	28.6	0	2.6	2.4	40	2.6	1.1	2.3	1.7	57.1	2	1.9	2.5	0	0	2.2	2.3

# Short Elliott Hendrickson Inc.

3535 Vadnais Center Drive  
St. Paul, MN 55110

"Building a Better World for All of Us"



## TRAFFIC DATA

TH 52 & Thompson Ave E Ramp

Ref.Pt.: 127.633

Data By: Short Elliott Hendrickson, Inc.

TURN MOVEMENT COUNT

File Name : TH 52 & Thompson Ave E Ramp 2019

Site Code : 5b

Start Date : 5/2/2019

Page No : 3

Start Time	Southbound					Westbound					Northbound					Eastbound					Int. Total
	Left	Thru	Right	Peds	App. Total	Left	Thru	Right	Peds	App. Total	Left	Thru	Right	Peds	App. Total	Left	Thru	Right	Peds	App. Total	
Peak Hour Analysis From 06:00 to 08:45 - Peak 1 of 1																					
Peak Hour for Entire Intersection Begins at 07:00																					
07:00	0	0	0	0	0	0	49	40	0	89	24	28	10	0	62	28	26	0	0	54	205
07:15	0	0	0	0	0	0	70	42	0	112	25	34	17	0	76	17	29	0	0	46	234
07:30	0	0	0	0	0	0	68	35	0	103	31	32	8	2	73	25	40	0	0	65	241
07:45	0	0	0	0	0	0	62	28	0	90	29	24	9	0	62	28	30	0	0	58	210
Total Volume	0	0	0	0	0	0	249	145	0	394	109	118	44	2	273	98	125	0	0	223	890
% App. Total	0	0	0	0	0	0	63.2	36.8	0		39.9	43.2	16.1	0.7		43.9	56.1	0	0		
PHF	.000	.000	.000	.000	.000	.000	.889	.863	.000	.879	.879	.868	.647	.250	.898	.875	.781	.000	.000	.858	.923

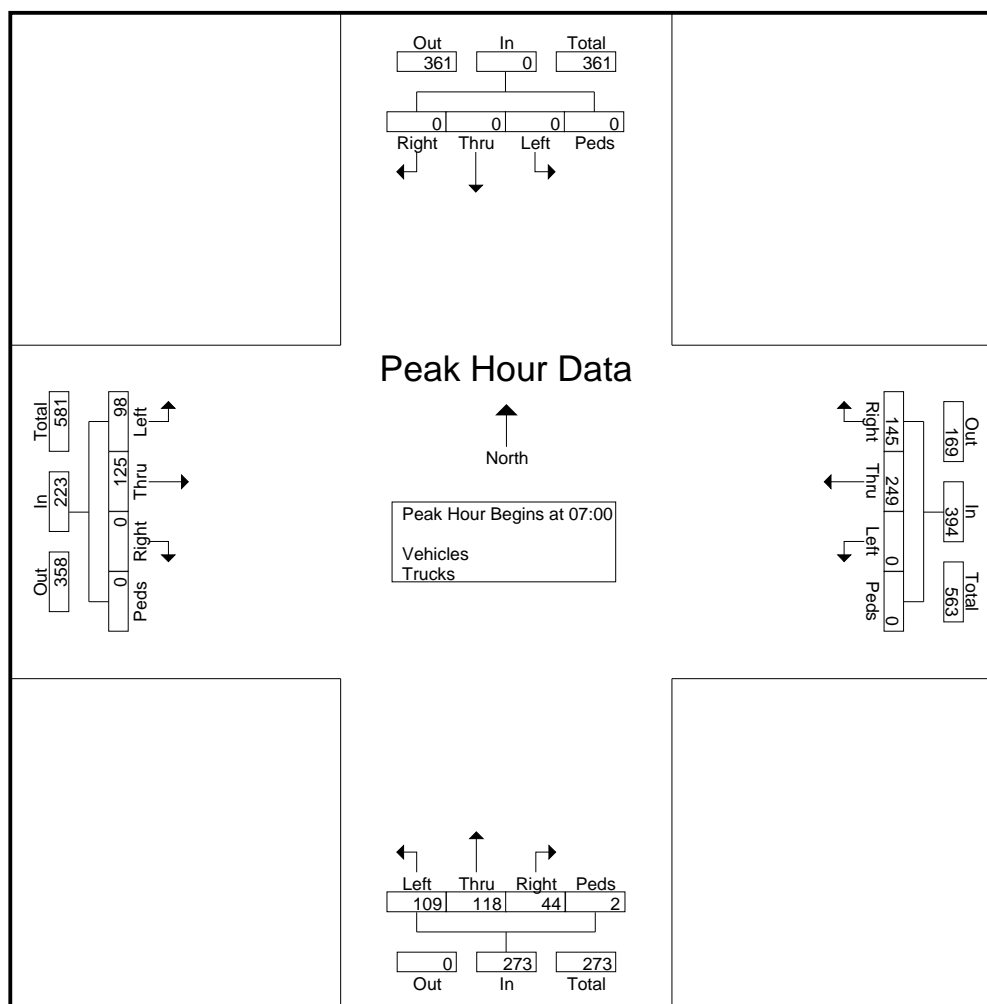

# Short Elliott Hendrickson Inc.

3535 Vadnais Center Drive  
St. Paul, MN 55110

"Building a Better World for All of Us"



## TRAFFIC DATA

TH 52 & Thompson Ave E Ramp

Ref.Pt.: 127.633

Data By: Short Elliott Hendrickson, Inc.

TURN MOVEMENT COUNT

File Name : TH 52 & Thompson Ave E Ramp 2019

Site Code : 5b

Start Date : 5/2/2019

Page No : 4

Start Time	Southbound					Westbound					Northbound					Eastbound					Int. Total
	Left	Thru	Right	Peds	App. Total	Left	Thru	Right	Peds	App. Total	Left	Thru	Right	Peds	App. Total	Left	Thru	Right	Peds	App. Total	
Peak Hour Analysis From 11:00 to 12:45 - Peak 1 of 1																					
Peak Hour for Entire Intersection Begins at 12:00																					
12:00	0	0	0	0	0	0	43	13	0	56	13	59	16	0	88	41	31	0	0	72	216
12:15	0	0	0	0	0	0	37	15	0	52	23	46	7	0	76	43	31	0	0	74	202
12:30	0	0	0	1	1	0	38	13	0	51	13	46	10	0	69	47	39	0	0	86	207
12:45	0	0	0	0	0	0	27	12	0	39	18	57	9	0	84	44	36	0	0	80	203
Total Volume	0	0	0	1	1	0	145	53	0	198	67	208	42	0	317	175	137	0	0	312	828
% App. Total	0	0	0	100		0	73.2	26.8	0		21.1	65.6	13.2	0		56.1	43.9	0	0		
PHF	.000	.000	.000	.250	.250	.000	.843	.883	.000	.884	.728	.881	.656	.000	.901	.931	.878	.000	.000	.907	.958

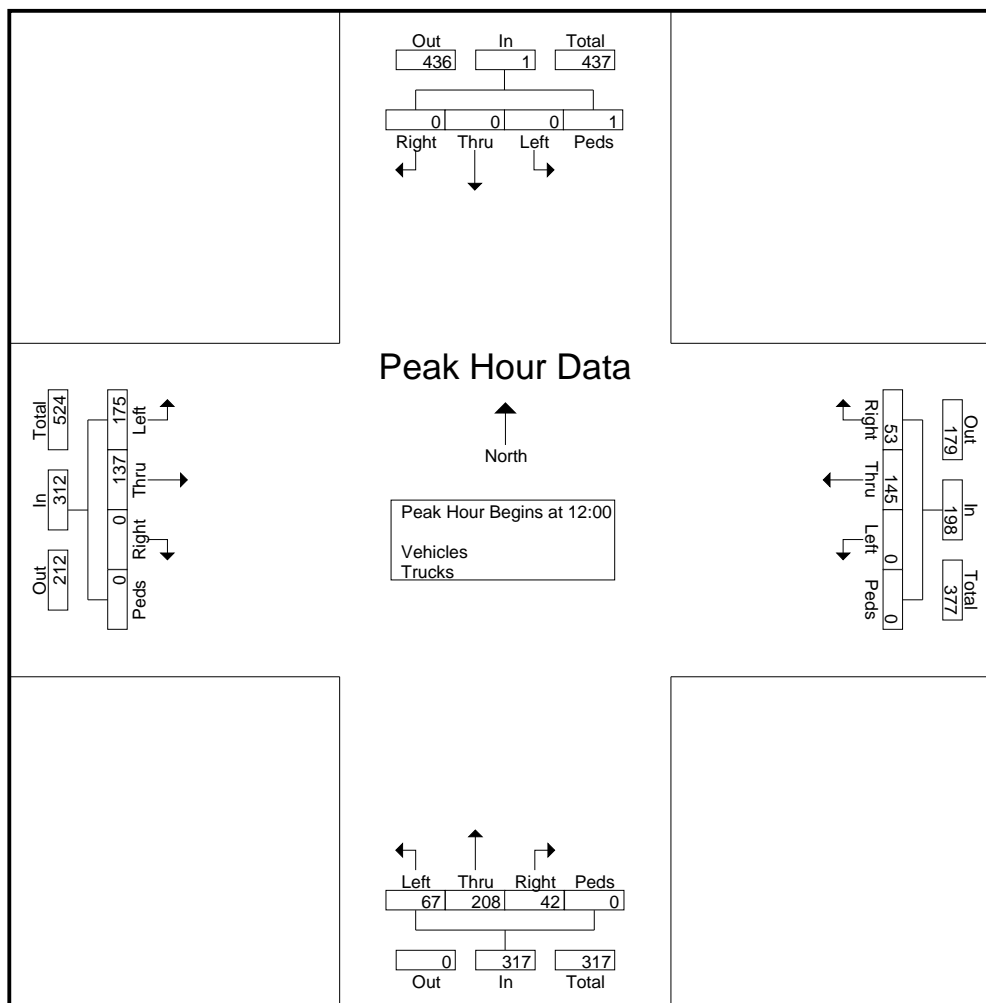

# Short Elliott Hendrickson Inc.

3535 Vadnais Center Drive  
St. Paul, MN 55110

"Building a Better World for All of Us"



## TRAFFIC DATA

TH 52 & Thompson Ave E Ramp

Ref.Pt.: 127.633

Data By: Short Elliott Hendrickson, Inc.

TURN MOVEMENT COUNT

File Name : TH 52 & Thompson Ave E Ramp 2019

Site Code : 5b

Start Date : 5/2/2019

Page No : 5

Start Time	Southbound					Westbound					Northbound					Eastbound					Int. Total
	Left	Thru	Right	Peds	App. Total	Left	Thru	Right	Peds	App. Total	Left	Thru	Right	Peds	App. Total	Left	Thru	Right	Peds	App. Total	
Peak Hour Analysis From 15:00 to 17:45 - Peak 1 of 1																					
Peak Hour for Entire Intersection Begins at 16:15																					
16:15	0	0	0	0	0	0	45	11	0	56	18	37	21	0	76	35	86	0	0	121	253
16:30	0	0	0	0	0	0	48	15	0	63	13	51	25	0	89	53	63	0	0	116	268
16:45	0	0	0	2	2	0	52	20	0	72	16	43	23	0	82	41	61	0	0	102	258
17:00	0	0	0	0	0	0	48	12	0	60	16	39	23	0	78	39	72	0	0	111	249
Total Volume	0	0	0	2	2	0	193	58	0	251	63	170	92	0	325	168	282	0	0	450	1028
% App. Total	0	0	0	100		0	76.9	23.1	0		19.4	52.3	28.3	0		37.3	62.7	0	0		
PHF	.000	.000	.000	.250	.250	.000	.928	.725	.000	.872	.875	.833	.920	.000	.913	.792	.820	.000	.000	.930	.959

