

MN Dept of Transportation

TRAFFIC DATA COLLECTION - Metro

TH-61 at 8th Ave S, FOREST LAKE
 Ref.Pt.: 160.390
 video RE / AL
 TURN MOVEMENT COUNT

File Name : TH-61 at 8th Ave S 2016
 Site Code :
 Start Date : 1/5/2016
 Page No : 1

Groups Printed- Cars +

Start Time	TH-61 SB Southbound				8th Ave South WB Westbound				TH-61 NB Northbound				8th Ave South EB Eastbound				Int. Total	
	Left	Thru	Right	Peds	Left	Thru	Right	Peds	Left	Thru	Right	Peds	Left	Thru	Right	Peds		
06:00	1	37	1	0	4	0	1	0	2	20	0	0	0	0	0	0	0	66
06:15	0	61	0	0	6	0	4	0	0	30	0	0	0	0	0	0	0	101
06:30	1	70	0	0	3	0	2	0	0	36	0	0	0	0	1	0	0	113
06:45	1	80	2	0	0	0	3	0	4	52	1	0	0	0	1	0	0	144
Total	3	248	3	0	13	0	10	0	6	138	1	0	0	0	2	0	0	424
07:00	3	108	0	0	6	2	4	0	0	44	0	0	1	0	0	0	0	168
07:15	2	173	0	0	0	2	4	0	0	64	0	0	0	1	0	0	0	246
07:30	11	177	4	0	4	7	19	0	0	87	0	0	2	0	1	0	0	312
07:45	10	171	3	0	12	16	43	0	6	134	1	0	3	0	2	0	0	401
Total	26	629	7	0	22	27	70	0	6	329	1	0	6	1	3	0	0	1127
08:00	5	80	5	0	2	4	14	0	3	89	0	0	2	3	2	0	0	209
08:15	5	81	1	0	5	1	4	0	4	61	1	0	1	0	1	0	0	165
08:30	4	65	2	0	2	0	3	0	4	79	0	0	0	0	1	0	0	160
08:45	3	87	3	0	0	6	8	0	7	91	5	0	3	0	0	0	0	213
Total	17	313	11	0	9	11	29	0	18	320	6	0	6	3	4	0	0	747
***** BREAK *****																		
15:00	9	80	6	0	4	2	14	0	10	123	0	3	10	15	3	0	0	279
15:15	9	121	11	0	4	11	8	0	18	121	6	0	10	6	5	0	0	330
15:30	8	147	8	1	5	31	9	0	8	91	1	0	7	3	6	0	0	325
15:45	15	142	15	0	2	4	8	0	16	127	2	0	7	6	11	0	0	355
Total	41	490	40	1	15	48	39	0	52	462	9	3	34	30	25	0	0	1289
16:00	10	124	8	0	3	6	6	0	13	153	9	0	12	6	6	0	0	356
16:15	7	152	10	0	4	6	10	0	12	203	3	0	11	8	7	0	0	433
16:30	7	148	6	1	2	19	13	0	22	125	3	1	21	16	8	0	0	392
16:45	7	178	7	0	9	6	8	0	16	165	3	3	7	5	8	0	0	422
Total	31	602	31	1	18	37	37	0	63	646	18	4	51	35	29	0	0	1603
17:00	10	138	12	0	5	4	9	0	10	130	6	0	8	8	9	0	0	349
17:15	8	168	8	0	2	4	5	0	13	185	2	0	11	6	7	0	0	419
17:30	6	112	10	0	6	17	12	0	11	101	2	0	6	4	4	0	0	291
17:45	5	90	9	0	2	8	7	0	15	128	3	0	6	11	8	0	0	292
Total	29	508	39	0	15	33	33	0	49	544	13	0	31	29	28	0	0	1351
Grand Total	147	2790	131	2	92	156	218	0	194	2439	48	7	128	98	91	0	0	6541
Apprch %	4.8	90.9	4.3	0.1	19.7	33.5	46.8	0	7.2	90.7	1.8	0.3	40.4	30.9	28.7	0	0	
Total %	2.2	42.7	2	0	1.4	2.4	3.3	0	3	37.3	0.7	0.1	2	1.5	1.4	0	0	

MN Dept of Transportation

TRAFFIC DATA COLLECTION - Metro

TH-61 at 8th Ave S, FOREST LAKE
 Ref.Pt.: 160.390
 video RE / AL
 TURN MOVEMENT COUNT

File Name : TH-61 at 8th Ave S 2016
 Site Code :
 Start Date : 1/5/2016
 Page No : 2

Start Time	TH-61 SB Southbound					8th Ave South WB Westbound					TH-61 NB Northbound					8th Ave South EB Eastbound					Int. Total
	Left	Thru	Right	Peds	App. Total	Left	Thru	Right	Peds	App. Total	Left	Thru	Right	Peds	App. Total	Left	Thru	Right	Peds	App. Total	
Peak Hour Analysis From 06:00 to 08:45 - Peak 1 of 1																					
Peak Hour for Entire Intersection Begins at 07:15																					
07:15	2	173	0	0	175	0	2	4	0	6	0	64	0	0	64	0	1	0	0	1	246
07:30	11	177	4	0	192	4	7	19	0	30	0	87	0	0	87	2	0	1	0	3	312
07:45	10	171	3	0	184	12	16	43	0	71	6	134	1	0	141	3	0	2	0	5	401
08:00	5	80	5	0	90	2	4	14	0	20	3	89	0	0	92	2	3	2	0	7	209
Total Volume	28	601	12	0	641	18	29	80	0	127	9	374	1	0	384	7	4	5	0	16	1168
% App. Total	4.4	93.8	1.9	0		14.2	22.8	63	0		2.3	97.4	0.3	0		43.8	25	31.2	0		
PHF	.636	.849	.600	.000	.835	.375	.453	.465	.000	.447	.375	.698	.250	.000	.681	.583	.333	.625	.000	.571	.728

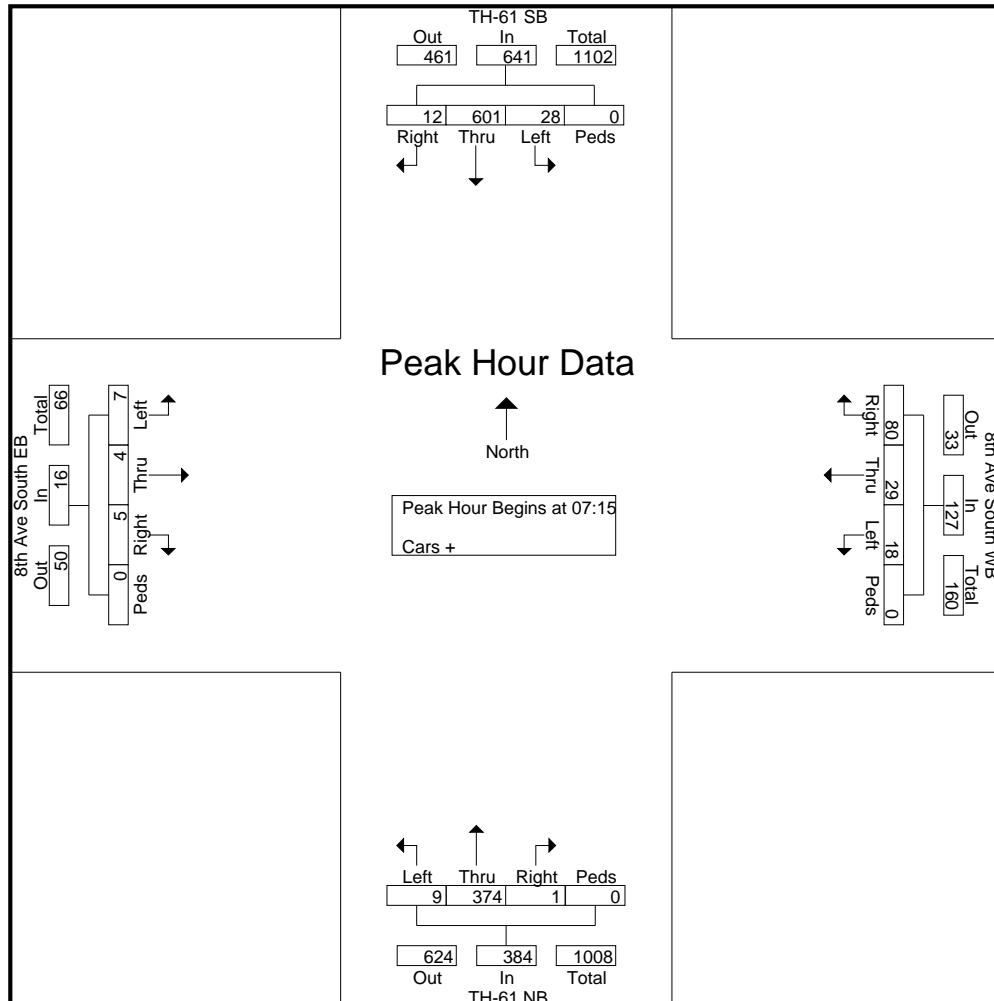

MN Dept of Transportation

TRAFFIC DATA COLLECTION - Metro

TH-61 at 8th Ave S, FOREST LAKE
 Ref.Pt.: 160.390
 video RE / AL
 TURN MOVEMENT COUNT

File Name : TH-61 at 8th Ave S 2016
 Site Code :
 Start Date : 1/5/2016
 Page No : 3

Start Time	TH-61 SB Southbound					8th Ave South WB Westbound					TH-61 NB Northbound					8th Ave South EB Eastbound					Int. Total
	Left	Thru	Right	Peds	App. Total	Left	Thru	Right	Peds	App. Total	Left	Thru	Right	Peds	App. Total	Left	Thru	Right	Peds	App. Total	
Peak Hour Analysis From 15:00 to 17:45 - Peak 1 of 1																					
Peak Hour for Entire Intersection Begins at 16:00																					
16:00	10	124	8	0	142	3	6	6	0	15	13	153	9	0	175	12	6	6	0	24	356
16:15	7	152	10	0	169	4	6	10	0	20	12	203	3	0	218	11	8	7	0	26	433
16:30	7	148	6	1	162	2	19	13	0	34	22	125	3	1	151	21	16	8	0	45	392
16:45	7	178	7	0	192	9	6	8	0	23	16	165	3	3	187	7	5	8	0	20	422
Total Volume	31	602	31	1	665	18	37	37	0	92	63	646	18	4	731	51	35	29	0	115	1603
% App. Total	4.7	90.5	4.7	0.2		19.6	40.2	40.2	0		8.6	88.4	2.5	0.5		44.3	30.4	25.2	0		
PHF	.775	.846	.775	.250	.866	.500	.487	.712	.000	.676	.716	.796	.500	.333	.838	.607	.547	.906	.000	.639	.926

